

KIT FEATURES

- ▶ DIN head unit provisions
- ▶ DIN head unit supports

KIT COMPONENTS

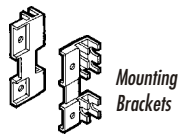
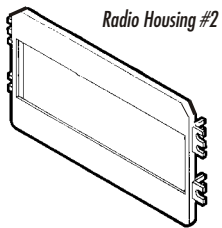
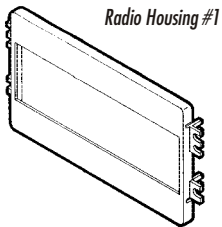

TOOLS REQUIRED



99-1003

INSTALLATION INSTRUCTIONS

APPLICATIONS

CAR	PAGE
KIA	
Sephia 1995-97.....	1
Sephia 1998-01.....	1
Spectra 2000.....	1
Sportage 1995-97.....	2
Sportage 1998-02.....	2



KIA Sephia 1995-97

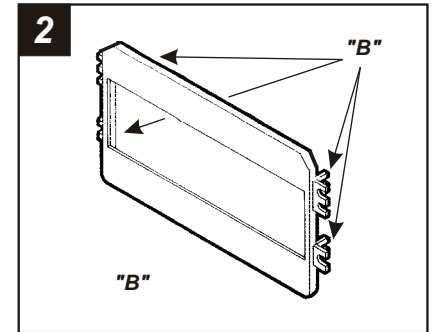
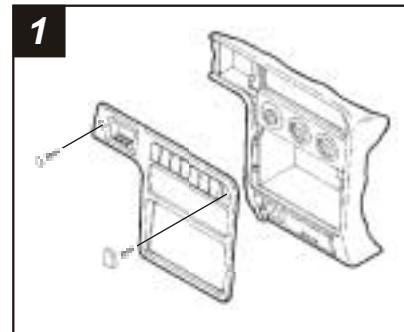

Disconnect the negative battery terminal to prevent an accidental short circuit. Pop off the plastic screw cover located to the left of the coin tray and remove (1) Phillips screw exposed. Using a small flat-blade screwdriver, pop out the dummy switch located in the far right position of the switch panel and remove (1) Phillips screw exposed. Unclip the dash trim bezel and remove. Remove (4) Phillips screws securing the factory head unit and disconnect the wiring.

Cut and remove mounting tabs "B" from **Radio Housing #2**. (The tabs can be identified by the stamped letter on the back of each tab). Skip to the Installation Instructions for ALL VEHICLES on Page #3.

KIA Sephia 1998-01 / Spectra 2000

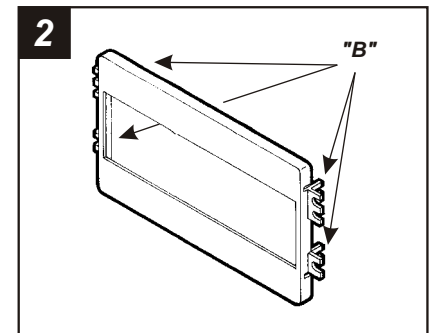
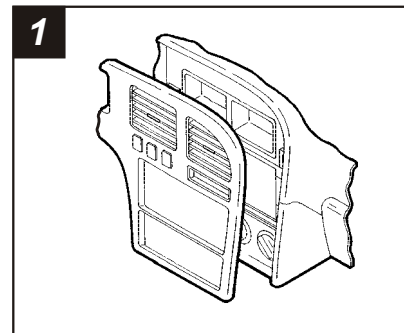

Disconnect the negative battery terminal to prevent an accidental short circuit. Remove (2) Phillips screws above the instrument cluster. Unclip the entire dash trim bezel and remove. Remove (4) screws securing the factory head unit and disconnect the wiring.

Cut and remove mounting tabs "B" from **Radio Housing #1**. (The tabs can be identified by the stamped letter on the back of each tab). Skip to the Installation Instructions for ALL VEHICLES on Page #3.

KIA Sportage 1995-97

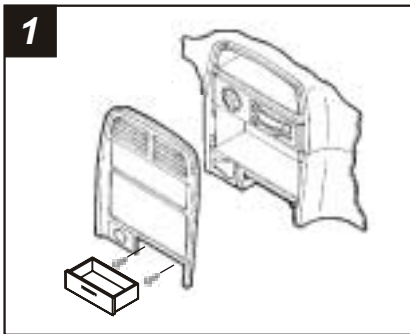

Disconnect the negative battery terminal to prevent an accidental short circuit. Remove the ashtray and (2) Phillips screws exposed in the ashtray cavity. Unclip the dash trim bezel and remove. Remove (4) Phillips screws securing the factory head unit and disconnect the wiring.

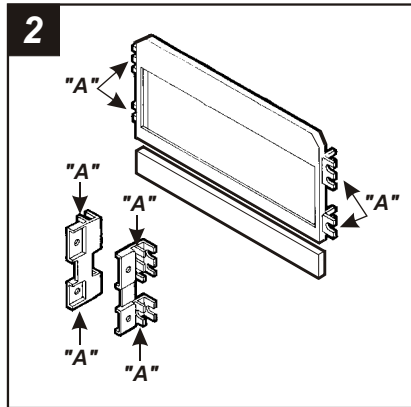

Cut and remove mounting tabs "A" from the **Mounting Brackets** and **Radio Housing #2**. (The tabs can be identified by the stamped letter on the back of each tab). Locate the scored line on the back of the Radio Housing and break away the bottom portion of the Housing as shown. Skip to the *Installation Instructions for ALL VEHICLES* on Page #3.

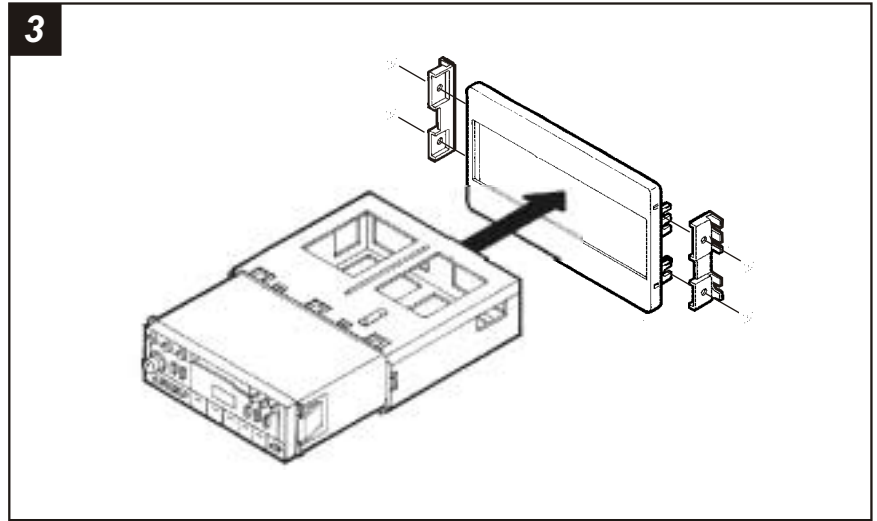

SEPHIA, SPECTRA: Slide the DIN cage into the **Radio Housing** and secure by bending the metal locking tabs down. Slide the aftermarket head unit into the cage until secure.
SPORTAGE: Secure the **Mounting Brackets** to the **Radio Housing** with (4) **Captive Studs** and (4) **Pal Nuts** supplied. Slide the DIN cage into the **Radio Housing** and secure by bending the metal locking tabs down. Slide the aftermarket head unit into the cage until secure.

KIA Sportage 1998-02

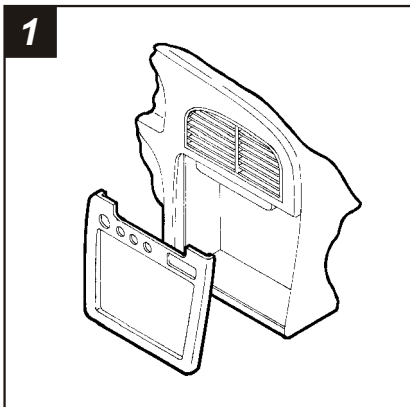

Disconnect the negative battery terminal to prevent an accidental short circuit. Unclip the radio trim bezel and remove. Remove (4) Phillips screws securing the factory head unit and disconnect the wiring.

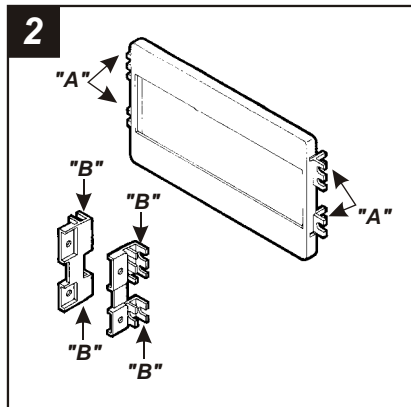

Cut and remove mounting tabs "A" from **Radio Housing #1**. Locate the v-cut on the back of each **Mounting Bracket**, cut along the v-cut and remove the back portion of each Bracket ("B"). (The tabs can be identified by the stamped letter on the back of each tab). Skip to the *Installation Instructions for ALL VEHICLES* on Page #3.

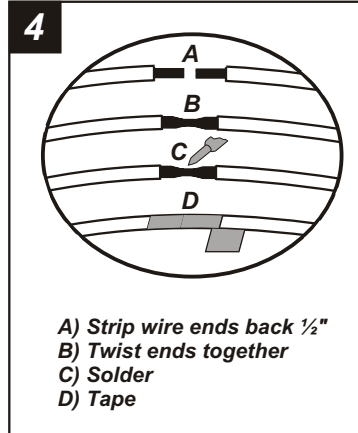

Locate the factory wiring harness in the dash. Metra recommends using the proper mating adaptor and making connections as shown. (Isolate and individually tape off the ends of any unused wires to prevent electrical short circuit).

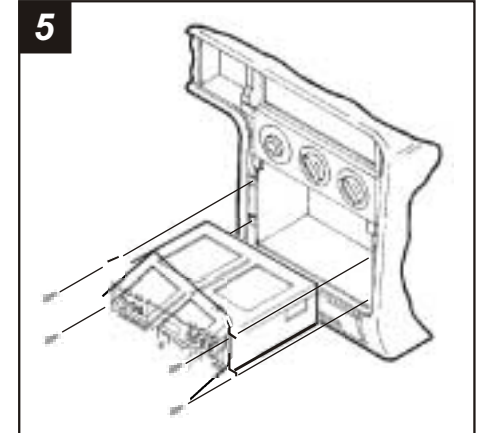

Re-connect the battery terminal and test the unit for proper operation. Mount the head unit/kit assembly to the sub-dash with (4) Phillips screws previously removed in step #1.