

## KIT FEATURES

- ▶ Shaft and DIN unit provisions

## KIT COMPONENTS

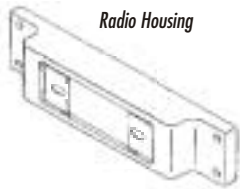

## TOOLS REQUIRED



# 99-2020 INSTALLATION INSTRUCTIONS

## APPLICATIONS

<b>CAR</b>	<b>PAGE</b>
<b>BUICK</b>	
Regal 1988-92.....	1-2



## ALL VEHICLES

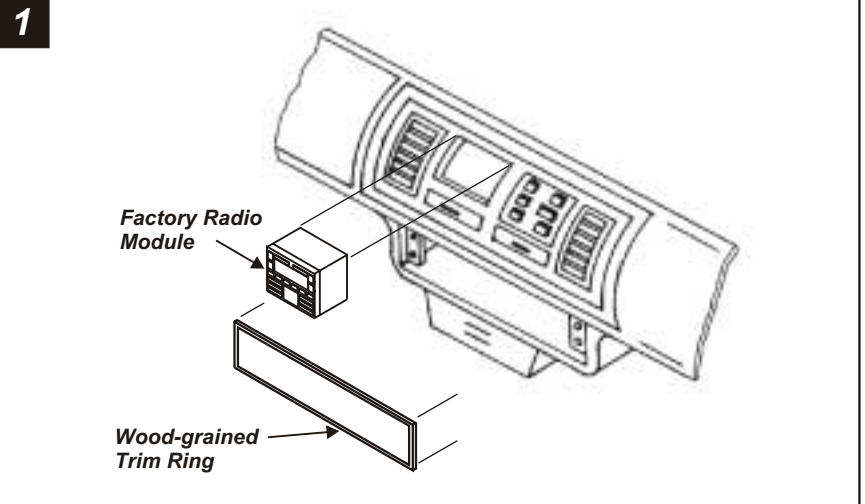

Disconnect the negative battery terminal to prevent an accidental short circuit. Unclip the entire dash trim bezel and remove. Remove (2) 9/32" fasteners from the right side of the factory radio module and (2) fasteners from the left side. Disconnect the wiring and remove the module. (Metra's **88-00-2020 Radio Replacement Pocket** can be ordered to fill the space). Unclip the wood-grained trim ring from the factory cassette location. Remove (4) 7/32" screws securing the cassette assembly and disconnect the wiring.

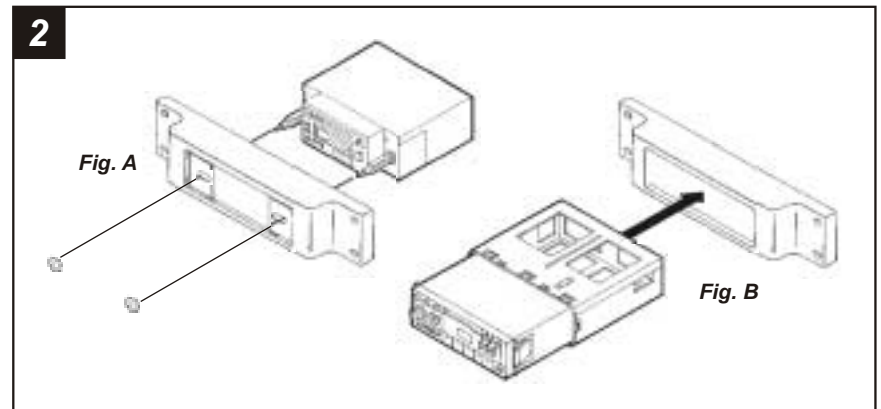

**2-SHAFT HEAD UNITS:** Slide the aftermarket head unit into the kit and secure with shaft nuts. (see Fig. A)

**DIN HEAD UNITS:** Cut and remove the shaft supports from the **Radio Housing**. Slide the DIN cage into the kit and secure by bending the metal locking tabs down. Slide the aftermarket head unit into the cage until secure. (see Fig. B)

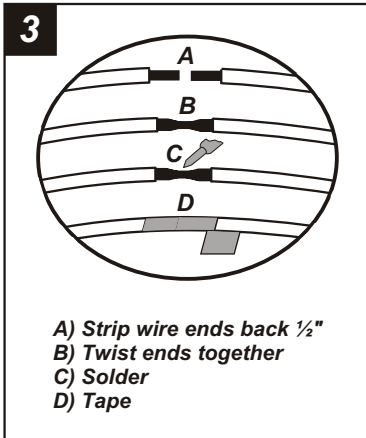

Locate the factory wiring harness in the dash. Metra recommends using the proper mating adaptor and making connections as shown. (Isolate and individually tape off the ends of any unused wires to prevent electrical short circuit).

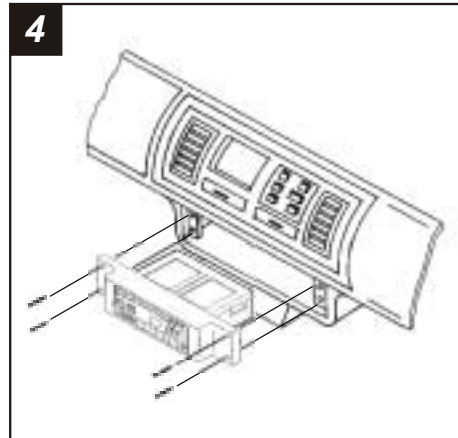

Re-connect the battery terminal and test the unit for proper operation. Mount the head unit/kit assembly to the sub-dash with **(4) Phillips Pan-head Screws** supplied.

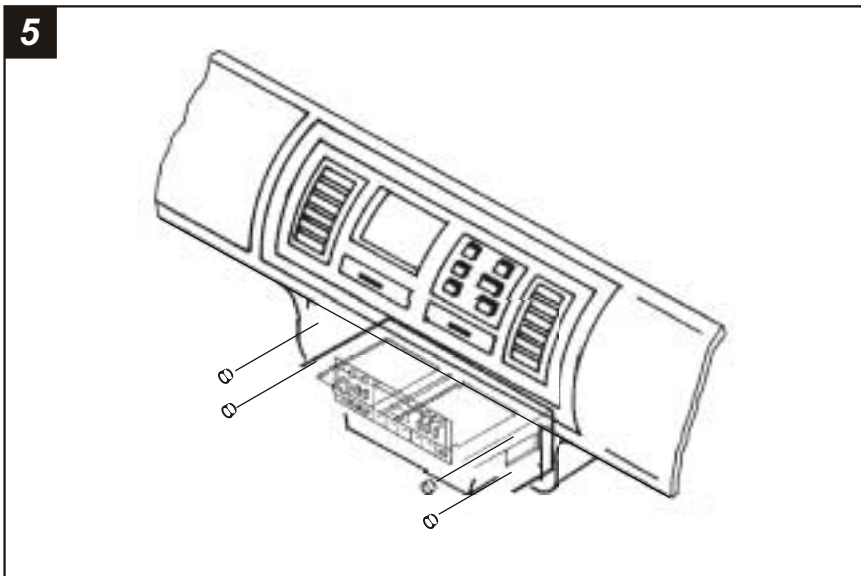

Insert the **(4) Rubber Plugs** into the **Radio Housing** over the mounted screw heads.