

KIT FEATURES

- ▶ Shaft and DIN unit provisions

KIT COMPONENTS

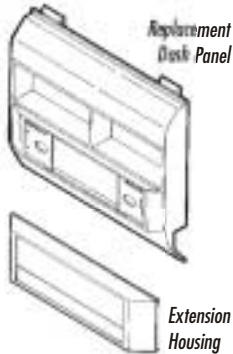

(2) #10 Phillips Pan-head Screws

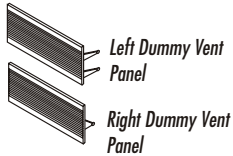

TOOLS REQUIRED

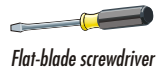

Flat-blade screwdriver



Cutting tool



Drill



99-3000 AW-333GM DW-3000 INSTALLATION INSTRUCTIONS

APPLICATIONS

<u>CAR</u>	<u>PAGE</u>
CHEVROLET	
Blazer 1992-94.....	1-3
Pickup 1988-94.....	1-3
Suburban 1992-94.....	1-3
GMC	
C-Series 1988-94.....	1-3
Suburban 1992-94.....	1-3
Yukon 1992-94.....	1-3

ALL VEHICLES

1

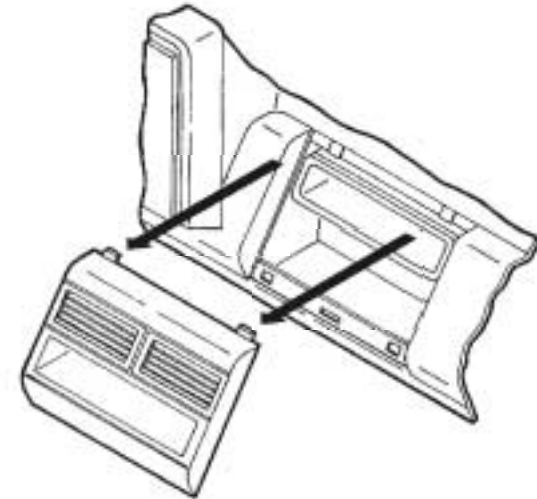

Disconnect the negative battery terminal to prevent an accidental short circuit. Pull out on the bottom of the radio trim bezel. Unhook the top corners of the bezel and remove.

2

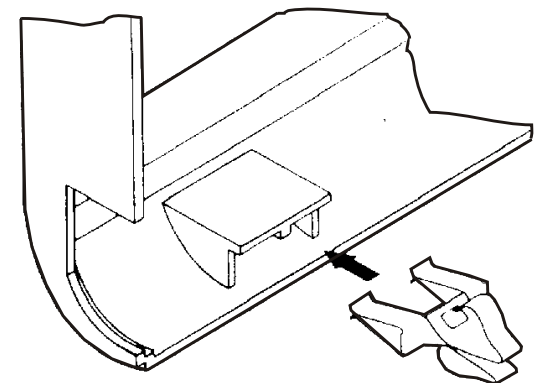

Remove the metal fastening clips from the bottom of the factory dash panel and attach them to the same location on the **Replacement Dash Panel**.

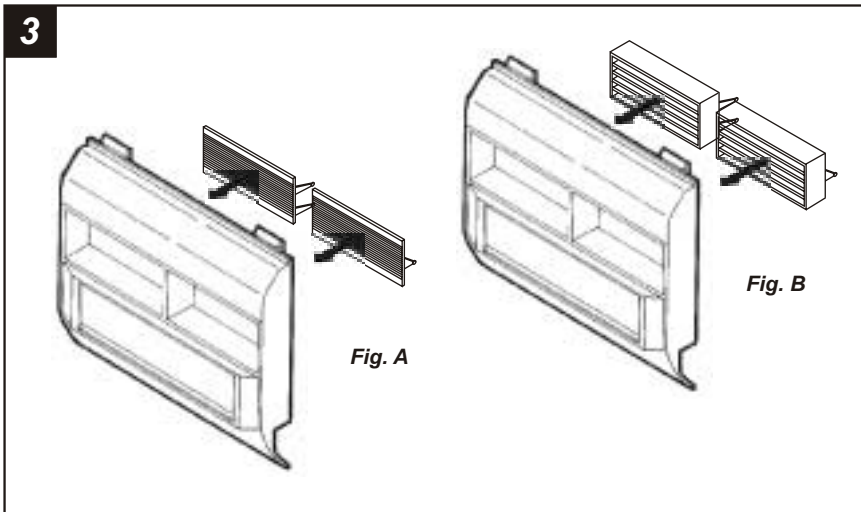

MODELS NOT EQUIPPED WITH A/C: Snap the **Dummy Vent Panels** into the **Replacement Dash Panel**. (see Fig. A). Be sure the **Left Dummy Vent Panel** goes into the left opening and the **Right Dummy Vent Panel** goes into the right opening.

MODELS EQUIPPED WITH A/C: Remove the a/c vents from the factory dash panel by releasing the spring fastening clips securing them to the panel. Mount the vents to the **Replacement Dash Panel** by inserting the inner edge of the vent into the center inside pivot hole and the outer edge of the vent into the outer pivot hole. Using the same metal spring clips and mounting procedures from the original truck panel to mount the vents to the Replacement Dash Panel. (see Fig. B).

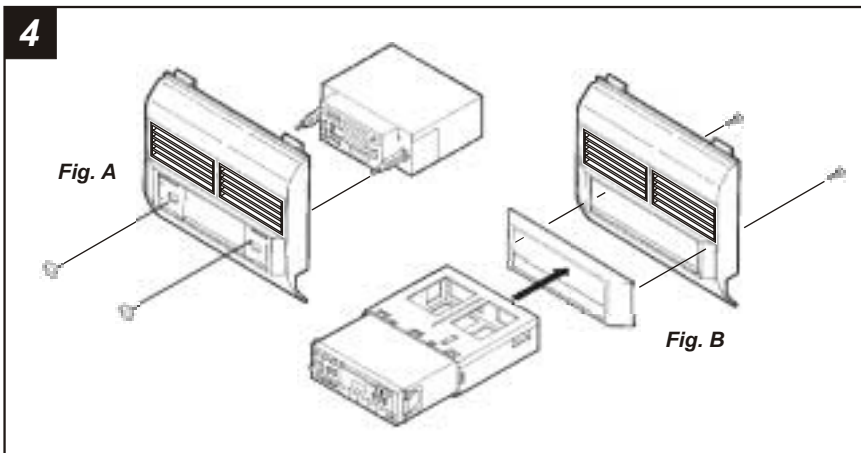

SHAFT HEAD UNITS: Slide the head unit into the kit and secure with shaft nuts. (see Fig. A)

DIN HEAD UNITS: Cut and remove the shaft supports from the **Replacement Dash Panel**. Locate the dimple on either side of the radio opening on the back of the Replacement Dash Panel. Drill (2) **3/16"** holes through the dimples. Mount the **Extension Plate** to the front of the Replacement Dash Panel (through the drilled holes) with (2) **#10 Phillips Pan-head Screws** supplied. Slide the DIN cage into the kit and secure by bending the metal locking tabs down. Slide the aftermarket head unit into the cage until secure. (see Fig. B)

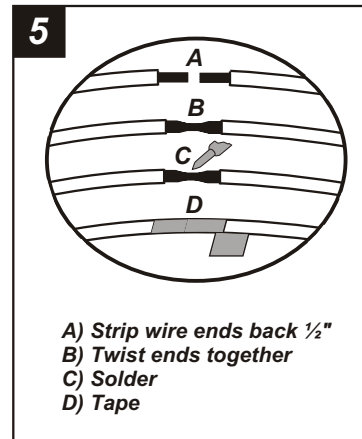

Locate the factory wiring harness in the dash. Metra recommends using the proper mating adaptor and making connections as shown. (Isolate and individually tape off the ends of any unused wires to prevent electrical short circuit).

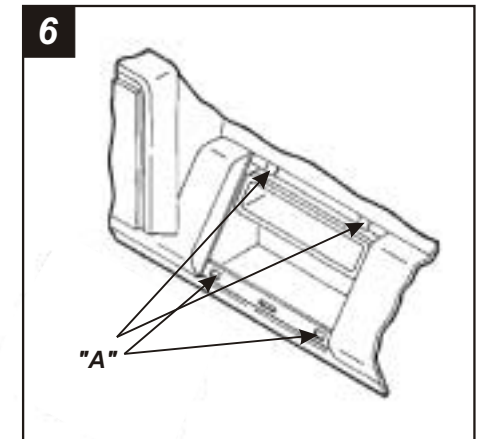

Locate the (4) mounting positions in the sub-dash ("A").

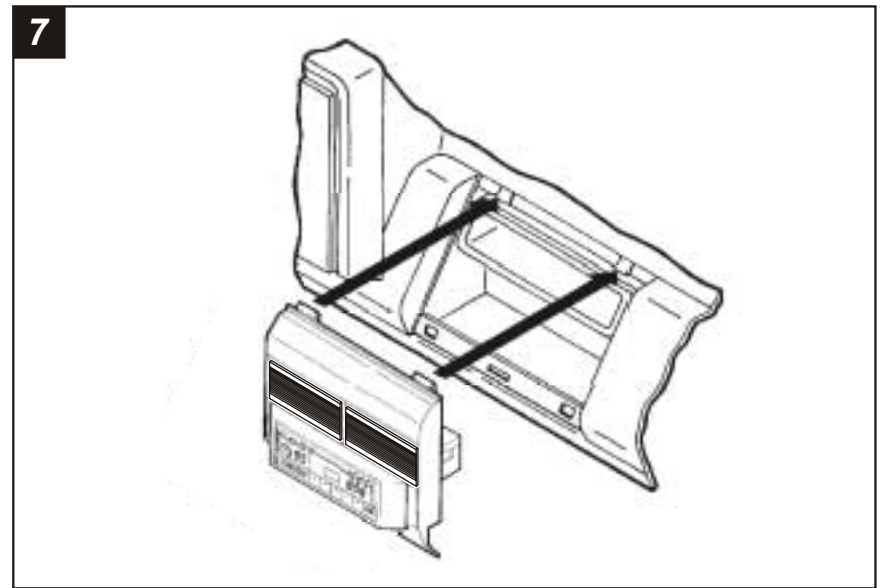

Re-connect the battery terminal and test the unit for proper operation. Snap the head unit/Replacement Panel assembly into the sub-dash.