

**KIT FEATURES**

- ▶ Shaft and DIN unit provisions
- ▶ Equalizer provisions

**KIT COMPONENTS**

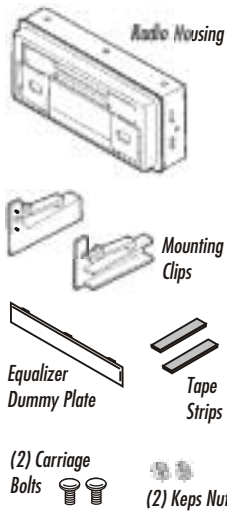

**TOOLS REQUIRED**

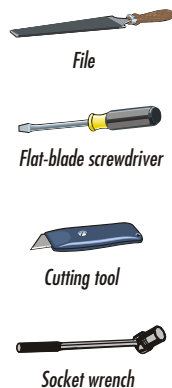

# 99-3003 INSTALLATION INSTRUCTIONS

**APPLICATIONS**

<b>CAR</b>	<b>PAGE</b>
<b>CADILLAC</b>	
Escalade 1999-00.....	1
<b>CHEVROLET</b>	
Astro 1996-00.....	2
Express (full size van) 1996-00.....	1
Pickup 1995-00.....	1
Silverado 1999-00.....	2
Suburban 1995-00.....	1
Tahoe 1995-00.....	1
<b>GMC</b>	
Safari 1996-00.....	2
Sierra 1995-00.....	1
Suburban 1995-00.....	1
Savana (full size van) 1996-00.....	1
Yukon 1995-00.....	1

**CHEVROLET Astro / GMC Safari 1996-00**



Disconnect the negative battery terminal to prevent an accidental short circuit. Place the gear selector in its lowest position. Unclip the perimeter of the dash trim bezel. Disconnect the rear a/c control harness and the headlight switch from the back of the dash trim bezel. Using a flat-blade screwdriver, press down on the outside clips of the factory head unit and remove.

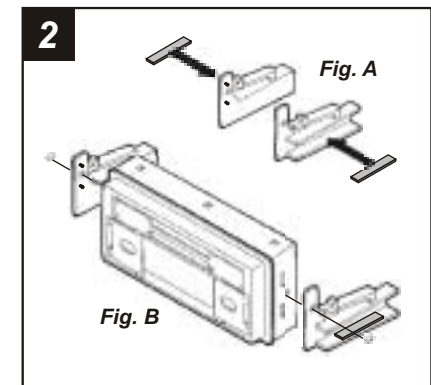

Peel away the paper backings from the **Tape Strips** and stick the Strips to the lower shelves of the **Mounting Clips**. (see Fig. A). Secure the **Mounting Clips** to the sides of the **Radio Housing** with **(2) Carriage Bolts** and **(2) Keps Nuts** supplied. (see Fig. B). Skip to the Installation Instructions for ALL VEHICLES on Page #2.

**CHEVROLET Express / GMC Savana 1996-00**

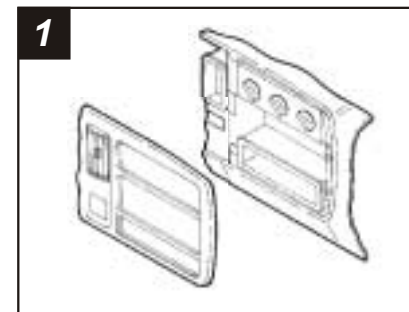

Disconnect the negative battery terminal to prevent an accidental short circuit. Unclip the plastic trim piece located below the steering column. Unclip the dash trim bezel. Pull the bezel over the steering column and disconnect the wiring. Using a flat-blade screwdriver, press down on the outside clips of the factory head unit and remove.

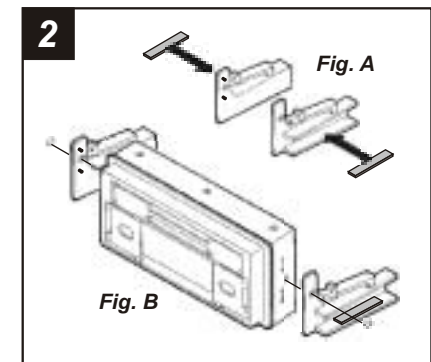

Peel away the paper backings from the **Tape Strips** and stick the Strips to the lower shelves of the **Mounting Clips**. (see Fig. A). Secure the **Mounting Clips** to the sides of the **Radio Housing** with **(2) Carriage Bolts** and **(2) Keps Nuts** supplied. (see Fig. B). Skip to the Installation Instructions for ALL VEHICLES on Page #2.

**CADILLAC Escalade 1999-00**  
**CHEVROLET Pickup/Suburban/Tahoe 1995-00 • Silverado 1999-00**  
**GMC Sierra/Suburban/Yukon 1995-00**

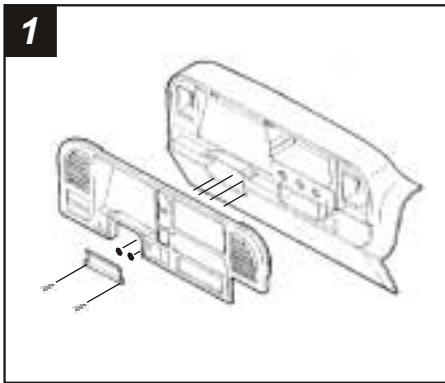

Disconnect the negative battery terminal to prevent an accidental short circuit. Remove the steering column filler panel and the ashtray. Unclip the dash trim bezel and remove. Using a small flat-blade screwdriver, press down on the outer clips of the factory head unit (or pocket). Disconnect the wiring and remove the unit.

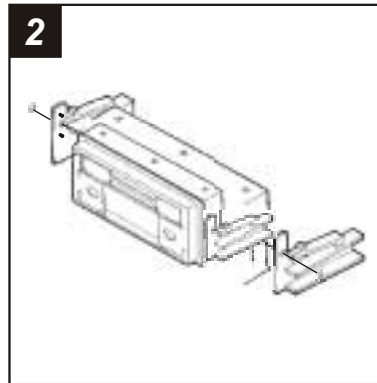

Secure the **Mounting Clips** to the sides of the **Radio Housing** with (2) **Carriage Bolts** and (2) **Keps Nuts** supplied. Skip to the **Installation Instructions for ALL VEHICLES** on Page #2.

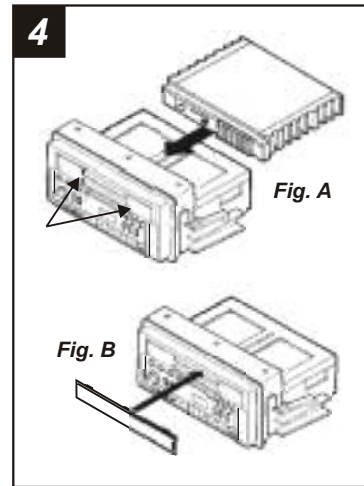

**IF AN EQUALIZER WILL BE INCLUDED:** Cut and remove the supports from the equalizer opening. Slide the aftermarket equalizer into the back of the **Radio Housing**. Using the hardware included with the equalizer, mount the unit to the kit. (see Fig. A)  
**IF AN EQUALIZER WILL NOT BE INCLUDED:** Snap the **Equalizer Dummy Plate** into the **Radio Housing**. (see Fig. B)

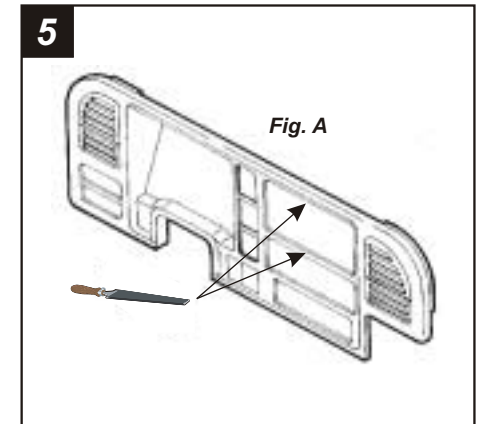

Using a file, remove **1/32"** from the top and bottom edges of the dash trim bezel radio opening. (see Fig. A). Insert the head unit/kit assembly into opening (through the back of the bezel) to insure proper clearance has been established.

**ALL VEHICLES**

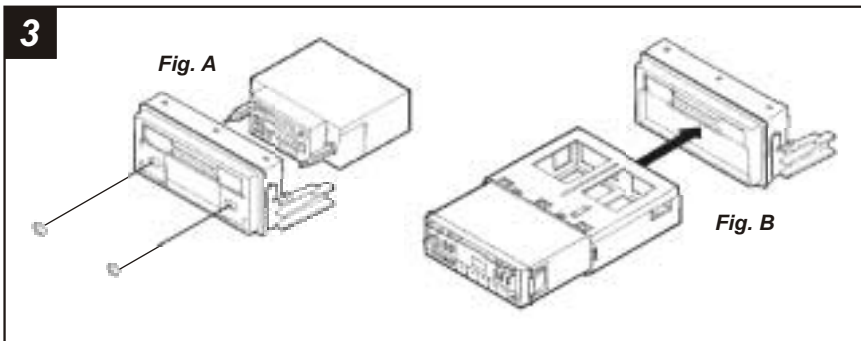

**2-SHAFT HEAD UNITS:** Slide the aftermarket head unit into the kit and secure with shaft nuts. (see Fig. A)

**DIN HEAD UNITS:** Cut and remove the shaft supports from the **Radio Housing**. Slide the DIN cage into the kit and secure by bending the metal locking tabs down. Slide the aftermarket head unit into the cage until secure. (see Fig. B)

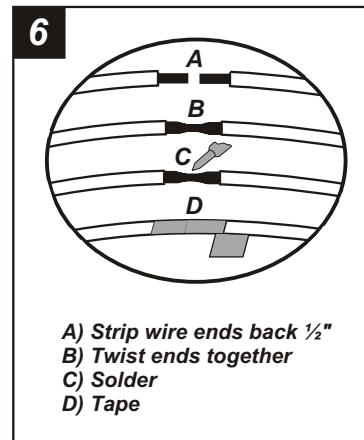

A) Strip wire ends back  $\frac{1}{2}$ "  
 B) Twist ends together  
 C) Solder  
 D) Tape

Locate the factory wiring harness in the dash. Metra recommends using the proper mating adaptor and making connections as shown. (Isolate and individually tape off the ends of any unused wires to prevent electrical short circuit).

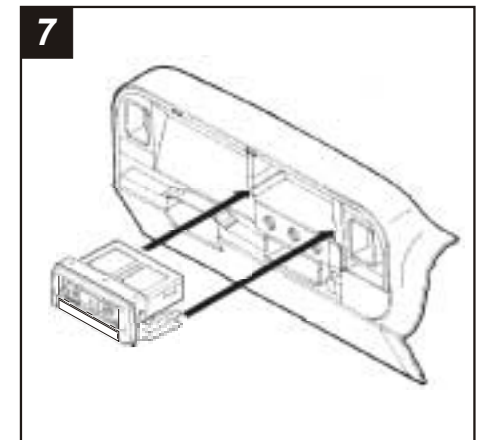

Re-connect the battery terminal and test the unit for proper operation. Slide the head unit/kit assembly into the sub-dash until the side clips engage.