

## KIT FEATURES

- ▶ Shaft and DIN unit provisions
- ▶ Various mounting depth alternatives

## KIT COMPONENTS

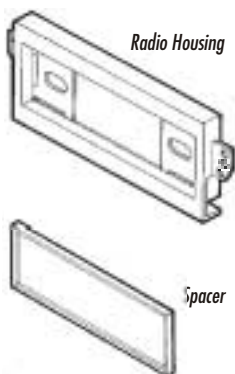

## TOOLS REQUIRED



Phillips screwdriver



Cutting tool



Socket wrench



# 99-3300 INSTALLATION INSTRUCTIONS

## APPLICATIONS

### CAR

#### CHEVROLET

	<u>PAGE</u>
Blazer 1998-00.....	1
Camaro 1997-99.....	1
Caprice 1994-96.....	1
Cavalier 1995-99.....	1
Corvette 1997-99.....	2
Impala SS 1995-96.....	1
Lumina 1995-99.....	2
Malibu 1997-99.....	2
Monte Carlo 1995-99.....	2
S-10 Pickup 1998-00.....	1
Venture 1997-99.....	2

#### GMC

Jimmy 1998-00.....	1
Sonoma Pickup 1998-00.....	1

#### OLDSMOBILE

Silhouette 1997-00.....	2
-------------------------	---

#### PONTIAC

Montana 1999.....	2
TransPort 1997-98.....	2

## CHEVROLET Blazer/S-10 Pickup 1998-00 • GMC Jimmy/Sonoma 1998-00

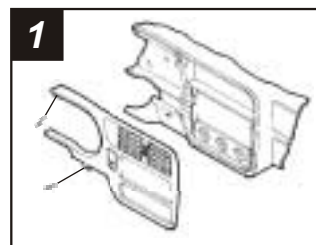

1 Disconnect the negative battery terminal to prevent an accidental short circuit. Remove (2) 9/32" hex-head screws from the knee bolster. Pull down on the bolster and remove 9/32" screws exposed on the base of the dash trim bezel. Remove (1) Phillips screw above the instrument cluster. Unclip the dash trim bezel and remove. Remove (2) 9/32" hex-head screws securing the factory head unit and disconnect the wiring. Skip to the Installation Instructions for ALL VEHICLES on Page #3.

## CHEVROLET Caprice / Impala SS 1995-96

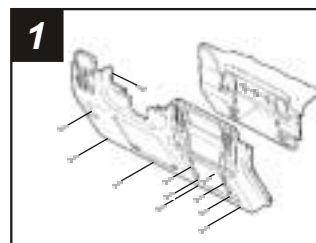

1 Disconnect the negative battery terminal to prevent an accidental short circuit. Remove (5) hex-head screws from the ashtray cavity. Remove (4) hex-head screws from the base of the dash trim bezel. Unsnap the fuse box cover and remove (1) hex-head screw exposed. Remove (2) hex-head screws above the instrument cluster. Place the gear selector in "D1". Pull out on the cluster trim and remove. Remove (1) hex-head screw exposed on the left edge of the dash trim bezel. Unclip the dash trim bezel (including the radio trim bezel) and remove. Skip to the Installation Instructions for ALL VEHICLES on Page #3.

## CHEVROLET Camaro 1997-99

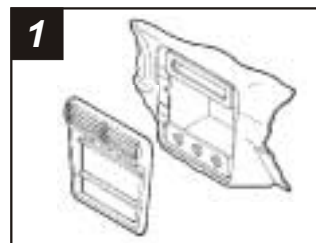

1 Disconnect the negative battery terminal to prevent an accidental short circuit. Unclip the radio trim bezel and remove. Remove (2) 7mm hex-head screws securing the factory head unit and disconnect the wiring. Skip to the Installation Instructions for ALL VEHICLES on Page #3.

## CHEVROLET Cavalier 1995-99

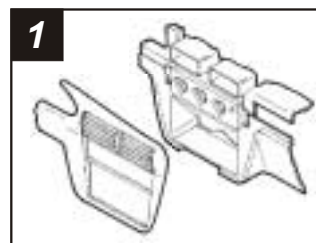

1 Disconnect the negative battery terminal to prevent an accidental short circuit. Remove (3) 7mm hex-head screws from the top of the glove box liner. Remove (2) 7mm hex-head screws from the top-left corner of the glove box cavity. Remove (1) Phillips screw from the defroster duct. Remove the duct work and (1) Phillips screw exposed. Unclip the dash trim piece and remove (2) Phillips screws exposed. Remove the dash pad and (3) Phillips screws exposed at the top of the radio trim bezel. Skip to the Installation Instructions for ALL VEHICLES on Page #3.

## CHEVROLET Corvette 1997-99

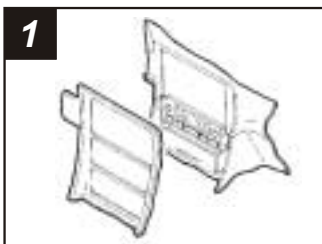

1 Disconnect the negative battery terminal to prevent an accidental short circuit. Pry out on the ride control switch and disconnect the wiring. Unsnap the switch trim and remove (2) 10mm hex-head bolts exposed. Open the center console door, remove (4) screws from the inner hinge and remove the door. Open the ashtray and remove (1) screw exposed. Remove the ashtray and (1) screw exposed. Unclip the small grille to the left of the ignition switch and remove (1) screw exposed. Unclip the base of the radio trim bezel and remove. Skip to the Installation Instructions for ALL VEHICLES on Page #3.

## CHEVROLET Lumina / Monte Carlo 1995-99

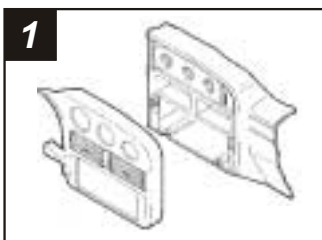

1 Disconnect the negative battery terminal to prevent an accidental short circuit. Unclip the dash trim bezel and remove. (It may be necessary to loosen the knee bolster). Remove (2) 7mm hex-head screws securing the factory head unit and disconnect the wiring. Skip to the Installation Instructions for ALL VEHICLES on Page #3.

## CHEVROLET Malibu 1997-99

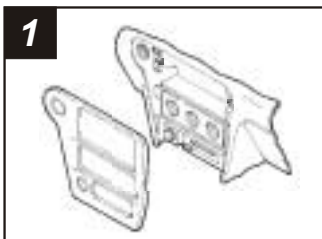

1 Disconnect the negative battery terminal to prevent an accidental short circuit. Unclip the radio trim bezel and remove. Remove (2) 9/32" hex-head screws securing the factory head unit and disconnect the wiring. Skip to the Installation Instructions for ALL VEHICLES on Page #3.

## CHEVROLET Venture 1997-99 / OLDSMOBILE Silhouette 1997-00 PONTIAC Montana 1999 / TransSport 1997-98

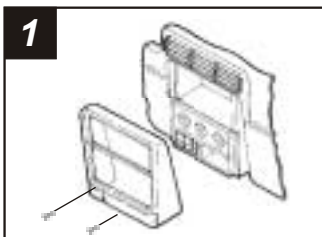

1 Disconnect the negative battery terminal to prevent an accidental short circuit. Remove the ashtray and (1) Phillips screw exposed in the ashtray cavity. Remove (1) Phillips screw from the cigarette lighter compartment. Remove (2) Phillips screws securing the factory head unit and disconnect the wiring. Skip to the Installation Instructions for ALL VEHICLES on Page #3.

## ALL VEHICLES

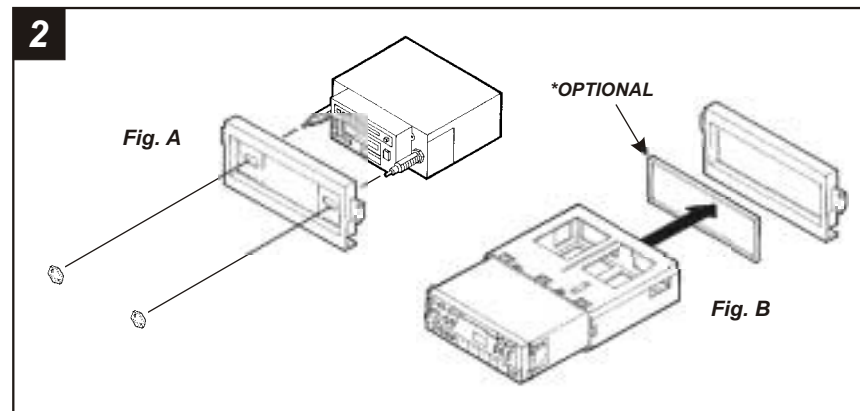

**2-SHAFT HEAD UNITS:** Slide the aftermarket head unit into the kit and secure with shaft nuts. (see Fig. A)

**DIN HEAD UNITS:** Insert the **Spacer\*** into the **Radio Housing**. Slide the DIN cage into the kit and secure by bending the metal locking tabs down. Slide the aftermarket head unit into the cage until secure. (see Fig. B)

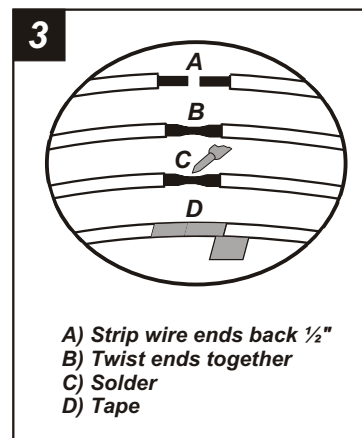

Locate the factory wiring harness in the dash. Metra recommends using the proper mating adaptor and making connections as shown. (Isolate and individually tape off the ends of any unused wires to prevent electrical short circuit).

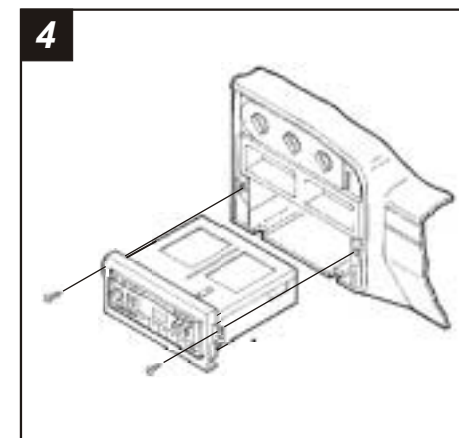

Re-connect the battery terminal and test the unit for proper operation. Mount the head unit/kit assembly to the sub-dash with those screws previously removed in step #1. (For the Malibu, use the center mounting positions).