

KIT FEATURES

- ▶ ISO-DIN unit provisions
- ▶ CD pocket holds (2) jewel cases

KIT COMPONENTS

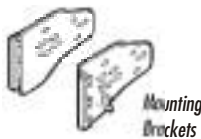

TOOLS REQUIRED



Phillips screwdriver



Socket wrench



99-3301 INSTALLATION INSTRUCTIONS

APPLICATIONS

CAR	PAGE
BUICK	
LeSabre 2000.....	1
CHEVROLET	
Cavalier 2000.....	1
Impala 2000.....	1
Monte Carlo 2000.....	1
Venture 2000.....	2
OLDMOBILE	
Silhouette 2000.....	2
PONTIAC	
Bonneville 2000.....	2
Montana 2000.....	2
Sunfire 2000.....	2

BUICK LeSabre 2000

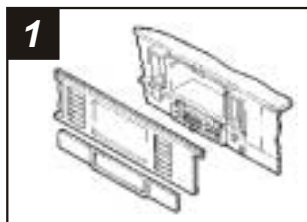

1 Disconnect the negative battery terminal to prevent an accidental short circuit. Open the glove box and remove (2) Phillips screws exposed. Unclip and remove the climate control trim bezel. Unclip the light control trim bezel and remove. Remove (1) 9/32" behind the steering column shifter. Remove (1) 9/32" from the right side of the factory radio trim bezel and remove the bezel. Depress the spring clips on each side of the factory head unit and remove. *Skip to the Installation Instructions for ALL VEHICLES on Page #3.*

CHEVROLET Cavalier 2000

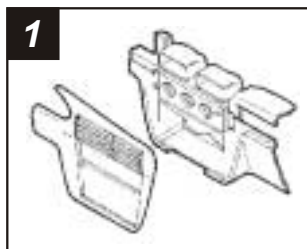

1 Disconnect the negative battery terminal to prevent an accidental short circuit. Remove (3) 7mm hex-head screws from the top of the glove box liner. Remove (2) 7mm hex-head screws from the top-left corner of the glove box cavity. Remove (1) Phillips screw from the defroster duct. Remove the duct work and (1) Phillips screw exposed. Unclip the dash trim piece and remove (2) Phillips screws exposed. Remove the dash pad and (3) Phillips screws exposed at the top of the radio trim bezel. *Skip to the Installation Instructions for ALL VEHICLES on Page #3.*

CHEVROLET Impala 2000

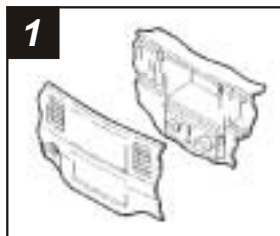

1 Disconnect the negative battery terminal to prevent an accidental short circuit. Unclip each side of the dash trim bezel (fuse access) and remove (1) Phillips screw exposed on each side. Remove (2) Phillips screws under the instrument cluster. Unclip the trim panel above the pedals. (It is not necessary to remove the panel, it can be left hanging). Remove (2) Phillips screws from the knee panel. Unclip the knee panel and remove (1) Phillips screw exposed on the right side of the steering column. Unclip and remove the entire dash trim bezel. *Skip to the Installation Instructions for ALL VEHICLES on Page #3.*

CHEVROLET Monte Carlo 2000

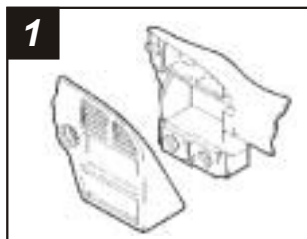

1 Disconnect the negative battery terminal to prevent an accidental short circuit. Unclip the trim panel above the pedals. (It is NOT necessary to remove the panel, it may be left hanging). Remove (2) 9/32" screws from the knee panel and unclip the panel. Unsnap the driver's side fuse panel cover and remove (1) 9/32" screw. Open the glove box and remove (1) 9/32" screw from the upper left corner. Remove (3) 9/32" screws securing the factory radio and disconnect the wiring. *Skip to the Installation Instructions for ALL VEHICLES on Page #3.*

CHEVROLET Venture/OLDSMOBILE Silhouette/PONTIAC Montana 2000

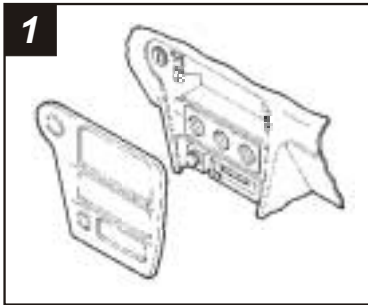

1 Disconnect the negative battery terminal to prevent an accidental short circuit. Remove the ashtray and (1) Phillips screw exposed in the ashtray cavity. Remove (1) Phillips screw from the cigarette lighter compartment. Remove (2) Phillips screws securing the factory head unit and disconnect the wiring. Skip to the Installation Instructions for ALL VEHICLES on Page #3.

PONTIAC Bonneville 2000

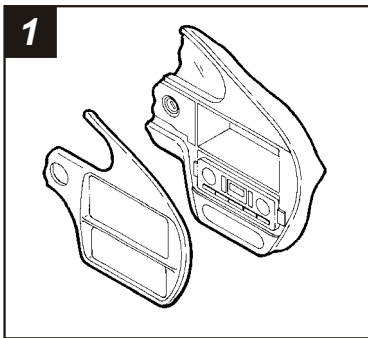

1 Disconnect the negative battery terminal to prevent an accidental short circuit. Remove (2) Phillips screws from the instrument cluster. Unclip the ignition trim and remove. Unclip the climate control/radio trim bezel and remove. Depress the spring clips on each side of the factory head unit and remove. Skip to the Installation Instructions for ALL VEHICLES on Page #3.

PONTIAC Sunfire 2000

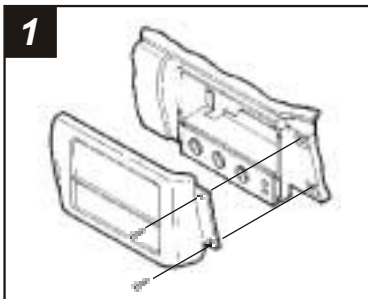

1 Disconnect the negative battery terminal to prevent an accidental short circuit. Open the glove box and remove (2) Phillips screws exposed on the right edge of the radio trim bezel. Unclip the bezel and remove. Remove (2) 7mm hex-head screws securing the factory head unit and disconnect the wiring. Skip to the Installation Instructions for ALL VEHICLES on Page #3.

ALL VEHICLES

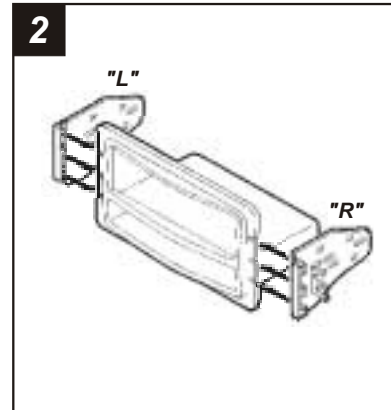

2 Slide **Mounting Brackets** ("L" and "R") into the slots on the sides of the **Radio Housing** as indicated.

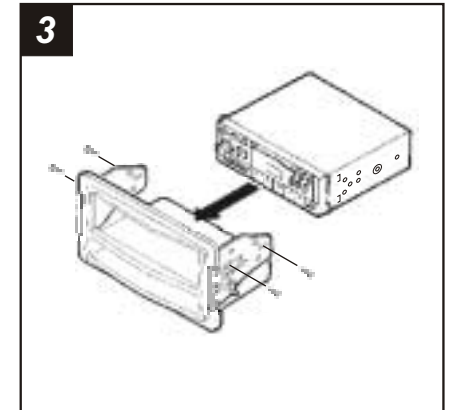

3 Slide the ISO-DIN head unit into the kit. Align the holes in the **Mounting Brackets** with the holes in the head unit and mount the Brackets to the head unit with the screws included with the unit.

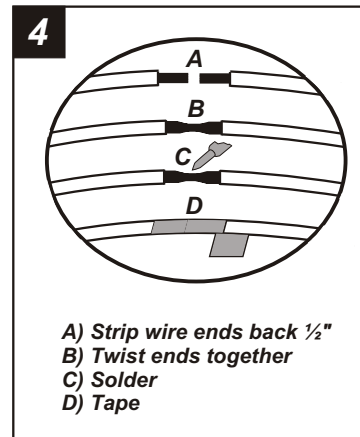

- A) Strip wire ends back $\frac{1}{2}$ "
- B) Twist ends together
- C) Solder
- D) Tape

4 Locate the factory wiring harness in the dash. Metra recommends using the proper mating adaptor and making connections as shown. (Isolate and individually tape off the ends of any unused wires to prevent electrical short circuit).

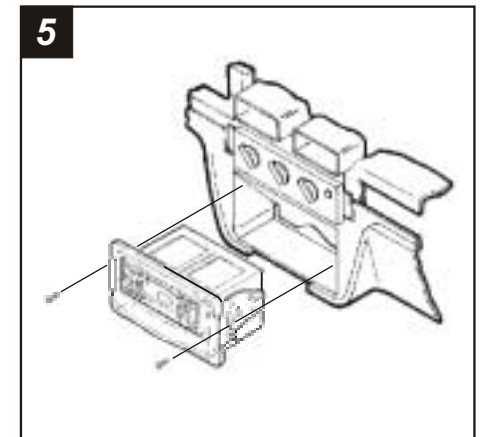

5 Re-connect the battery terminal and test the unit for proper operation. Mount the head unit/kit assembly to the sub-dash with those screws previously removed in step #1.