

KIT COMPONENTS

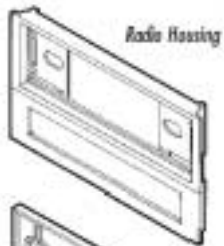

Radio Housing

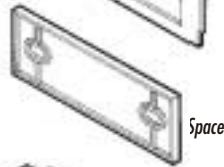

Spacer

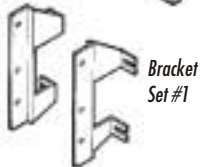

Bracket Set #1

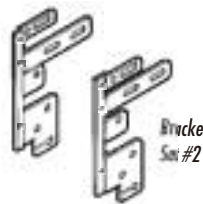

Bracket Set #2

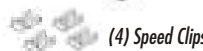

(4) Speed Clips



(6) #6 Phillips Screws



(4) #8 Phillips Screws

(2) Phillips Screws

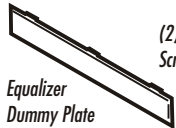

Equalizer Dummy Plate

TOOLS REQUIRED



Phillips screwdriver



Cutting tool



99-3400 AW-407GO DW-3400 INSTALLATION INSTRUCTIONS

APPLICATIONS

CAR

	PAGE
CHEVROLET	
Spectrum 1985-88.....	1
GEO	
Prizm 1989-92.....	2
Spectrum 1989.....	1
Storm 1990-93 (NOT keeping the factory pocket).....	3
Storm 1990-93 (keeping the factory pocket).....	4
HONDA	
Passport 1994-95.....	5
ISUZU	
Amigo 1991-94.....	5
I-Mark 1985-86.....	6
Impulse 1990-92 (NOT keeping the factory pocket).....	3
Impulse 1990-92 (keeping the factory pocket).....	4
Pickup 1988-95.....	5
Rodeo 1992-95.....	5
Stylus 1991-93 (NOT keeping the factory pocket).....	3
Stylus 1991-93 (keeping the factory pocket).....	4
Trooper 1988-91.....	5

**CHEVROLET Spectrum 1985-88
GEO Spectrum 1989**

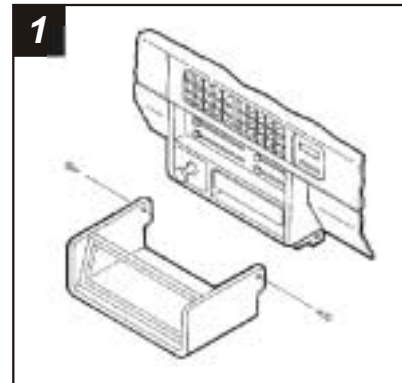

Disconnect the negative battery terminal to prevent an accidental short circuit. Remove (2) Phillips screws securing the radio trim bezel to the bottom of the dash and remove the bezel. Remove (2) screws securing the factory head unit to the sub-dash and disconnect the wiring.

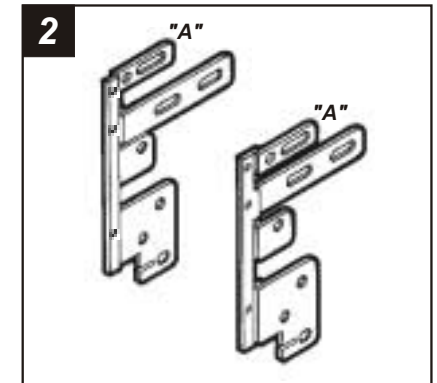

Cut and remove all mounting tabs on **Brackets Set #2** EXCEPT tabs "A". The mounting tabs can be identified by the stamped letter on the back of each tab.

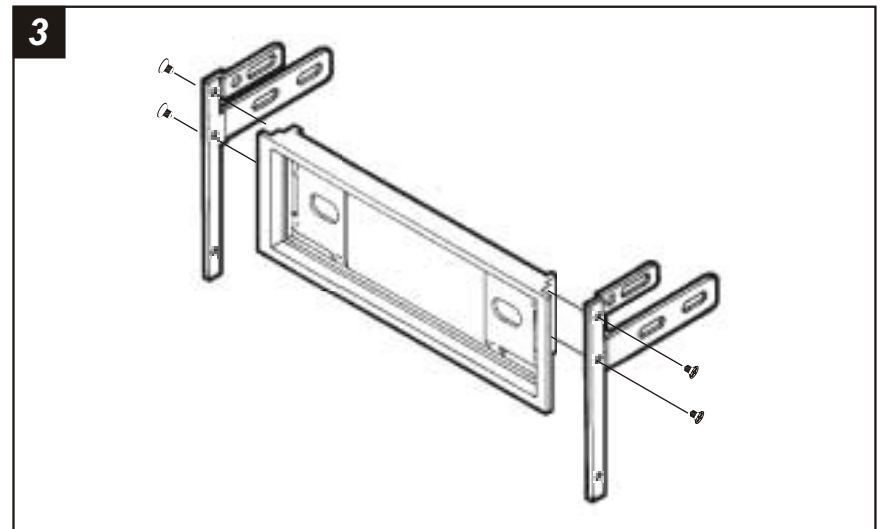

Using the v-cut as a guide, cut and remove the bottom portion of the **Radio Housing**. Mount the converted Brackets to the Housing with (4) #6 Phillips Screws supplied. Skip to the Installation Instructions for ALL VEHICLES on Page #7.

GEO Prizm 1989-92

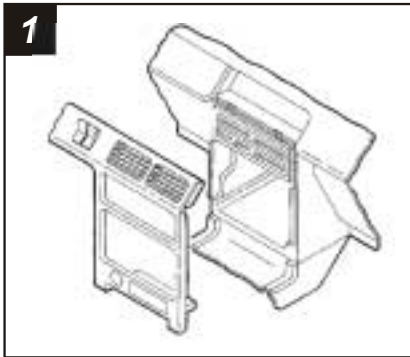

Disconnect the negative battery terminal to prevent an accidental short circuit. Remove (1) screw from each side of the steering column. Unclip the dash trim bezel and disconnect the cigarette lighter and illumination wiring. Remove (4) screws securing the factory head unit and disconnect the wiring.

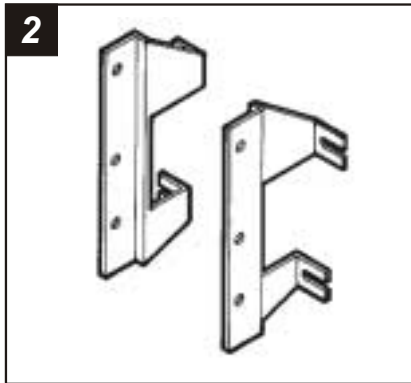

Locate **Bracket Set #1** and refer to step #3.

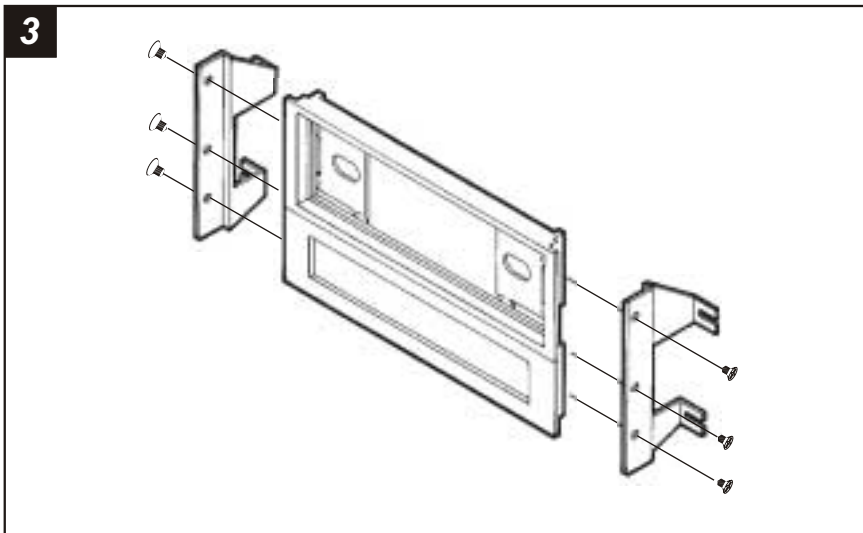

Mount the Brackets to the **Radio Housing** with (6) #6 Phillips Screws supplied. Skip to the *Installation Instructions for ALL VEHICLES* on Page #7.

GEO Storm 1990-93 ISUZU Impulse 1990-92 / Stylus 1991-93 (if keeping the factory pocket is NOT desired)

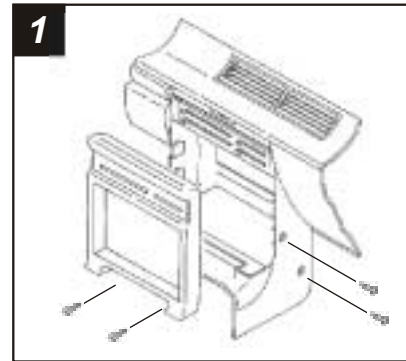

Disconnect the negative battery terminal to prevent an accidental short circuit. Remove the ashtray and the (2) outermost screws exposed in the ashtray cavity. Remove (2) screws from each side of the dash console. Remove the climate control knobs. Unclip the radio trim bezel. Remove (4) screws from the metal console support. Remove the factory head unit assembly and disconnect the wiring. Remove (4) screws securing the factory spacer plate to the radio brackets and remove the plate.

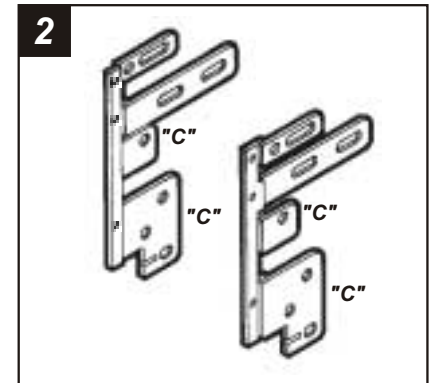

Cut and remove all mounting tabs on **Brackets Set #2** EXCEPT tabs "C". The mounting tabs can be identified by the stamped letter on the back of each tab.

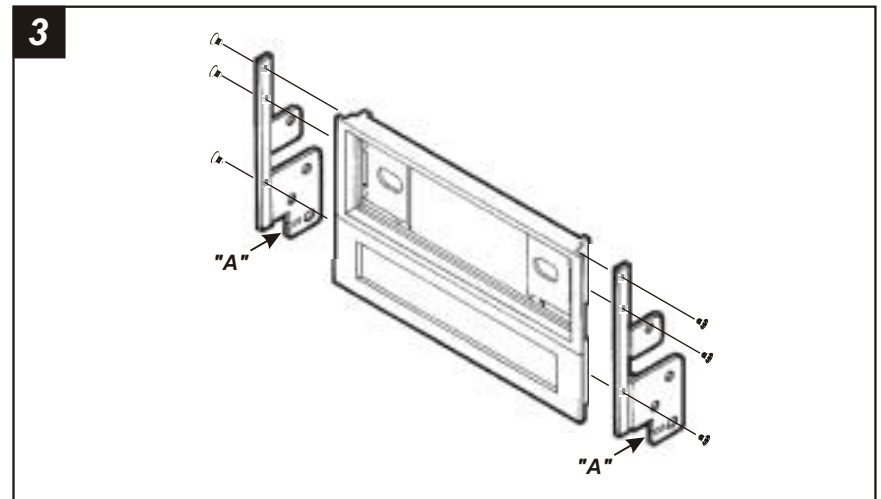

Mount the converted Brackets to the **Radio Housing** with (6) #6 Phillips Screws supplied. Slide the factory spacer plate onto the Brackets and mount through holes "A" with (2) Phillips Screws supplied. Skip to the *Installation Instructions for ALL VEHICLES* on Page #7.

GEO Storm 1990-93
ISUZU Impulse 1990-92 / Stylus 1991-93
 (if keeping the factory pocket is desired)

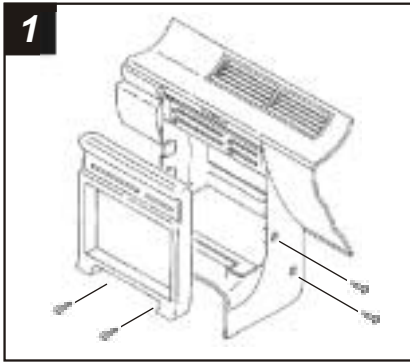

1
 Disconnect the negative battery terminal to prevent an accidental short circuit. Remove the ashtray and the (2) outermost screws exposed in the ashtray cavity. Remove (2) screws from each side of the dash console. Remove the climate control knobs. Unclip the radio trim bezel. Remove (4) screws from the metal console support. Remove the factory head unit assembly and disconnect the wiring. Remove (4) screws securing the factory spacer plate to the radio brackets and remove the plate.

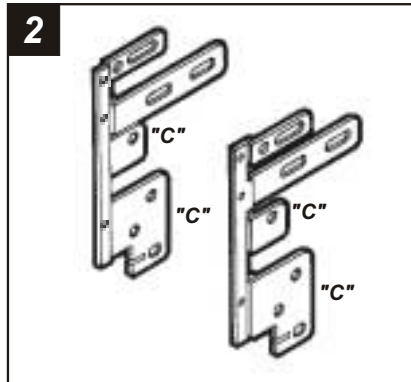

2
 Cut and remove all mounting tabs on **Brackets Set #2** EXCEPT tabs "C". The mounting tabs can be identified by the stamped letter on the back of each tab.

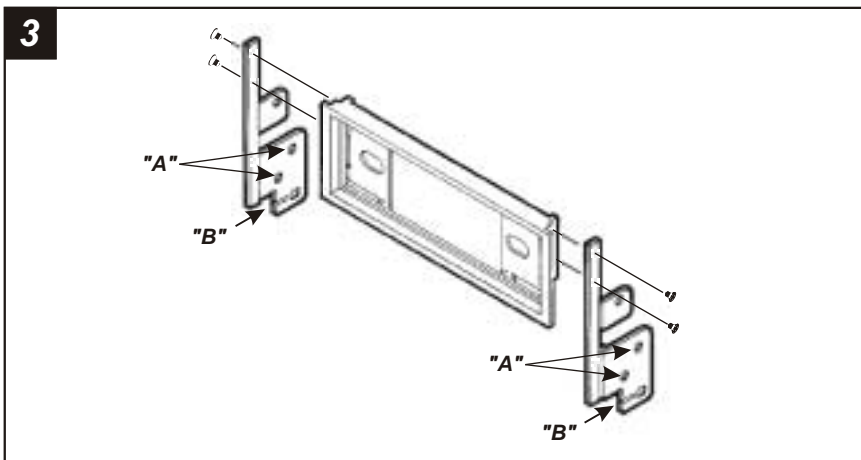

3
 Using the v-cut as a guide, cut and remove the bottom portion of the **Radio Housing**. Mount the Brackets to the Housing with (4) #6 Phillips Screws supplied. Mount the factory pocket to the Brackets through holes "A" with (4) #8 Phillips Screws supplied. (It may be necessary to trim the top and bottom edges of the pocket for a proper fit). Slide the factory spacer plate onto the Brackets and mount through holes "B" with (2) Phillips screws and (2) Speed Clips supplied. Skip to the Installation Instructions for ALL VEHICLES on Page #7.

HONDA Passport 1994-95
ISUZU Amigo 1991-94 / Pickup 1988-95
Rodeo 1992-95 / Trooper 1988-91

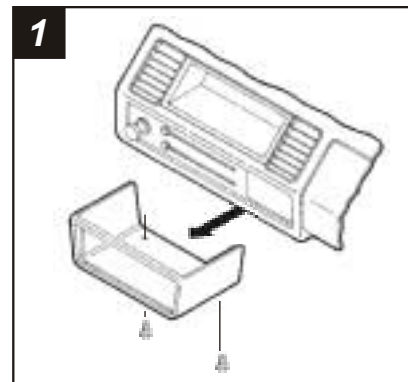

1
 Disconnect the negative battery terminal to prevent an accidental short circuit. Remove (2) Phillips screws from the base of the radio trim bezel and remove the bezel. Remove (3) hex-head bolts securing the factory head unit and disconnect the wiring.

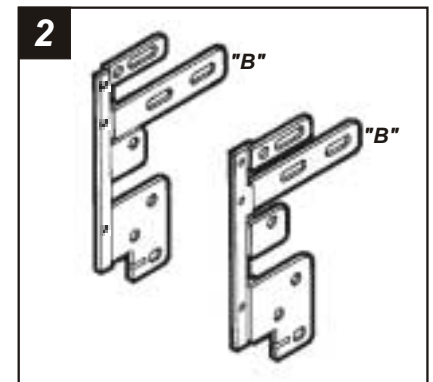

2
 Cut and remove all mounting tabs on **Brackets Set #2** EXCEPT tabs "B". The mounting tabs can be identified by the stamped letter on the back of each tab.

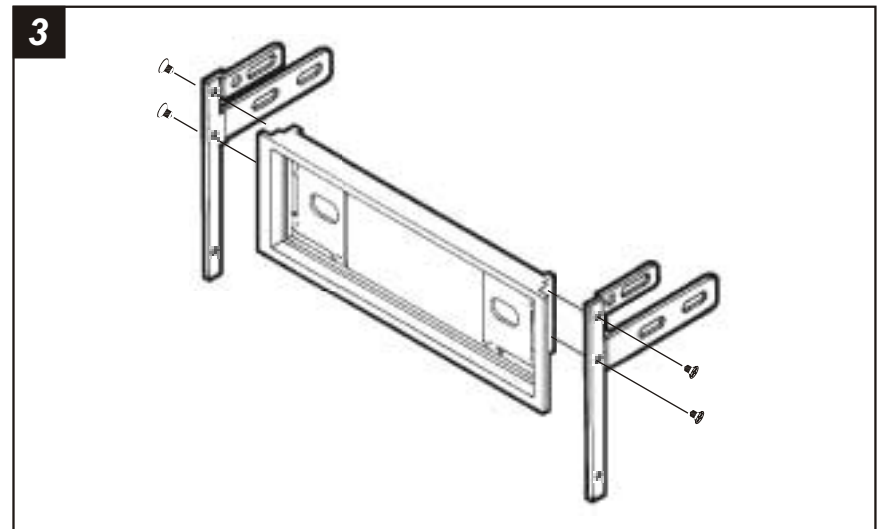

3
 Using the v-cut as a guide, cut and remove the bottom portion of the **Radio Housing**. Mount the converted Brackets to the Housing with (4) #6 Phillips Screws supplied. Skip to the Installation Instructions for ALL VEHICLES on Page #7.

ISUZU I-Mark 1985-88

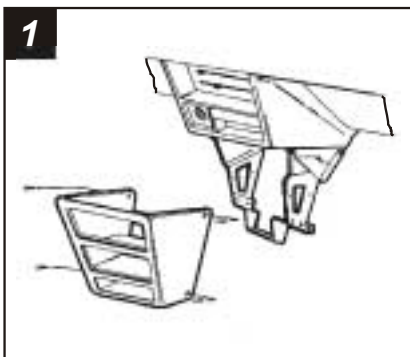

Disconnect the negative battery terminal to prevent an accidental short circuit. Remove (2) Phillips screws from each side of the dash trim bezel and remove the bezel. Remove (4) Phillips screws securing the bracket assembly. Remove the factory head unit and disconnect the wiring.

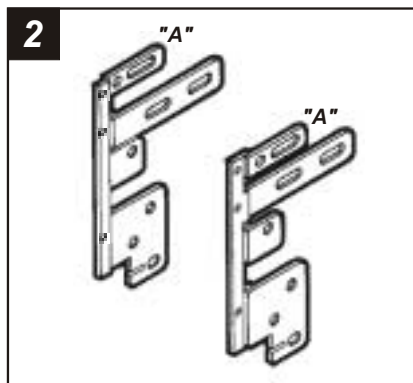

Cut and remove all mounting tabs on **Brackets Set #2** EXCEPT tabs "A". The mounting tabs can be identified by the stamped letter on the back of each tab.

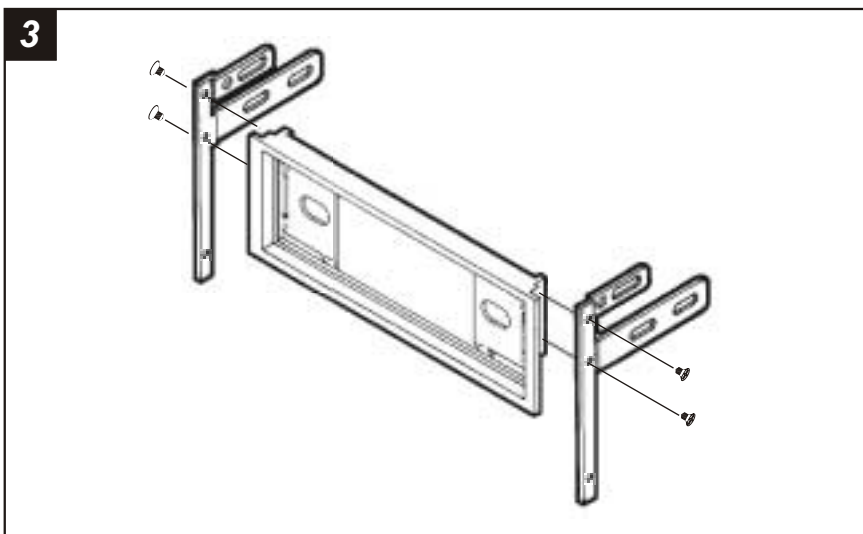

Using the v-cut as a guide, cut and remove the bottom portion of the **Radio Housing**. Mount the converted Brackets to the Housing with (4) #6 Phillips Screws supplied. Skip to the *Installation Instructions for ALL VEHICLES* on Page #7.

ALL VEHICLES

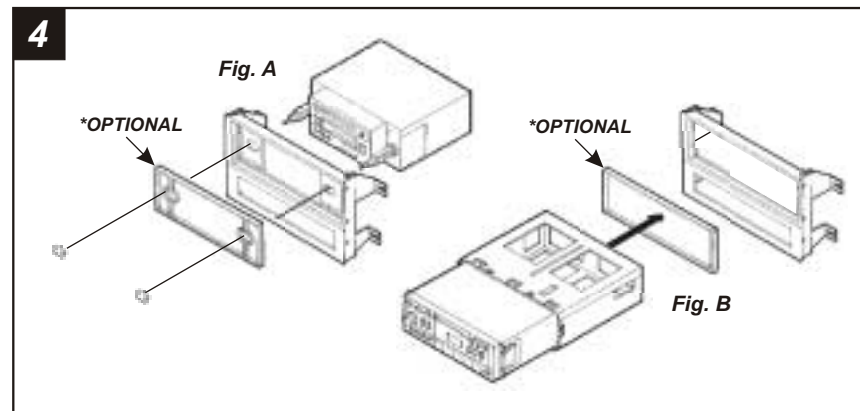

2-SHAFT HEAD UNITS: Attach the **Spacer*** to the **Radio Housing**. Slide the aftermarket head unit into the kit and secure with shaft nuts. (see Fig. A)

DIN HEAD UNITS: Cut and remove the shaft supports from the **Spacer*** and **Radio Housing**. Slide the DIN cage into the kit and secure by bending the metal locking tabs down. Slide the aftermarket head unit into the cage until secure. (see Fig. B)

(If an equalizer will be included, slide the unit into the back of the **Radio Housing** and secure. If an equalizer will NOT be included, snap the **Equalizer Dummy Plate** into the opening).

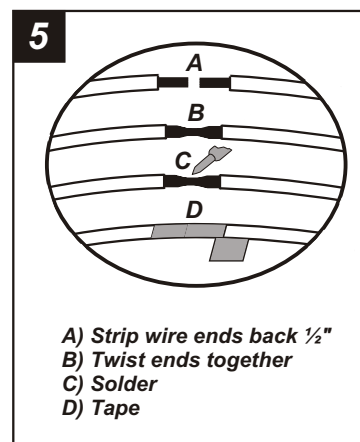

Locate the factory wiring harness in the dash. Metra recommends using the proper mating adaptor and making connections as shown. (Isolate and individually tape off the ends of any unused wires to prevent electrical short circuit).

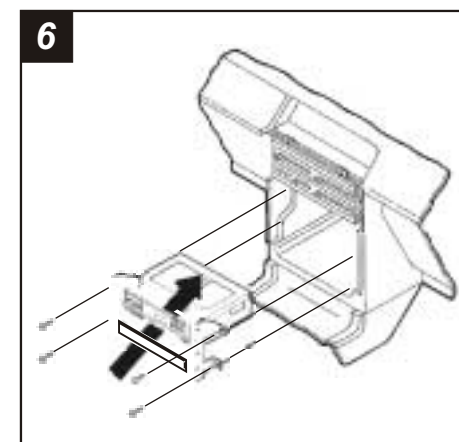

Re-connect the battery terminal and test the unit for proper operation. Mount the radio/kit assembly to the sub-dash with those screws previously removed in step #1.