

KIT FEATURES

- ▶ Shaft and DIN unit provisions
- ▶ Factory cupholder provisions

KIT COMPONENTS



TOOLS REQUIRED



99-3412

INSTALLATION INSTRUCTIONS

APPLICATIONS

<u>CAR</u>	<u>PAGE</u>
GEO	
Prizm 1993-97.....	1-2



ALL VEHICLES

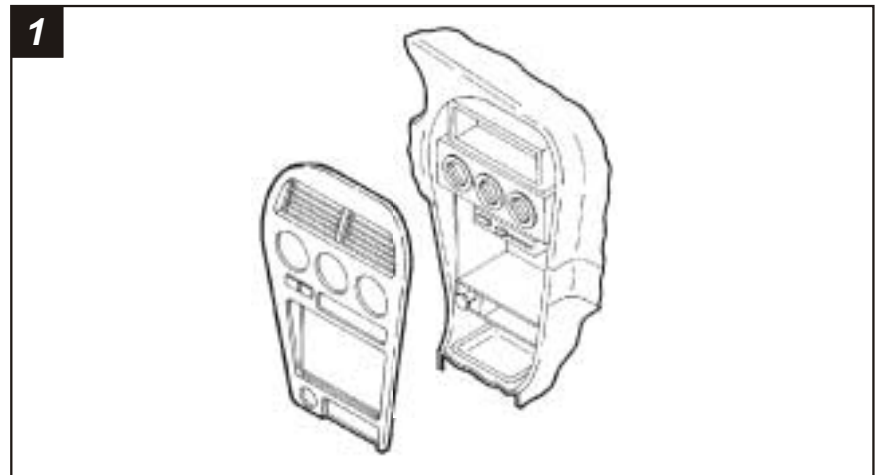

Disconnect the negative battery terminal to prevent an accidental short circuit. Remove the ashtray and (2) Phillips screws exposed. Remove the ashtray. Grasp the bottom edge of the dash trim bezel, pull out on the bezel and remove (it may be necessary to use a panel removal tool). Disconnect the hazard switch and cigarette lighter wiring and remove the panel. Remove (4) screws securing the factory head unit and disconnect the wiring.

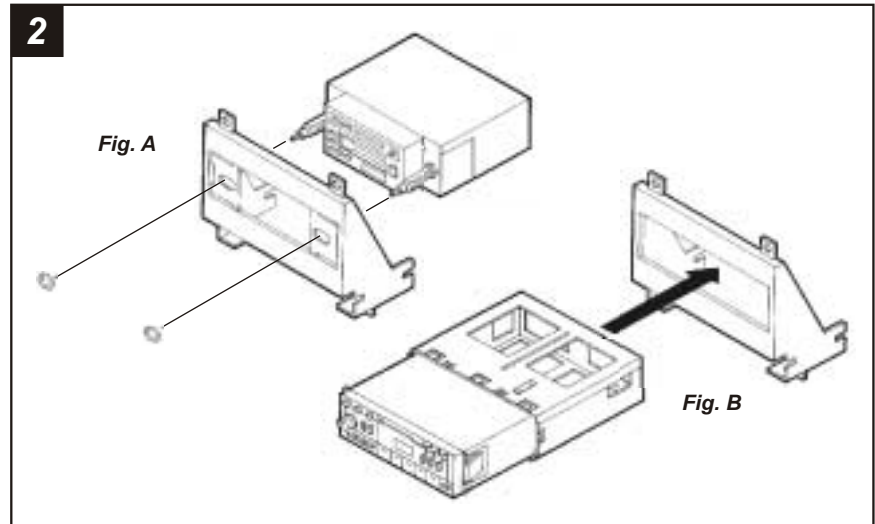

2-SHAFT HEAD UNITS: Slide the aftermarket head unit into the kit and secure with shaft nuts. (see Fig. A)

DIN HEAD UNITS: Cut and remove the shaft supports from the **Radio Housing**. Slide the DIN cage into the Housing and secure by bending the metal locking tabs down. Slide the aftermarket head unit into the cage until secure. (see Fig. B)

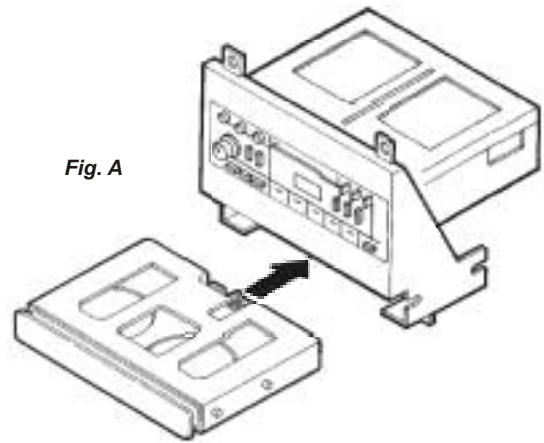
3*Fig. A*

Remove the cupholder from the factory head unit assembly. Slide the cupholder into the bottom of the **Radio Housing** until the bosses on the sides of the cupholder engage the slots in the Housing. (see *Fig. A*)

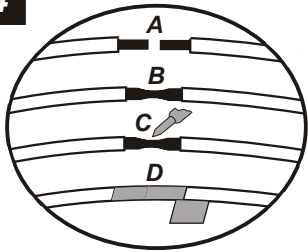
4

- A) Strip wire ends back ½"
- B) Twist ends together
- C) Solder
- D) Tape

Locate the factory wiring harness in the dash. Metra recommends using the proper mating adaptor and making connections as shown. (Isolate and individually tape off the ends of any unused wires to prevent electrical short circuit).

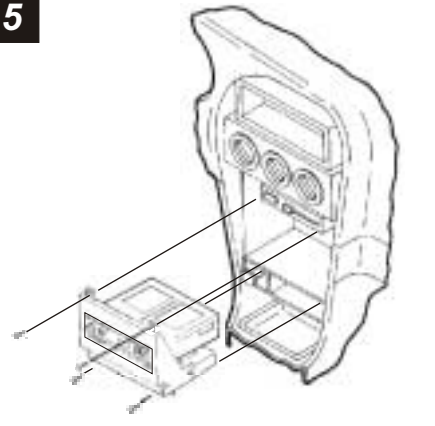
5

Re-connect the battery terminal and test the unit for proper operation. Mount the head unit/cupholder assembly to the sub-dash with (4) screws previously removed.