

CHEVROLET Prizm 1998-2002

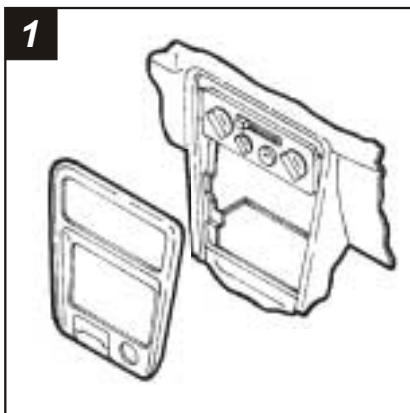

Disconnect the negative battery terminal to prevent an accidental short circuit. Remove the ashtray. Unclip the radio trim bezel and disconnect the wiring. Remove (4) Phillips screws securing the factory head unit/cupholder assembly, slide the assembly out and disconnect the wiring.

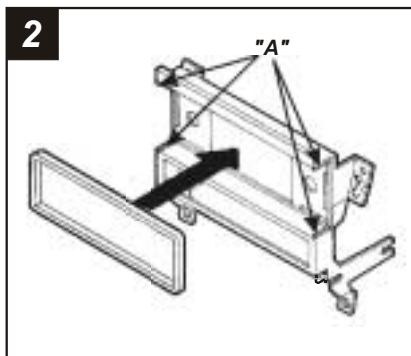

Locate the faceplate supplied with the aftermarket head unit. Place the faceplate into the recessed opening in the **Radio Housing**. If the faceplate fits easily into the opening with no interference, leave the Housing intact. If the faceplate does NOT fit easily into the opening, trim away the ribs located on the top and bottom of the opening ("A").

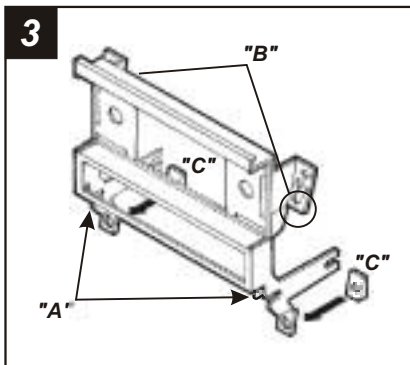

Convert the **Radio Housing** by cutting and removing the pins located under the equalizer opening ("A"). Trim no less than 1/8" and no more than 1/4" from the bottom of each upper mounting tab ("B"). Snap the **Prizm Spacers** onto the back of the lower mounting tabs ("C").

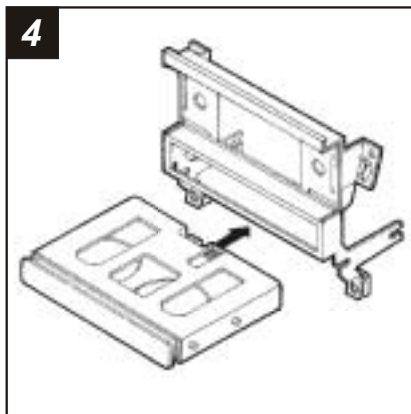

Remove the cupholder from the factory head unit assembly. Slide the cupholder into the bottom of the **Radio Housing** until the locating pins engage the slots in the kit. (Once the locating pins are engaged, PUSH the cupholder into the Housing until it stops). Skip to the Installation Instruction for ALL VEHICLES on Page #3.

TOYOTA Corolla 1998-2002

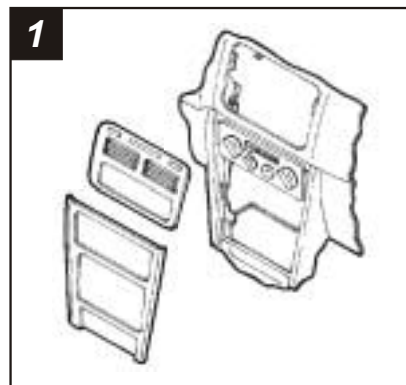

Disconnect the negative battery terminal to prevent an accidental short circuit. Unclip the radio trim bezel (upper dash). Remove (4) Phillips screws from the factory head unit, slide the unit out and disconnect the wiring. Remove the ashtray and unclip the trim bezel (lower dash). Remove (4) Phillips screws from the factory pocket/cupholder assembly and remove the assembly. (*Metra recommends ordering the 88-00-8000 or 88-00-9000 to fill the space left in the upper dash location*).

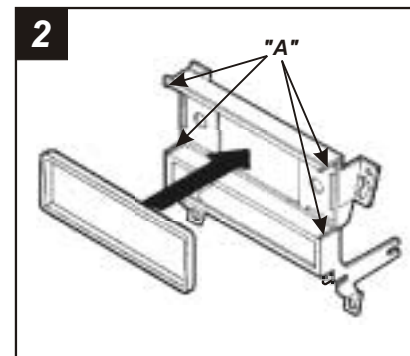

Locate the faceplate supplied with the aftermarket head unit. Place the faceplate into the recessed opening in the **Radio Housing**. If the faceplate fits easily into the opening with no interference, leave the Housing intact. If the faceplate does NOT fit easily into the opening, trim away the ribs located on the top and bottom of the opening ("A").

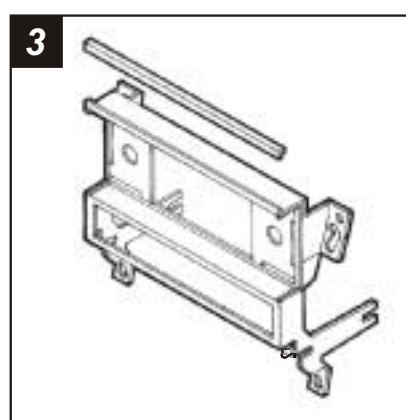

Locate the v-cut along the top lip of the **Radio Housing**. Using the v-cut as a guide, cut and remove the top portion of the Housing as indicated above.

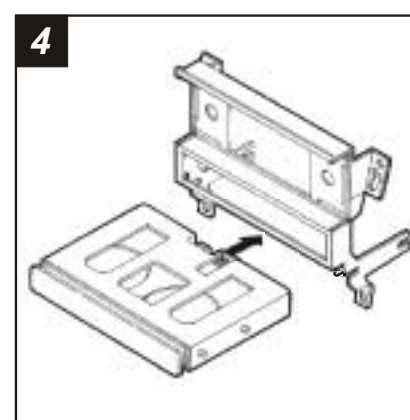

Remove the cupholder from the factory head unit assembly. Slide the cupholder into the bottom of the **Radio Housing** until the locating pins engage the slots in the kit. (Once the locating pins are engaged, maneuver the cupholder until it is flush with the face of the Housing). Skip to the Installation Instruction for ALL VEHICLES on Page #3.

ALL VEHICLES

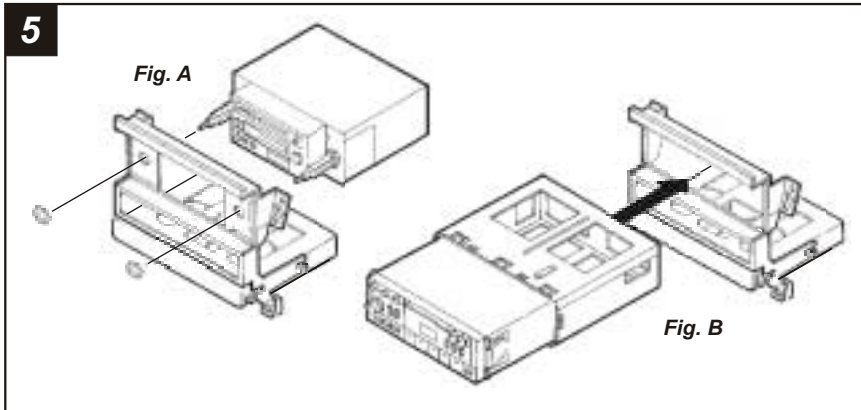

2-SHAFT HEAD UNITS: Slide the aftermarket head unit into the kit and secure with shaft nuts. (see Fig. A)

DIN HEAD UNITS: Cut and remove the shaft supports. Slide the DIN cage into the **Radio Housing** and secure by bending the metal locking tabs down. Slide the aftermarket head unit into the cage until secure. (see Fig. B)

(If an equalizer will be included, slide the unit into the back of the **Radio Housing** and secure. If an equalizer will NOT be included, snap the **Equalizer Dummy Plate** into the opening).

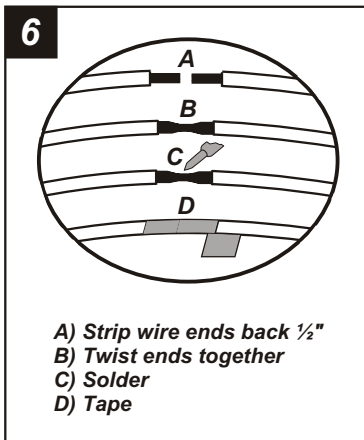

Locate the factory wiring harness in the dash. Metra recommends using the proper mating adaptor and making connections as shown. (Isolate and individually tape off the ends of any unused wires to prevent electrical short circuit).

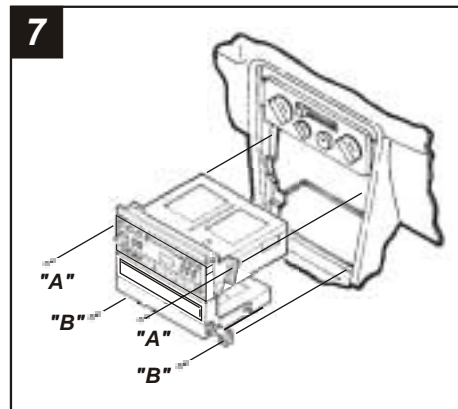

COROLLA: Re-connect the battery terminal and test the unit for proper operation. Mount the head unit/kit assembly to the sub-dash with (4) Phillips screws previously removed in step #1.

PRIZM: Re-connect the battery terminal and test the unit for proper operation. Mount the head unit/kit assembly to the sub-dash with (2) Phillips screws previously removed in step #1 ("A") and (2) Phillips Screws supplied ("B").

rev. 201202

KIT FEATURES

- ▶ Shaft and DIN unit provisions
- ▶ Cupholder provisions
- ▶ Equalizer provisions

KIT COMPONENTS

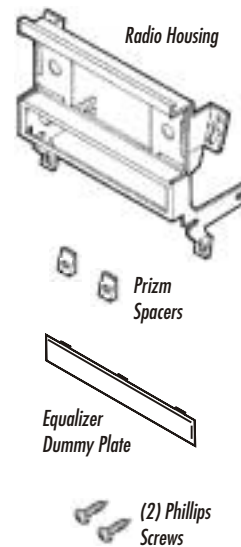

TOOLS REQUIRED



99-3413 INSTALLATION INSTRUCTIONS

APPLICATIONS

CAR	PAGE
CHEVROLET	
Prizm 1998-2002.....	1
TOYOTA	
Corolla 1998-2002.....	2

