

APPLICATIONS

BUICK

Century 1982-96*
Electra 1984-94*
Estate wagon 1984-94*
LeSabre 1984-94*
Park Ave. 1984-94*
Reatta 1990-91*
Regal 1984-87*
Riviera 1983-85*
Riviera 1990-95*
Roadmaster 1991-94*
Skyhawk 1982-89*
Skylark 1983-86*
Skylark 1987-89*
Skylark 1990-95*

CADILLAC

Cimarron 1982-88*
DeVille 1985-93*
Eldorado 1984-91*
Escalade 1999-02
Fleetwood 1985-93*
Seville 1984-91*

CHEVROLET

Astro 1985-89*
Astro 1990-95*
Astro 1996-02
Beretta 1991-96*
Blazer (full) 1989-91*
Blazer 1998-02
Camaro 1982-84*
Camaro 1985-92*

CHEVROLET (cont.)

Camaro 1997-02
Caprice 1991-93*
Caprice 1994-96
Cavalier 1982-90*
Cavalier 1991-94*
Cavalier 1995-99
Celebrity 1982-83*
Celebrity 1984-87*
Citation II 1985*
Corsica 1991-96*
Corvette 1984-89*
Corvette 1997-02
El Camino 1985-88*
Express 1996-00
Impala SS 1994-96
Lumina 1990-94*
Lumina 1995-01
Lumina APV 1990-95*
Lumina APV 1996*
Malibu 1997-01
Monte Carlo 1985-88*
Monte Carlo 1995-99
Nova 1985-88*
Pickup 1995-02
S10 Blazer 1982-85*
S10 Blazer 1986-94*
S10 Pickup 1982-85*
S10 Pickup 1986-93*
S10 Pickup 1998-02
Silverado 1999-02

CHEVROLET (cont.)

Suburban 1989-91*
Suburban 1995-02
Tahoe 1995-02
Van (full) 1988-95*
Venture 1997-99

GMC

Jimmy (full) 1988-91*
Jimmy 1998-02
S15 Jimmy 1982-85*
S15 Jimmy 1986-94*
S15 Pickup 1982-85*
S15 Pickup 1986-93*

OLDSMOBILE

Achieva 1992-95*
Bravada 1991-94*
Cutlass Calais 1985-91*
Cutlass Ciera 1984-96*
Cutlass Supr. 1984-88*
Delta 88 1986-88*
Firenza 1982-89*

OLDSMOBILE (cont.)

Ninety Eight 1984-90*
Omega 1983-84*
Silhouette 1990-95*
Silhouette 1996*
Silhouette 1997-99
Toronado 1983-85*

PONTIAC

6000 1982-91*
Bonneville 19852-86*
Bonneville 1987-93*
Bonneville 1994-99
Fiero 1984-88*
Firebird 1982-84*
Firebird 1985-92*
Firebird 1993-02
Grand Am 1985-91*
Grand Am 1992-95*
Grand Am 1996-98
Grand Am 1999-00
Grand Prix 1985-87*
Grand Prix 1990-93*
Grand Prix 1994-96
Grand Prix 1997-00
Montana 1999
Sunbird J-2000 1982-88*
Sunfire 1995-99
TransSport 1990-95*
TransSport 1996*
TranSport 1997-98

SATURN

(all models) 1991-94*

* THE FACTORY MOUNTING BRACKET(S) MUST BE RETAINED AND USED WITH THIS VEHICLE.

ALL VEHICLES

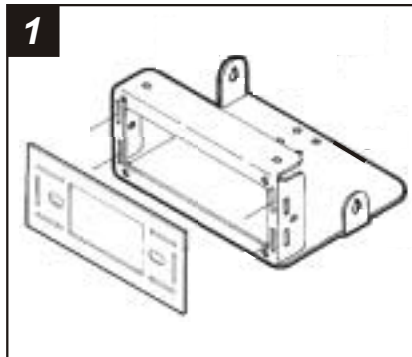

Please call Metra's Technical Support line for individual dash disassemblies.

Snap the **Faceplate** onto the front of the **Radio Housing**.

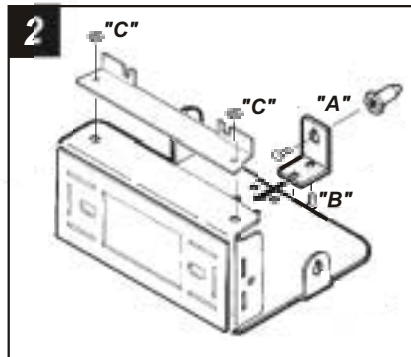

Mount the **Rear Support Bracket** to the **Rear Support Bracket** with (1) **Carriage Bolt** supplied ("A") and mount the **Rear Support Bracket** to the **Housing** with (2) **Hex-head Screws** supplied ("B"). Mount the **Metra bracket(s)** OR **factory bracket(s)** to the **Housing** with **Carriage Bolts** and **Keys Nuts** supplied ("C").

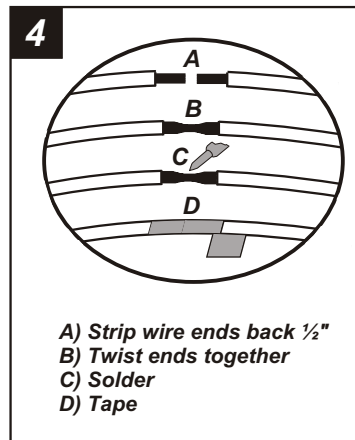

A) Strip wire ends back 1/2"
B) Twist ends together
C) Solder
D) Tape

Locate the factory wiring harness in the dash. Metra recommends using the proper mating adaptor and making connections as shown. (Isolate and individually tape off the ends of any unused wires to prevent electrical short circuit).

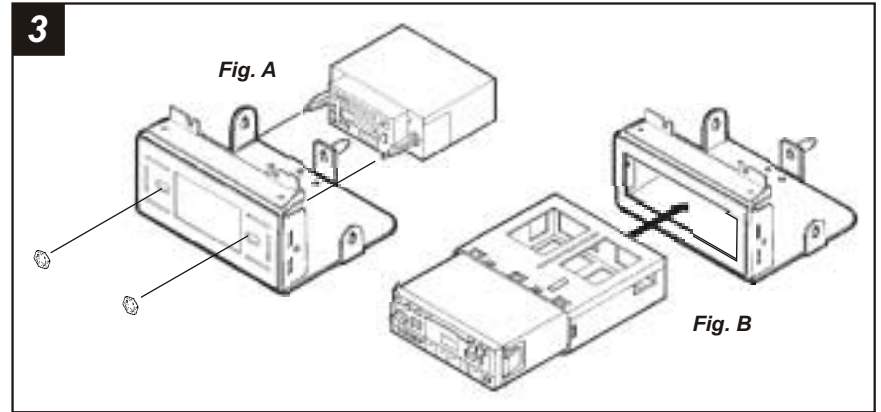

2-SHAFT HEAD UNITS: Slide the aftermarket head unit into the kit and secure with shaft nuts. (see Fig. A)

DIN HEAD UNITS: Cut and remove the shaft supports from the **Faceplate**. Slide the DIN cage into the **Radio Housing** and secure by bending the metal locking tabs down. Slide the aftermarket head unit into the cage until secure. (see Fig. B)

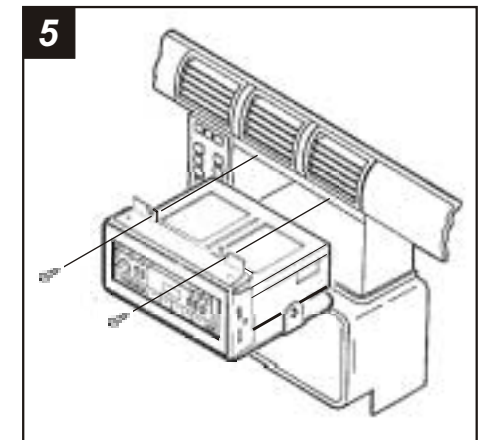

Re-connect the battery terminal and test the unit for proper operation. Mount the head unit/kit assembly to the sub-dash with those screws previously removed.

KIT FEATURES

- ▶ Shaft and DIN unit provisions

KIT COMPONENTS

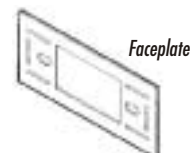
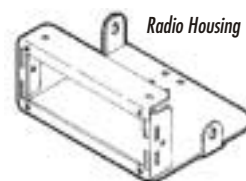

TOOLS REQUIRED



Phillips screwdriver



Cutting tool

99-4000-1 INSTALLATION INSTRUCTIONS

APPLICATIONS

**GENERAL MOTORS 1982-02
VEHICLES EQUIPPED WITH J-2000 PANEL-STYLE
FACTORY HEAD UNIT PROVISIONS
(SEE INSIDE FOR SPECIFIC APPLICATIONS)**

