

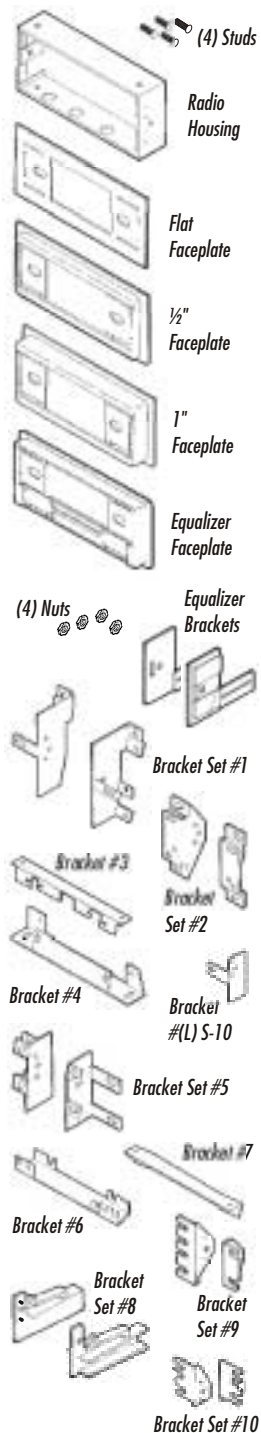

KIT COMPONENTS



99-4544

INSTALLATION INSTRUCTIONS

APPLICATIONS

**GENERAL MOTORS 1982-02
VEHICLES EQUIPPED WITH J-2000 PANEL-STYLE
FACTORY HEAD UNIT PROVISIONS
(SEE INSIDE FOR SPECIFIC APPLICATIONS)**



BUICK Reatta 1990-91

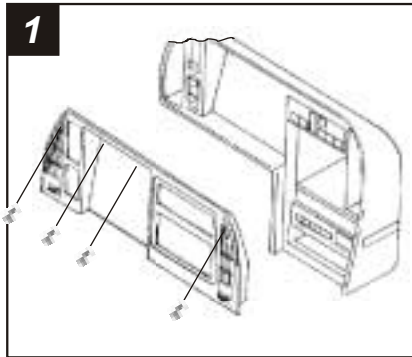

1
Disconnect the negative battery terminal to prevent an accidental short circuit. Remove (2) torx-head screws above the instrument panel. Remove (1) torx-head screw from each a/c vent. Unclip the dash trim bezel and remove.

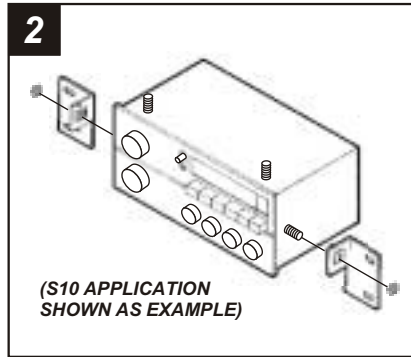

2
(S10 APPLICATION SHOWN AS EXAMPLE)
Remove the hardware securing the factory mounting brackets to the factory head unit. Remove and retain the brackets. Skip to the Installation Instructions for ALL VEHICLES on Page #34.

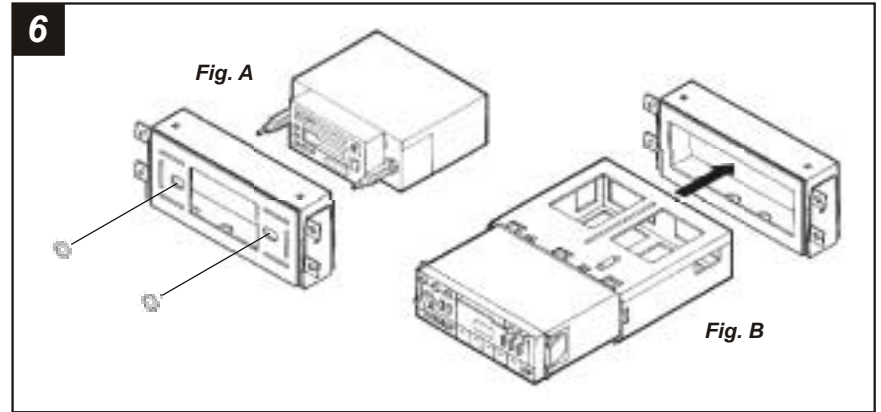

6
2-SHAFT HEAD UNITS: Slide the aftermarket head unit into the kit and secure with shaft nuts. (see Fig. A)

DIN HEAD UNITS: Cut and remove the shaft supports. Slide the DIN cage into the **Radio Housing** and secure by bending the metal locking tabs down. Slide the aftermarket head unit into the cage until secure. (see Fig. B)

BUICK Regal 1984-87

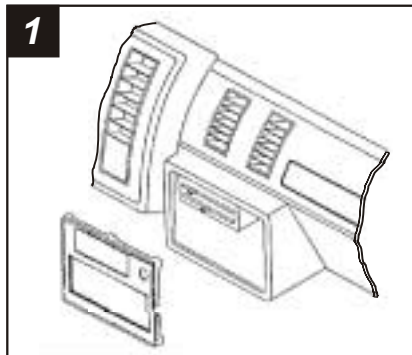

1
Disconnect the negative battery terminal to prevent an accidental short circuit. Remove the radio knobs and cigarette lighter. Gently unclip the radio trim bezel and remove.

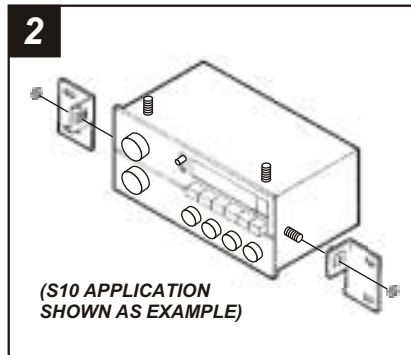

2
(S10 APPLICATION SHOWN AS EXAMPLE)
Remove the hardware securing the factory mounting brackets to the factory head unit. Remove and retain the brackets. Skip to the Installation Instructions for ALL VEHICLES on Page #34.

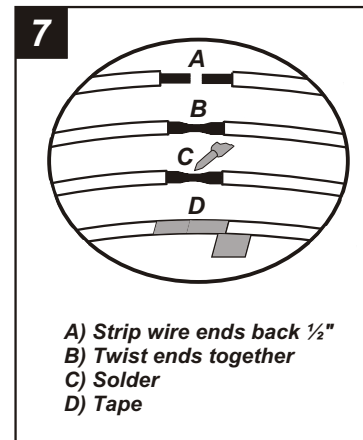

7
A) Strip wire ends back 1/2"
B) Twist ends together
C) Solder
D) Tape
Locate the factory wiring harness in the dash. Metra recommends using the proper mating adaptor and making connections as shown. (Isolate and individually tape off the ends of any unused wires to prevent electrical short circuit).

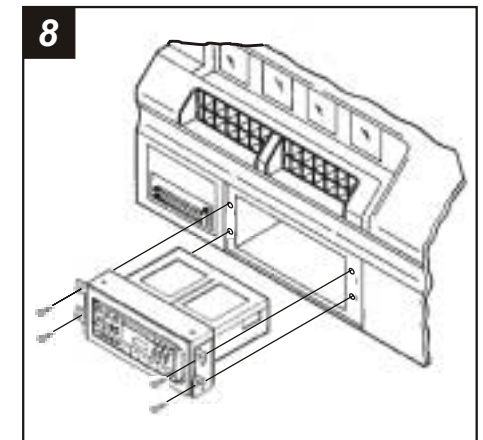

8
Re-connect the battery terminal and test the unit for proper operation. Mount the head unit/kit assembly to the sub-dash with those screws previously removed.

ALL VEHICLES

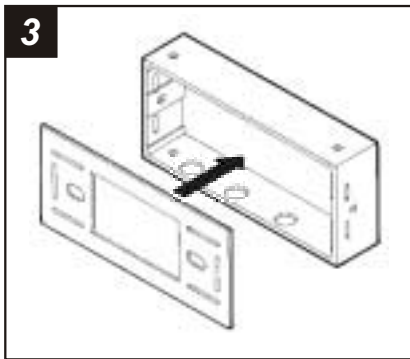

Choose a **Faceplate** (according to the desired installation depth) and snap it onto the front of the **Radio Housing**. (If an equalizer will be included in the installation, the **Equalizer Faceplate** must be used).

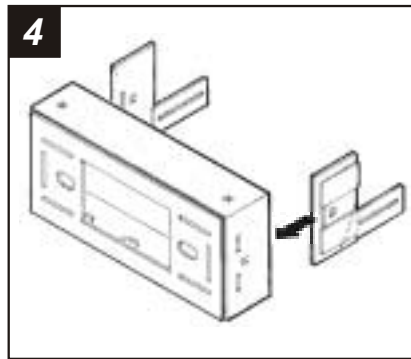

Slide the **Equalizer Brackets** into the slots along the inner walls of the **Radio Housing**.

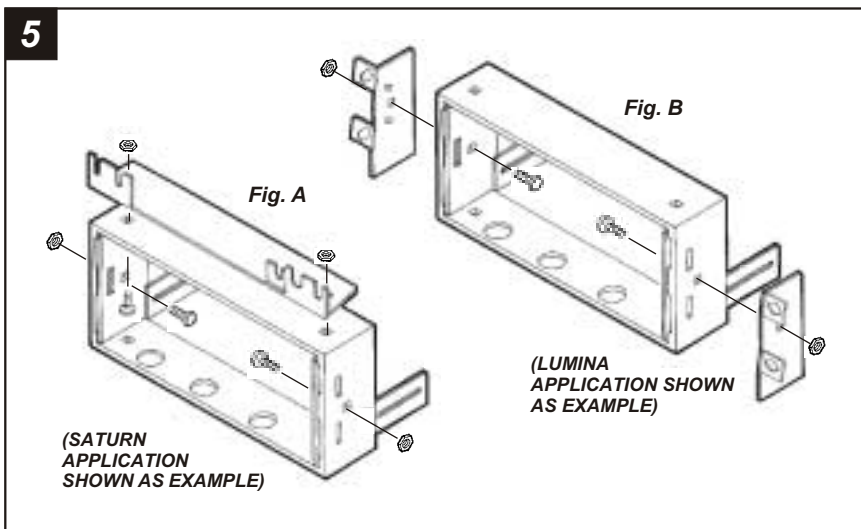

TOP AND/OR BOTTOM MOUNTING BRACKETS: Mount the **Equalizer Brackets** to the **Radio Housing** with (2) **Carriage Bolts** and (2) **Keps Nuts**. Secure the Mounting Bracket(s) to the Housing with Carriage Bolts and Keps Nuts. (see Fig. A)

SIDE MOUNTING BRACKETS: Secure the Mounting Brackets to the **Radio Housing** (through the center holes) with (2) **Carriage Bolts** and (2) **Keps Nuts**. (see Fig. B)

BUICK Riviera 1983-85

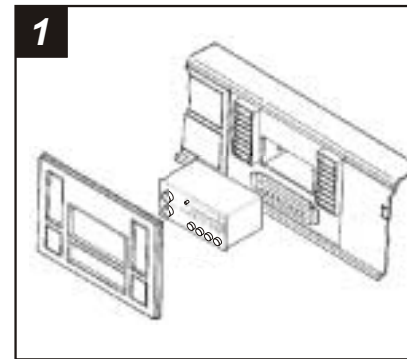

Disconnect the negative battery terminal to prevent an accidental short circuit. Carefully pull and remove the dash trim bezel. Remove (4) screws securing the factory head unit and disconnect the wiring.

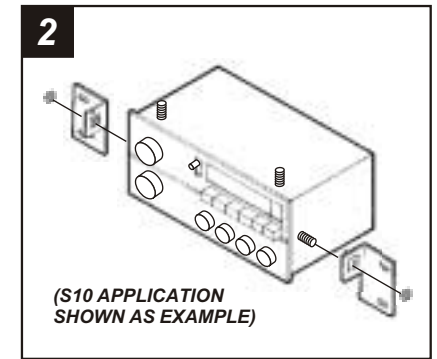

Remove the hardware securing the factory mounting brackets to the factory head unit. Remove and retain the brackets. Skip to the *Installation Instructions for ALL VEHICLES on Page #34*.

BUICK Riviera 1990-95

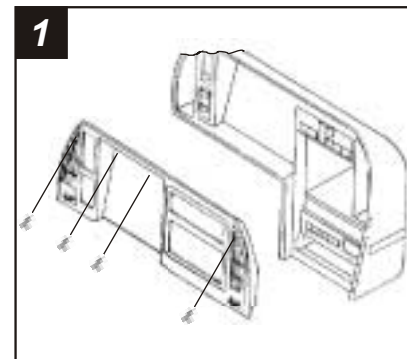

Disconnect the negative battery terminal to prevent an accidental short circuit. Remove (2) torx-head screws above the instrument cluster and (1) torx-head screw from each a/c vent. Unsnap the panel.

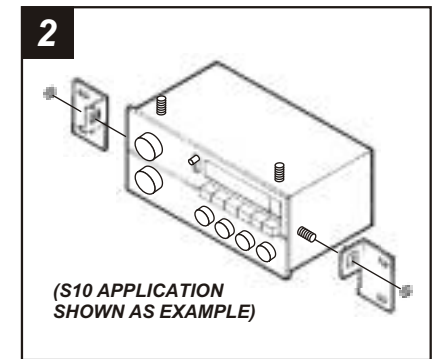

Remove the hardware securing the factory mounting brackets to the factory head unit. Remove and retain the brackets. Skip to the *Installation Instructions for ALL VEHICLES on Page #34*.

**BUICK Roadmaster 1991-94
CHEVROLET Caprice 1991-93**

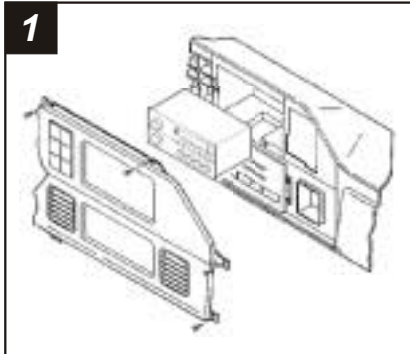

Disconnect the negative battery terminal to prevent an accidental short circuit. Remove (2) screws from the driver's side service panel and unclip the panel. Pry off the trim piece located above the glove box and remove (1) screw. Remove (3) screws from the top edge of the dash trim bezel. Remove (1) screw from the lower-left corner of the glove box and (1) screw from the parking brake release. Remove the dash trim bezel.

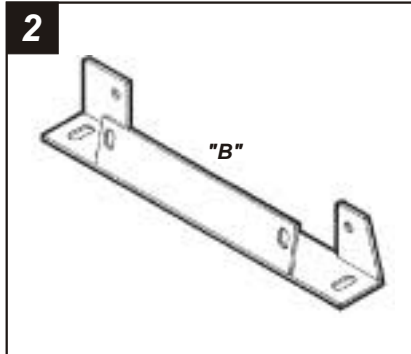

Cut and remove all mounting tabs on **Bracket #4** EXCEPT tabs "B". The mounting tabs can be identified by the stamped letter on the back of each tab. Skip to the *Installation Instructions for ALL VEHICLES* on Page #34.

BUICK Skyhawk / OLDSMOBILE Firenza 1982-89

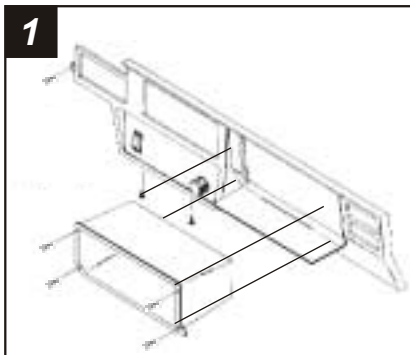

Disconnect the negative battery terminal to prevent an accidental short circuit. Remove the glove box by removing the doorstrap wire clip and (4) screws. Remove (2) screws below the cigarette lighter housing and (3) screws below the steering column. Remove (1) screw from the top-left of the factory head unit and unclip the dash trim bezel.

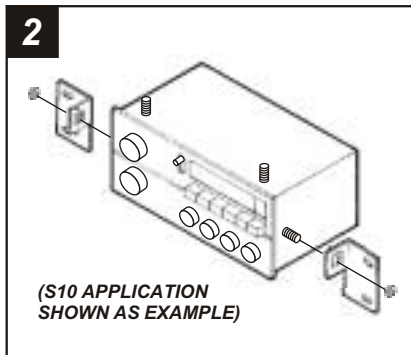

Remove the hardware securing the factory mounting brackets to the factory head unit. Remove and retain the brackets. Skip to the *Installation Instructions for ALL VEHICLES* on Page #34.

PONTIAC Sunfire 1995-99

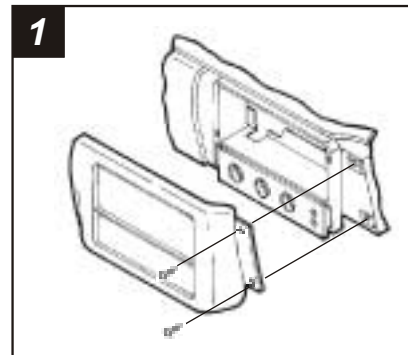

Disconnect the negative battery terminal to prevent an accidental short circuit. Open the glove box and remove (2) Phillips screws exposed on the right edge of the radio trim bezel. Unclip the bezel and remove. Remove (2) 7mm hex-head screws securing the factory head unit and disconnect the wiring.

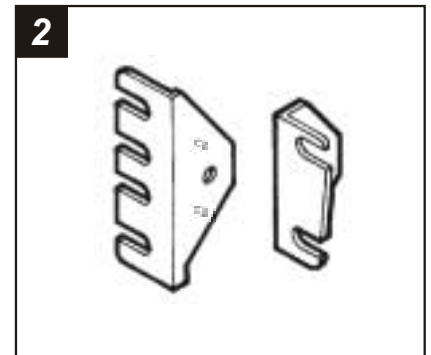

Locate **Bracket Set #9**. Skip to the *Installation Instructions for ALL VEHICLES* on Page #34.

SATURN (all models) 1991-94

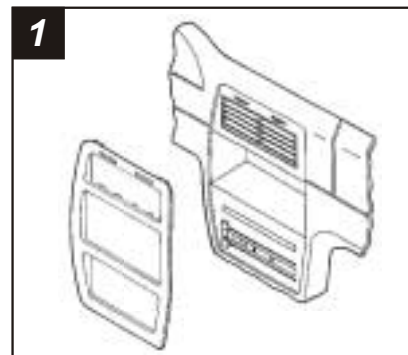

Disconnect the negative battery terminal to prevent an accidental short circuit. Gently unclip the dash trim bezel. Remove (2) screws from the factory head unit and disconnect the wiring.

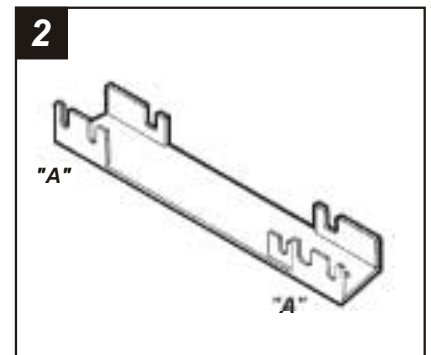

Cut and remove all mounting tabs on **Bracket #6** EXCEPT tabs "A". The mounting tabs can be identified by the stamped letter on the back of each tab. Skip to the *Installation Instructions for ALL VEHICLES* on Page #34.

PONTIAC Grand Prix 1994-96

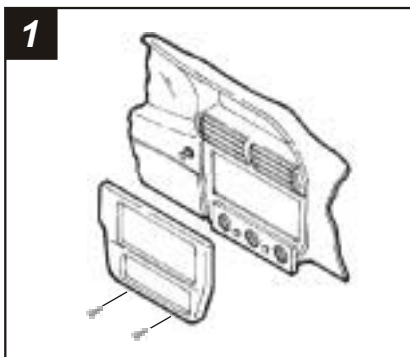

1
Disconnect the negative battery terminal to prevent an accidental short circuit. Using a small set of pliers, grasp the retaining clip on the back of the gear shifter handle and remove the clip. Remove the gear shifter handle. Unclip the center console and remove. Remove (2) 7mm hex-head screws exposed under the climate controls. Unclip the radio trim bezel and remove. Remove (2) 7mm hex-head screws securing the factory head unit and disconnect the wiring.

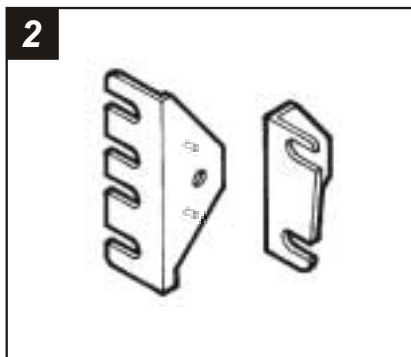

2
Locate **Bracket Set #9**. Skip to the *Installation Instructions for ALL VEHICLES on Page #34*.

BUICK Skylark 1983-85

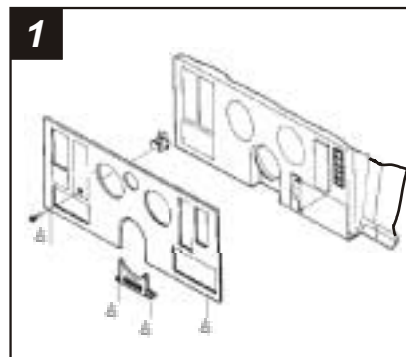

1
Disconnect the negative battery terminal to prevent an accidental short circuit. Remove (4) screws from the top edge of the instrument panel. Remove (1) screw from the bottom-left corner of the panel. Remove (2) screws from the steering column trim and remove the trim. Pull up and out on the dash trim bezel and remove.

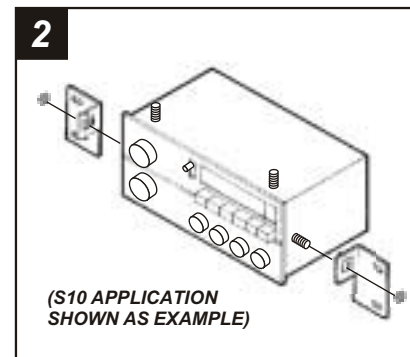

2
Remove the hardware securing the factory mounting brackets to the factory head unit. Remove and retain the brackets. Skip to the *Installation Instructions for ALL VEHICLES on Page #34*.

PONTIAC Grand Prix 1997-00

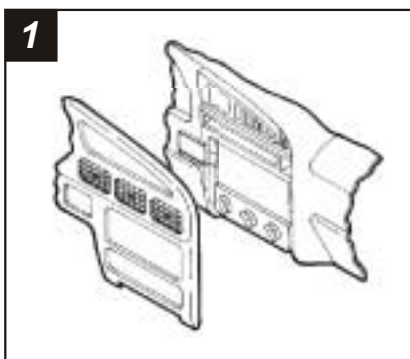

1
Disconnect the negative battery terminal to prevent an accidental short circuit. Unsnap the entire dash trim bezel. Remove the screws securing the factory head unit and disconnect the wiring.

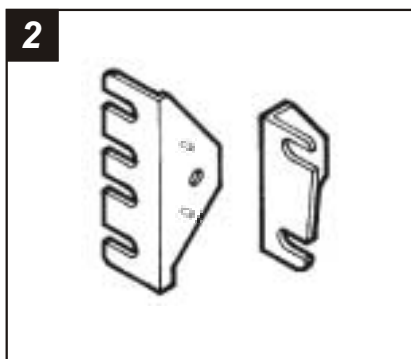

2
Locate **Bracket Set #9**. Skip to the *Installation Instructions for ALL VEHICLES on Page #34*.

BUICK Skylark 1987-89

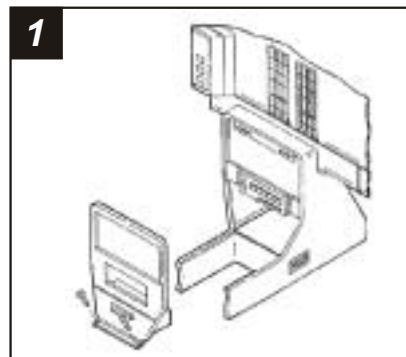

1
Disconnect the negative battery terminal to prevent an accidental short circuit. Unsnap the gear shifter bezel from the base of the console. Remove (2) screws securing the bottom of the dash trim bezel and remove the bezel.

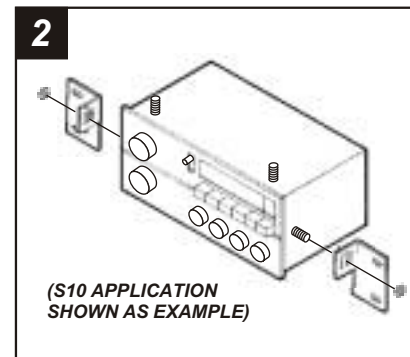

2
Remove the hardware securing the factory mounting brackets to the factory head unit. Remove and retain the brackets. Skip to the *Installation Instructions for ALL VEHICLES on Page #34*.

BUICK Skylark 1990-95

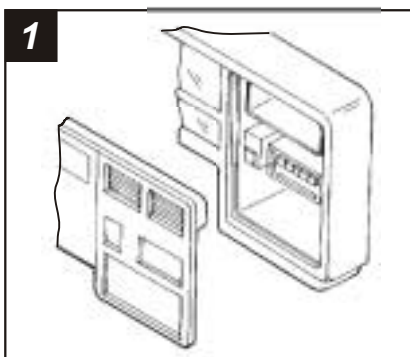

Disconnect the negative battery terminal to prevent an accidental short circuit. Pull out on the ashtray and remove (2) screws exposed in the ashtray cavity. Remove (2) screws securing the front of the ashtray and lower section of the dash trim bezel. Using a panel removal tool, gently pry out on the trim bezel and remove. Remove (2) nuts from the bottom of the factory head unit and disconnect the wiring.

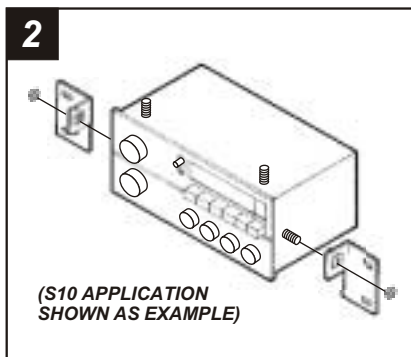

Remove the hardware securing the factory mounting brackets to the factory head unit. Remove and retain the brackets. *Skip to the Installation Instructions for ALL VEHICLES on Page #34.*

PONTIAC Grand Prix 1985-87 / Bonneville 1982-86

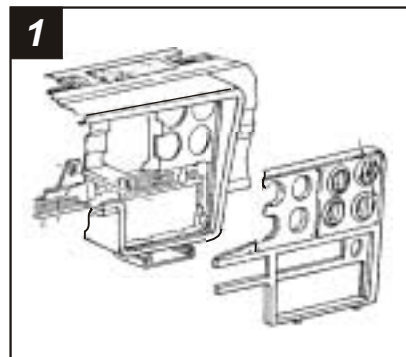

Disconnect the negative battery terminal to prevent an accidental short circuit. Remove (3) screws from the top edge of the dash trim bezel. Remove (4) screws from the metal steering column trim and remove the trim. Remove (4) screws exposed at the bottom edge of the dash trim bezel. Remove the cigarette lighter and retainer ring and remove the dash trim bezel.

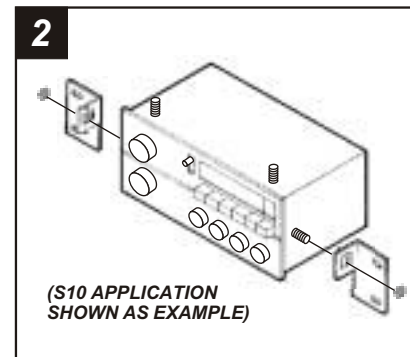

Remove the hardware securing the factory mounting brackets to the factory head unit. Remove and retain the brackets. *Skip to the Installation Instructions for ALL VEHICLES on Page #34.*

CADILLAC Deville / Fleetwood 1985-93

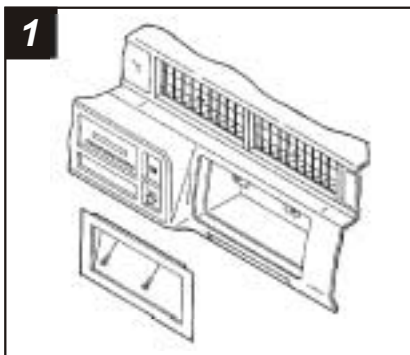

Disconnect the negative battery terminal to prevent an accidental short circuit. Remove (2) screws from the top of the radio trim bezel. Pull out on the top edge of the bezel and lift up to remove.

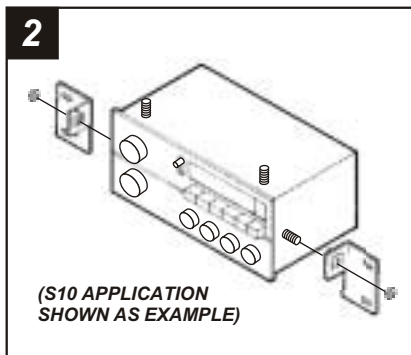

Remove the hardware securing the factory mounting brackets to the factory head unit. Remove and retain the brackets. *Skip to the Installation Instructions for ALL VEHICLES on Page #34.*

PONTIAC Grand Prix 1990-93

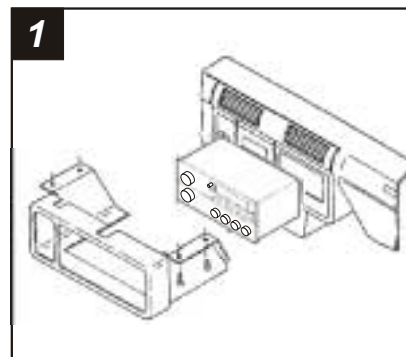

Disconnect the negative battery terminal to prevent an accidental short circuit. Remove (1) 9/32" hex-head screw from the computer diagnostic plug and twist to access (1) 9/32" screw on the trim panel. Remove (3) 9/32" screws from the bottom edge of the panel and remove. Open the glove box and remove (4) 9/32" screws from the dash trim bezel.

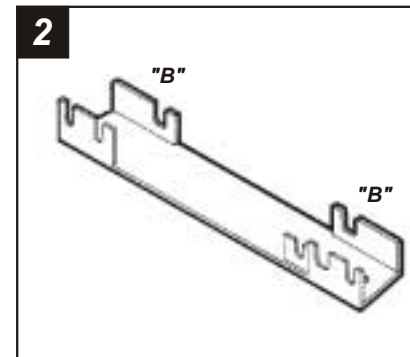

Cut and remove all mounting tabs on **Bracket #6** EXCEPT tabs "B". The mounting tabs can be identified by the stamped letter on the back of each tab. *Skip to the Installation Instructions for ALL VEHICLES on Page #34.*

PONTIAC Grand Am 1996-98

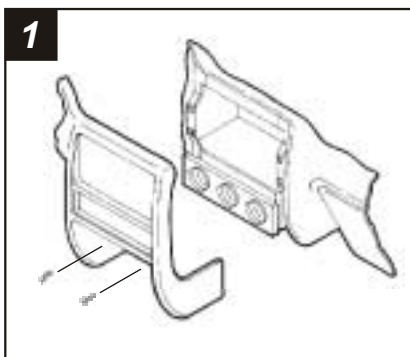

Disconnect the negative battery terminal to prevent an accidental short circuit. Remove (2) Phillips screws from the pocket. Remove (2) Phillips screws above the instrument cluster. Unclip the dash trim bezel and remove. Remove (3) 7mm hex-head screws securing the factory head unit and disconnect the wiring.

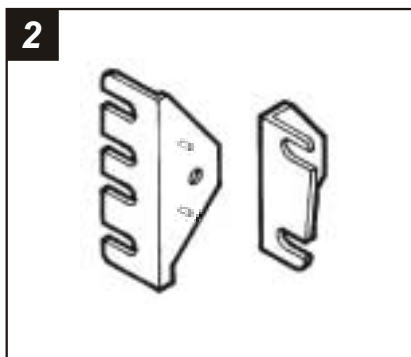

Locate **Bracket Set #9**. Skip to the *Installation Instructions for ALL VEHICLES on Page #34*.

CADILLAC Eldorado / Seville 1984-91

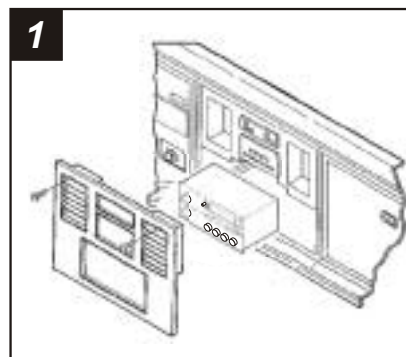

Disconnect the negative battery terminal to prevent an accidental short circuit. Remove (2) Phillips screws above the a/c vents. Pull out on the top edge of the dash trim bezel unhook the bottom edge and remove.

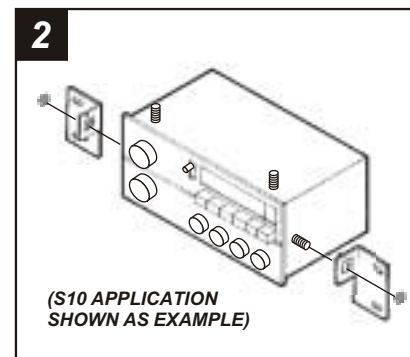

Remove the hardware securing the factory mounting brackets to the factory head unit. Remove and retain the brackets. Skip to the *Installation Instructions for ALL VEHICLES on Page #34*.

PONTIAC Grand Am 1999-00

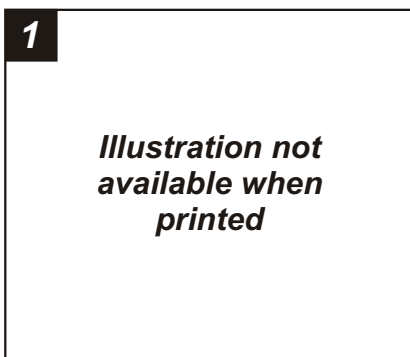

Disconnect the negative battery terminal to prevent an accidental short circuit. Unclip the radio trim bezel. Remove (3) 9/32" screws securing the factory head unit and disconnect the wiring.

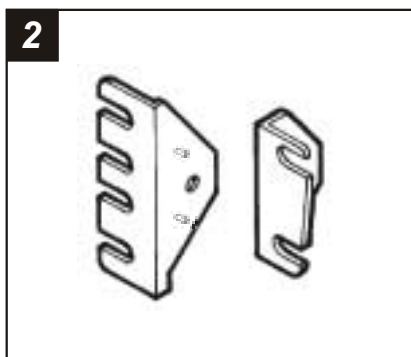

Locate **Bracket Set #9**. Skip to the *Installation Instructions for ALL VEHICLES on Page #34*.

CADILLAC Escalade 1999-02 CHEVROLET Pickup/Suburban/Tahoe 1995-02 • Silverado 1999-02 GMC Sierra/Suburban/Yukon 1995-02

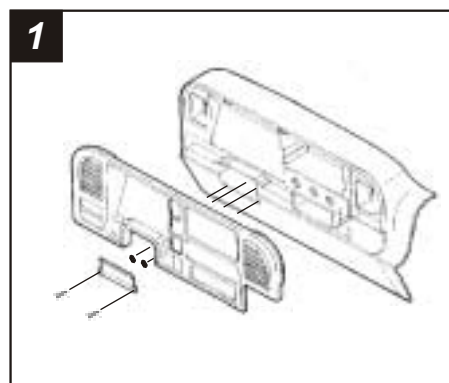

Disconnect the negative battery terminal to prevent an accidental short circuit. Remove the steering column filler panel and the ashtray. Unclip the dash trim bezel and remove. Using a small flat-blade screwdriver, press down on the outer clips of the factory head unit (or pocket). Disconnect the wiring and remove the unit.

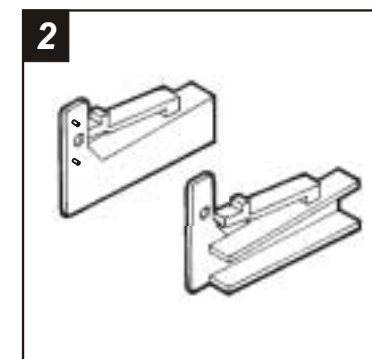

Locate **Bracket Set #8**. Skip to the *Installation Instructions for ALL VEHICLES on Page #34*.

CHEVROLET Astro / GMC Safari 1985-89

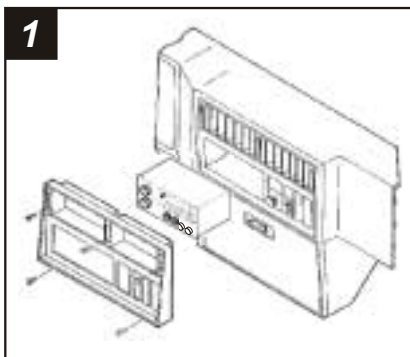

Disconnect the negative battery terminal to prevent an accidental short circuit. Remove (3) Phillips screws from the top portion of the dash trim bezel. Open the glove box and remove (2) 10mm bolts from the lower edge of the trim bezel. Pull the console trim forward and remove (2) 7mm bolts exposed. Gently unclip and remove the trim bezel. Remove (2) 7mm screws from the factory head unit and disconnect the wiring.

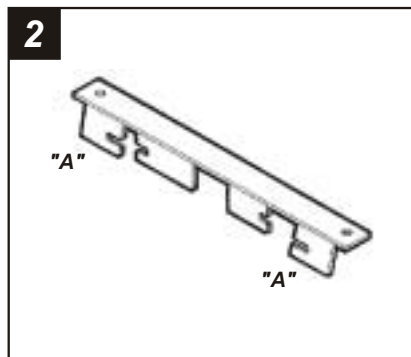

Cut and remove all mounting tabs on **Bracket #3** EXCEPT tabs "A". The mounting tabs can be identified by the stamped letter on the back of each tab. Skip to the *Installation Instructions for ALL VEHICLES on Page #34*.

PONTIAC Grand Am 1985-91

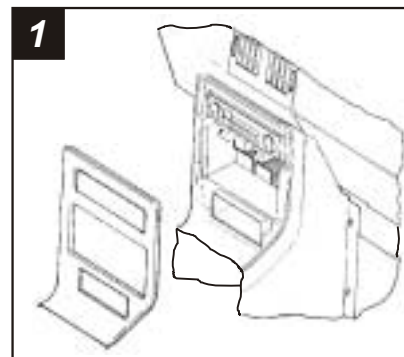

Disconnect the negative battery terminal to prevent an accidental short circuit. Carefully unsnap the front edge of the gear shifter console panel. Unsnap and remove the dash trim bezel.

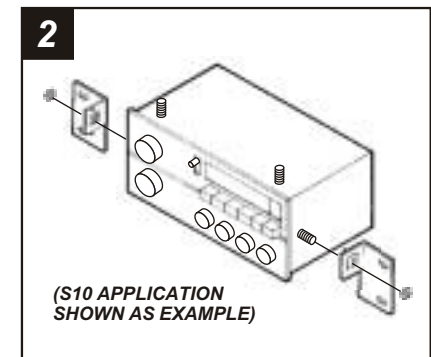

Remove the hardware securing the factory mounting brackets to the factory head unit. Remove and retain the brackets. Skip to the *Installation Instructions for ALL VEHICLES on Page #34*.

CHEVROLET Astro / GMC Safari 1990-95

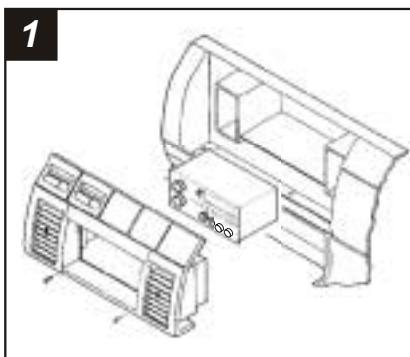

Disconnect the negative battery terminal to prevent an accidental short circuit. Remove (2) screws from the bottom of the dash trim bezel. Gently unclip and remove the bezel. Remove (4) screws from the factory head unit and disconnect the wiring.

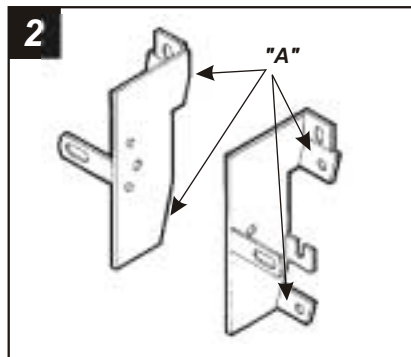

Cut and remove all mounting tabs on **Bracket #1** EXCEPT tabs "A". The mounting tabs can be identified by the stamped letter on the back of each tab. Skip to the *Installation Instructions for ALL VEHICLES on Page #34*.

PONTIAC Grand Am 1992-95

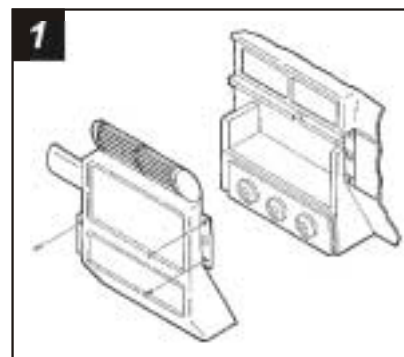

Disconnect the negative battery terminal to prevent an accidental short circuit. Remove (6) 7mm hex-head screws from the driver's side knee bolster panel and lower the panel. Remove (4) Phillips screws from the glove box/cupholder assembly. Remove (1) 7mm hex-head screw from the left corner of the dash trim bezel. Loosen (2) 10mm nuts from the top of the factory head unit, slide the unit out and disconnect the wiring.

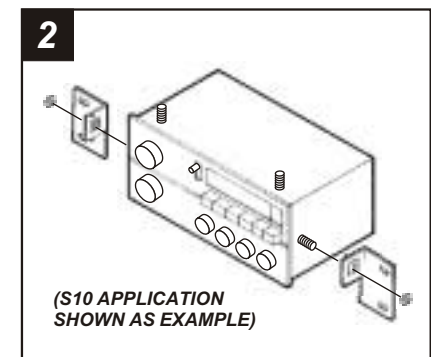

Remove the hardware securing the factory mounting brackets to the factory head unit. Remove and retain the brackets. Skip to the *Installation Instructions for ALL VEHICLES on Page #34*.

PONTIAC Fiero 1984-88

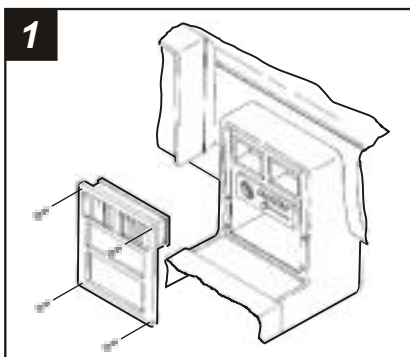

1
Disconnect the negative battery terminal to prevent an accidental short circuit. Remove (4) star-drive screws from the dash trim bezel. Gently pull out on the trim bezel and remove. Remove (4) hex-head screws from the factory head unit and disconnect the wiring.

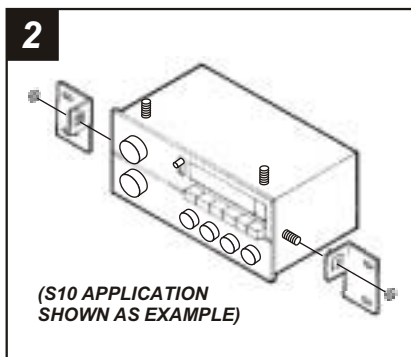

2
Remove the hardware securing the factory mounting brackets to the factory head unit. Remove and retain the brackets. *Skip to the Installation Instructions for ALL VEHICLES on Page #34.*

CHEVROLET Astro / GMC Safari 1996-02

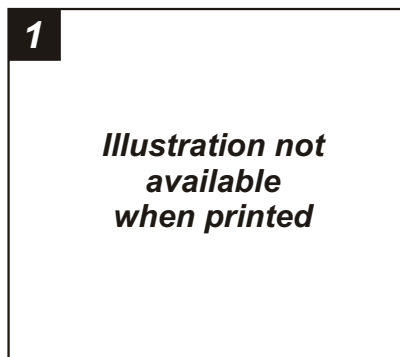

1
Illustration not available when printed

Disconnect the negative battery terminal to prevent an accidental short circuit. Place the gear selector in its lowest position. Unclip the perimeter of the dash trim bezel. Disconnect the rear a/c control harness and the headlight switch from the back of the dash trim bezel and remove the bezel. Using a flat-blade screwdriver, press down on the outside clips of the factory head unit and remove. *Skip to the Installation Instructions for ALL VEHICLES on Page #2.*

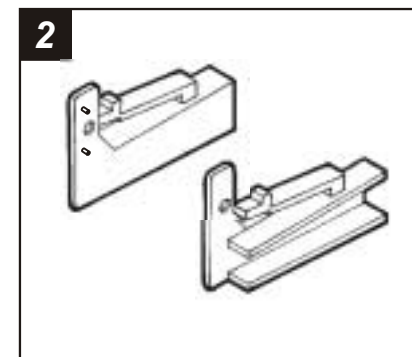

2
Locate **Bracket Set #8**. *Skip to the Installation Instructions for ALL VEHICLES on Page #34.*

PONTIAC Firebird 1993-02

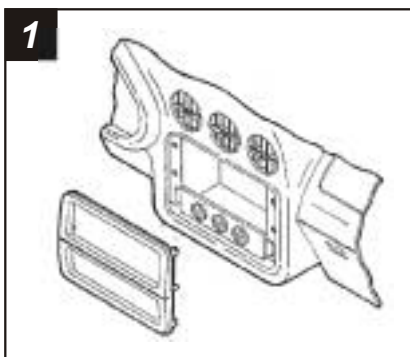

1
Disconnect the negative battery terminal to prevent an accidental short circuit. Unclip the radio trim bezel. Remove (4) 7mm hex-head screws securing the factory head unit and disconnect the wiring.

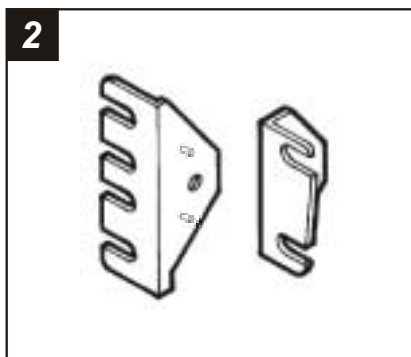

2
Locate **Bracket Set #9**. *Skip to the Installation Instructions for ALL VEHICLES on Page #34.*

CHEVROLET Beretta / Corsica 1991-96

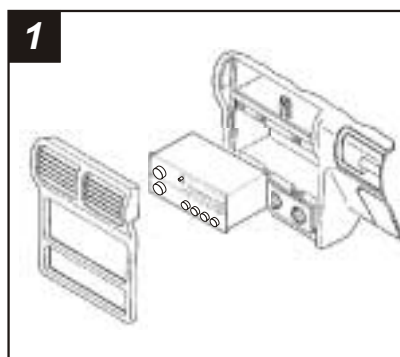

1
Disconnect the negative battery terminal to prevent an accidental short circuit. Using a panel removal tool, pry outward on the dash trim bezel and remove. Remove (2) screws securing the factory head unit and disconnect the wiring.

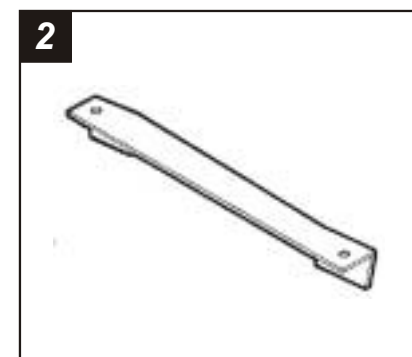

2
Locate **Bracket #7**. *Skip to the Installation Instructions for ALL VEHICLES on Page #34.*

**CHEVROLET Blazer (full size) / Suburban 1989-91
GMC Jimmy (full size) / Suburban 1989-91**

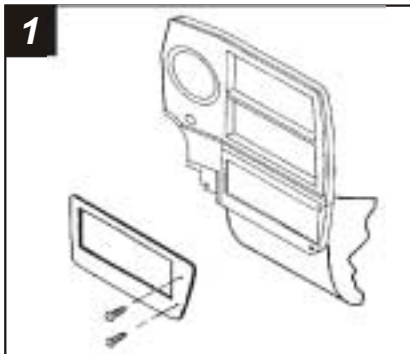

Disconnect the negative battery terminal to prevent an accidental short circuit. Remove (2) screws from the radio trim bezel and remove the bezel. Remove (2) screws securing the factory head unit and disconnect the wiring.

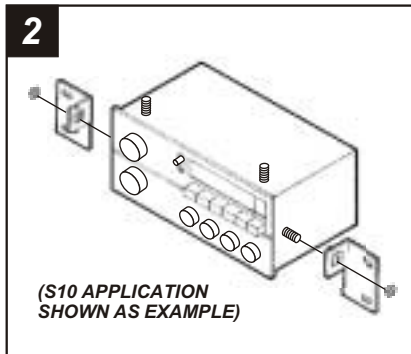

Remove the hardware securing the factory mounting brackets to the factory head unit. Remove and retain the brackets. *Skip to the Installation Instructions for ALL VEHICLES on Page #34.*

CHEVROLET Blazer/S-10 Pickup • GMC Jimmy/Sonoma 1998-02

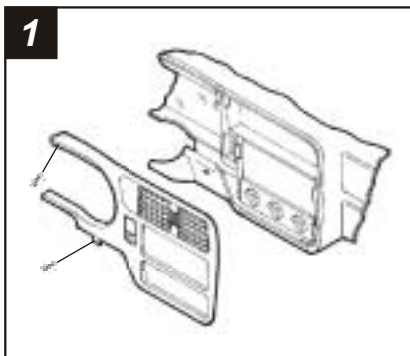

Disconnect the negative battery terminal to prevent an accidental short circuit. Remove (2) 9/32" hex-head screws from the knee bolster. Pull down on the bolster and remove 9/32" screws exposed on the base of the dash trim bezel. Remove (1) Phillips screw above the instrument cluster. Unclip the dash trim bezel and remove. Remove (2) 9/32" hex-head screws securing the factory head unit and disconnect the wiring. *Skip to the Installation Instructions for ALL VEHICLES on Page #3.*

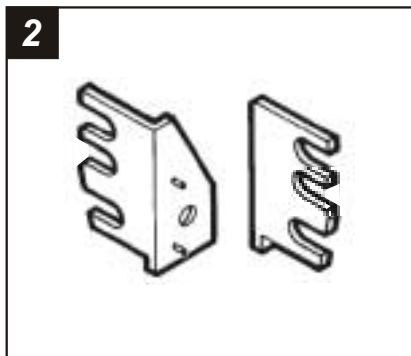

Locate **Bracket Set #10**. *Skip to the Installation Instructions for ALL VEHICLES on Page #34.*

PONTIAC Bonneville 1987-93

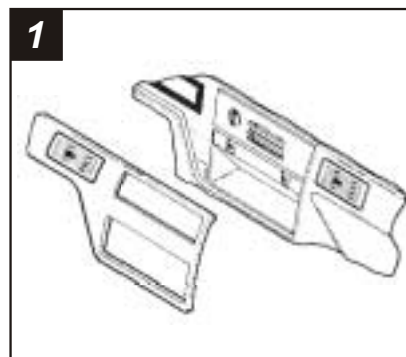

Disconnect the negative battery terminal to prevent an accidental short circuit. Gently unsnap and remove the dash trim bezel. Remove the screws securing the factory head unit and disconnect the wiring.

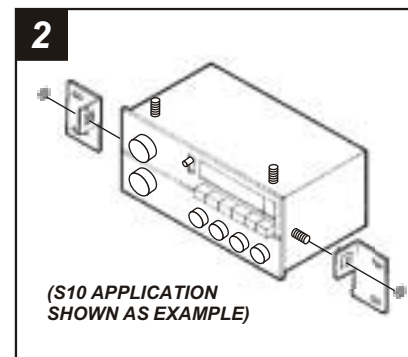

Remove the hardware securing the factory mounting brackets to the factory head unit. Remove and retain the brackets. *Skip to the Installation Instructions for ALL VEHICLES on Page #34.*

PONTIAC Bonneville 1994-99

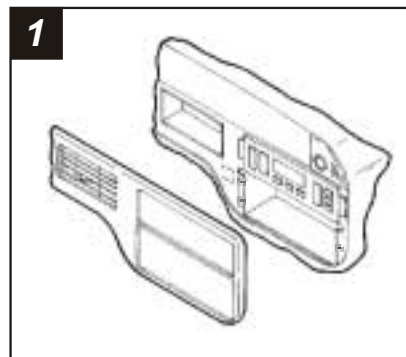

Disconnect the negative battery terminal to prevent an accidental short circuit. Unclip the right side of the dash trim bezel. Unclip the left side of the bezel and remove. Remove (3) 7mm hex-head screws securing the factory head unit and disconnect the wiring.

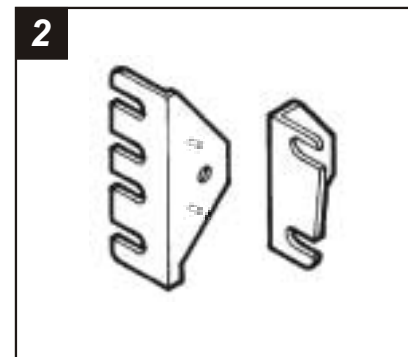

Locate **Bracket Set #9**. *Skip to the Installation Instructions for ALL VEHICLES on Page #34.*

OLDSMOBILE Toronado 1982-85

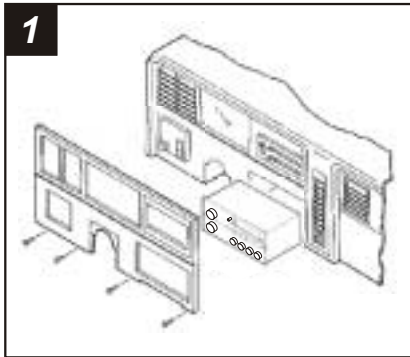

Disconnect the negative battery terminal to prevent an accidental short circuit. Depress the clip located behind the headlight knob and remove the knob. Remove (3) screws securing the steering column trim and remove. Remove (4) screws from the bottom edge of the dash trim bezel and remove.

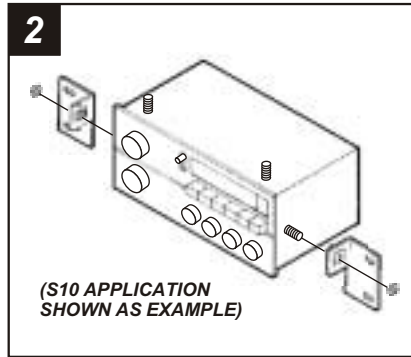

Remove the hardware securing the factory mounting brackets to the factory head unit. Remove and retain the brackets. *Skip to the Installation Instructions for ALL VEHICLES on Page #34.*

CHEVROLET Camaro / PONTIAC Firebird 1982-84

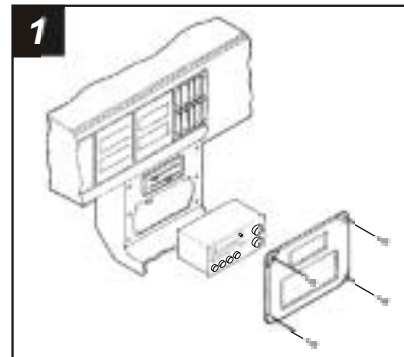

Disconnect the negative battery terminal to prevent an accidental short circuit. Remove (4) star-drive screws from the dash trim bezel and remove the bezel. Remove (4) screws securing the factory head unit and disconnect the wiring.

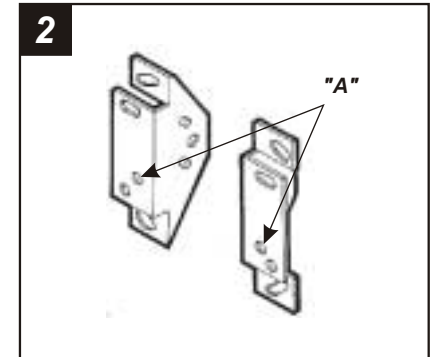

Cut and remove all mounting tabs on **Bracket #2** EXCEPT those tabs with holes "A". The mounting tabs can be identified by the stamped letter on the back of each tab. *Skip to the Installation Instructions for ALL VEHICLES on Page #34.*

PONTIAC 6000 1982-91

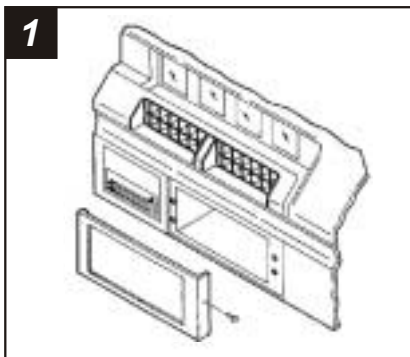

Disconnect the negative battery terminal to prevent an accidental short circuit. Open the glove box and remove (1) screw from the side of the radio trim bezel. Gently remove the bezel from the dash and the dummy plate from the bezel.

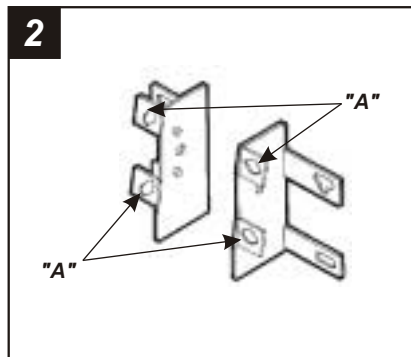

Cut and remove all mounting tabs on **Bracket #5** EXCEPT tabs "A". The mounting tabs can be identified by the stamped letter on the back of each tab. *Skip to the Installation Instructions for ALL VEHICLES on Page #34.*

CHEVROLET Camaro / PONTIAC Firebird 1985-92

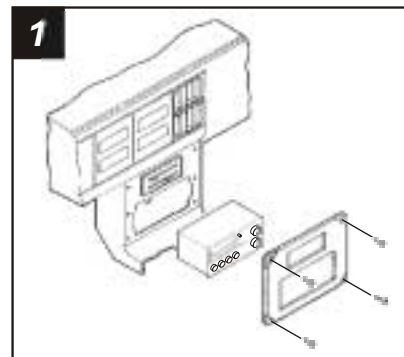

Disconnect the negative battery terminal to prevent an accidental short circuit. Remove (4) star-drive screws from the dash trim bezel and remove the bezel. Remove (4) screws securing the factory head unit and disconnect the wiring.

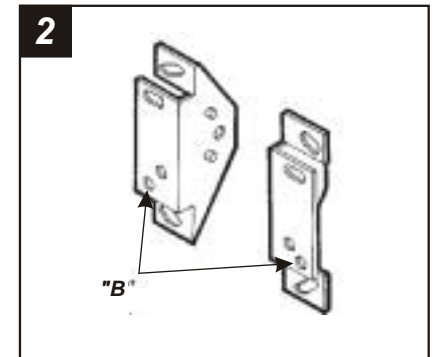

Cut and remove all mounting tabs on **Bracket #2** EXCEPT those tabs with holes "B". The mounting tabs can be identified by the stamped letter on the back of each tab. *Skip to the Installation Instructions for ALL VEHICLES on Page #34.*

CHEVROLET Camaro 1997-99

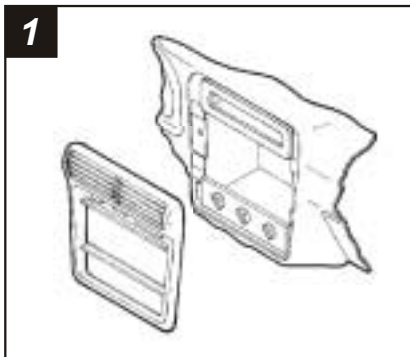

1 Disconnect the negative battery terminal to prevent an accidental short circuit. Unclip the radio trim bezel and remove. Remove (2) 7mm hex-head screws securing the factory head unit and disconnect the wiring.

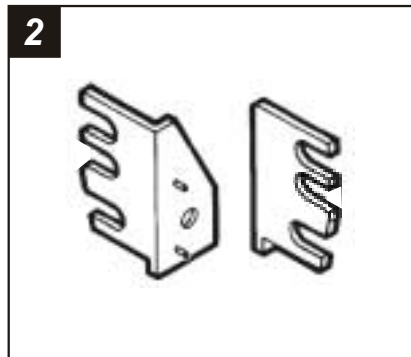

2 Locate **Bracket Set #10**. Skip to the *Installation Instructions for ALL VEHICLES on Page #34*.

OLDSMOBILE Cutlass Supreme 1984-88

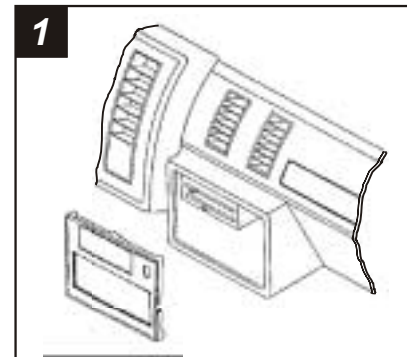

1 Disconnect the negative battery terminal to prevent an accidental short circuit. Remove the cigarette lighter and radio knobs and unsnap the radio trim bezel. Remove (1) screw from the right side of the ashtray housing.

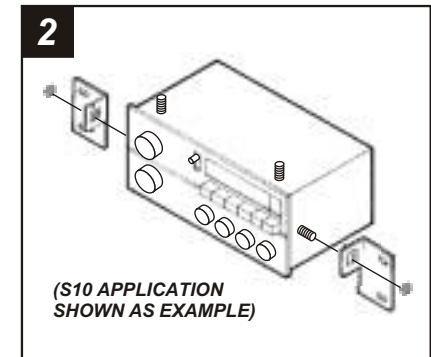

2 Remove the hardware securing the factory mounting brackets to the factory head unit. Remove and retain the brackets. Skip to the *Installation Instructions for ALL VEHICLES on Page #34*.

CHEVROLET Caprice / Impala SS 1994-96

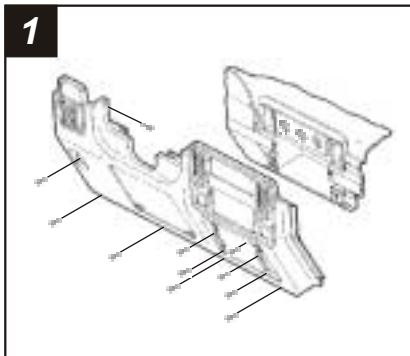

1 Disconnect the negative battery terminal to prevent an accidental short circuit. Remove (5) hex-head screws from the ashtray cavity. Remove (4) hex-head screws from the base of the dash trim bezel. Unsnap the fuse box cover and remove (1) hex-head screw exposed. Remove (2) hex-head screws above the instrument cluster. Place the gear selector in "D1". Pull out on the cluster trim and remove. Remove (1) hex-head screw exposed on the left edge of the dash trim bezel. Unclip the dash trim bezel (including the radio trim bezel) and remove.

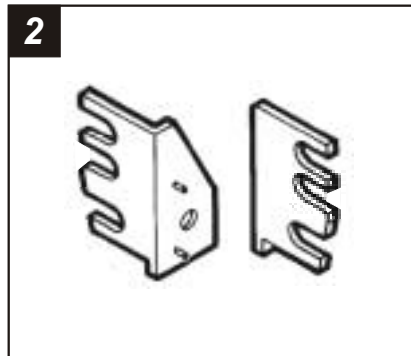

2 Locate **Bracket Set #10**. Skip to the *Installation Instructions for ALL VEHICLES on Page #34*.

OLDSMOBILE Omega 1983-84

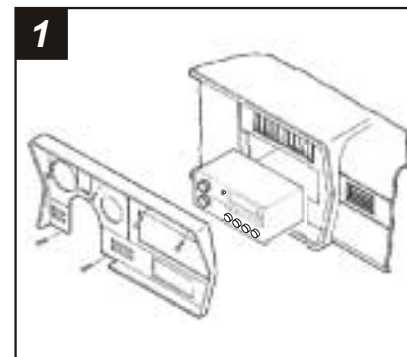

1 Disconnect the negative battery terminal to prevent an accidental short circuit. Remove (4) hex-head washer screws from the steering column trim panel, pull down on the rear edge of the panel and remove. Remove (4) Phillips screws from the top edge of the dash trim bezel. Remove (2) hex-head washer screws from the bottom of the dash trim bezel and remove the bezel.

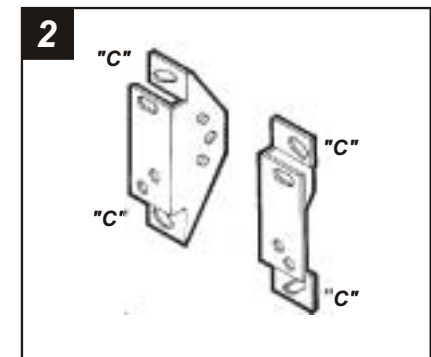

2 Cut and remove all mounting tabs on **Bracket #2 EXCEPT** tabs "C". The mounting tabs can be identified by the stamped letter on the back of each tab. Skip to the *Installation Instructions for ALL VEHICLES on Page #34*.

OLDSMOBILE Cutlass Calais 1984-91

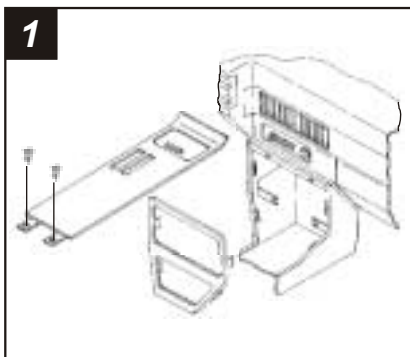

1
Disconnect the negative battery terminal to prevent an accidental short circuit. Remove the console/glove box assembly and (3) screws below the box. Lift up the parking brake trim and remove (2) screws from the gear shifter trim. Remove the ashtray from the gear shifter area and (2) 7mm screws exposed. Using a screwdriver, depress the retainer tabs on the dash ashtray, pull the ashtray out and remove (2) 7mm hex-head screws from the ashtray bracket.

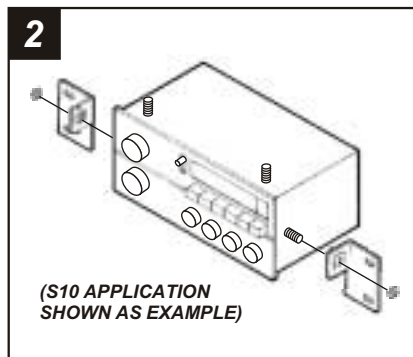

2
Remove the hardware securing the factory mounting brackets to the factory head unit. Remove and retain the brackets. *Skip to the Installation Instructions for ALL VEHICLES on Page #34.*

OLDSMOBILE Cutlass Ciera 1982-96

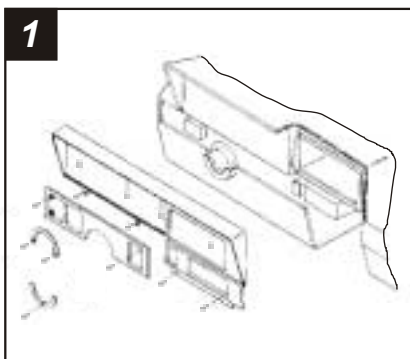

1
Disconnect the negative battery terminal to prevent an accidental short circuit. Remove the ashtray and (2) screws from the ashtray location. Remove (1) screw below and (2) screws above the steering column. Pry the a/c vents out and remove the screws exposed in the vent cavities. Remove (6) screws from the edge of the dash trim bezel and remove the bezel.

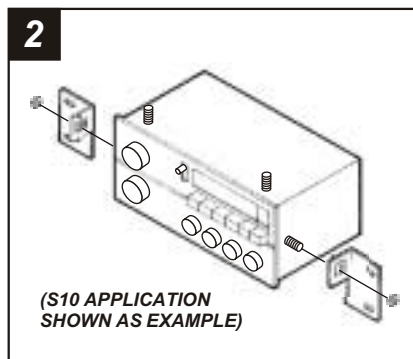

2
Remove the hardware securing the factory mounting brackets to the factory head unit. Remove and retain the brackets. *Skip to the Installation Instructions for ALL VEHICLES on Page #34.*

CHEVROLET Cavalier 1982-90 / Cadillac Cimarron 1982-88 PONTIAC Sunbird J-2000 1982-88

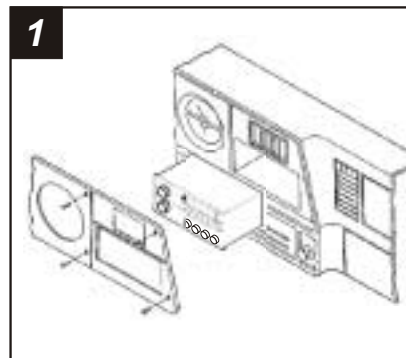

1
Disconnect the negative battery terminal to prevent an accidental short circuit. Remove (6) star-drive screws from the dash trim bezel and remove the bezel. Remove (2) screws from the factory head unit and disconnect the wiring.

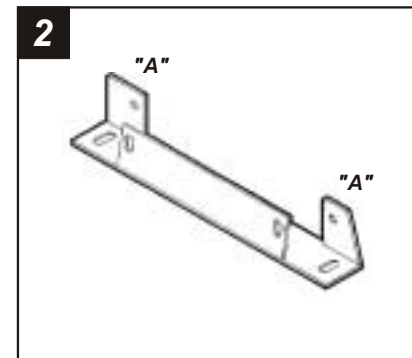

2
Cut and remove all mounting tabs on **Bracket #4** EXCEPT tabs "A". The mounting tabs can be identified by the stamped letter on the back of each tab. *Skip to the Installation Instructions for ALL VEHICLES on Page #34.*

CHEVROLET Cavalier 1991-94

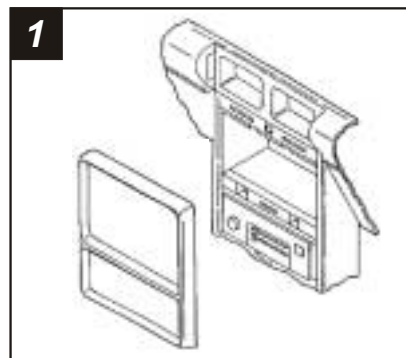

1
Disconnect the negative battery terminal to prevent an accidental short circuit. Using a panel removal tool, carefully pry out on the dash trim bezel and remove. Remove (2) screws securing the factory head unit and disconnect the wiring.

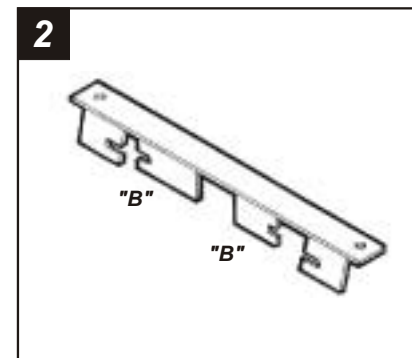

2
Cut and remove all mounting tabs on **Bracket #3** EXCEPT tabs "B". The mounting tabs can be identified by the stamped letter on the back of each tab. *Skip to the Installation Instructions for ALL VEHICLES on Page #34.*

CHEVROLET Cavalier 1995-99

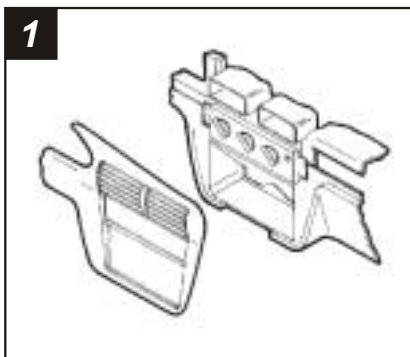

1
Disconnect the negative battery terminal to prevent an accidental short circuit. Open drivers door and remove fuse panel on end of dash. Open passenger door and remove panel on end of dash. Remove (1) phillips screw from each side, now exposed. Remove (3) 7mm hex-head screws from the top of the glove box liner. Remove (2) 7mm hex-head screws from the top-left corner of the glove box cavity. Remove (1) Phillips screw from the defroster duct. Remove the duct work and (1) Phillips screw exposed. Remove the dash pad and (3) Phillips screws exposed at the top of the radio trim bezel.

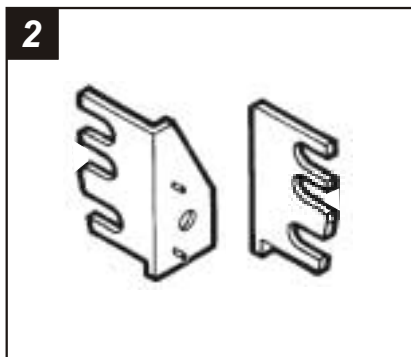

2
Locate **Bracket Set #10**. Skip to the *Installation Instructions for ALL VEHICLES* on Page #34.

OLDSMOBILE 98 1984-90 / Delta 88 1986-88

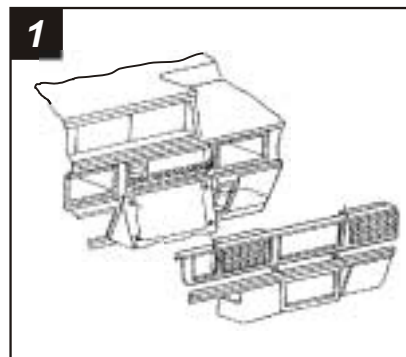

1
Disconnect the negative battery terminal to prevent an accidental short circuit. Place the gear shifter in low and remove the rubber trim boot from the steering column. Remove (2) Phillips screws from the radio trim bezel. Unhook the ashtray/light wiring terminal and remove the trim bezel.

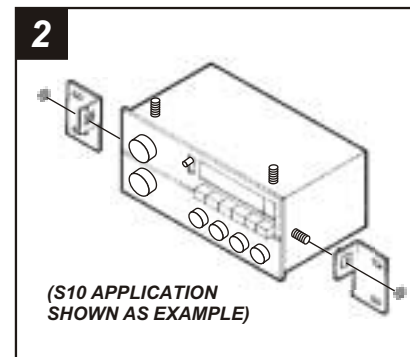

2
Remove the hardware securing the factory mounting brackets to the factory head unit. Remove and retain the brackets. Skip to the *Installation Instructions for ALL VEHICLES* on Page #34.

CHEVROLET Celebrity 1982-83

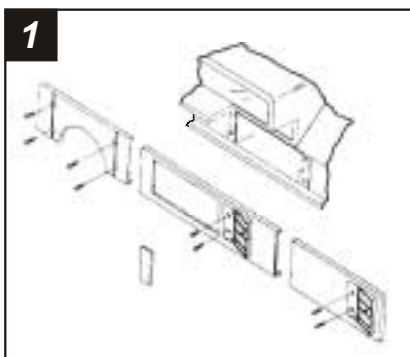

1
Disconnect the negative battery terminal to prevent an accidental short circuit. Remove the plastic plate next to each a/c vent and remove (2) screws exposed. Remove (4) screws surrounding the steering column. Depress the light control knob spring, remove the knob and lift the bezel off.

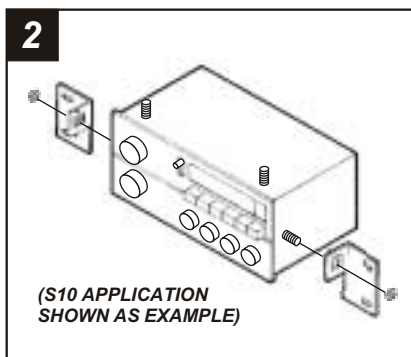

2
Remove the hardware securing the factory mounting brackets to the factory head unit. Remove and retain the brackets. Skip to the *Installation Instructions for ALL VEHICLES* on Page #34.

OLDSMOBILE Achieva 1992-95

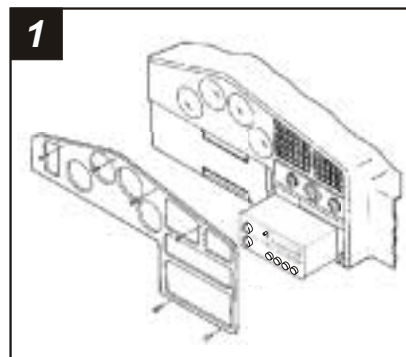

1
Disconnect the negative battery terminal to prevent an accidental short circuit. Remove (4) screws from the top edge of the dash trim bezel. Remove (2) screws from the bottom edge of the bezel. Unsnap the a/c ducts, disconnect the light switch and remove the bezel.

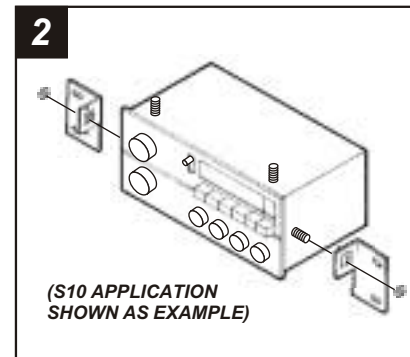

2
Remove the hardware securing the factory mounting brackets to the factory head unit. Remove and retain the brackets. Skip to the *Installation Instructions for ALL VEHICLES* on Page #34.

CHEVROLET Van (full size) 1988-95 GMC Van (full size) 1988-95

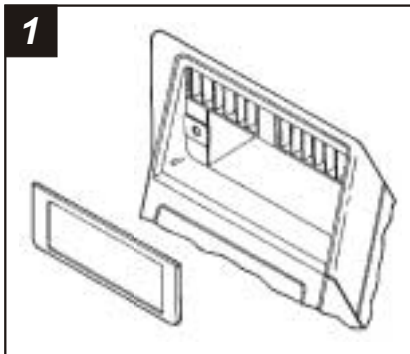

1
Disconnect the negative battery terminal to prevent an accidental short circuit. Carefully unsnap the radio trim bezel and remove. Remove (2) screws securing the factory head unit and disconnect the wiring.

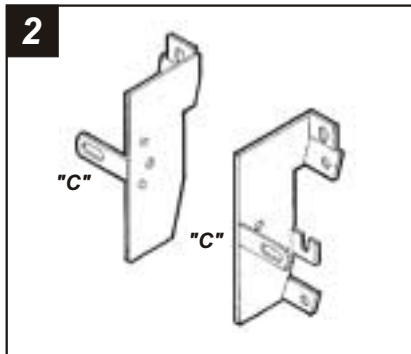

2
Cut and remove all mounting tabs on **Bracket #1** EXCEPT tabs "C". The mounting tabs can be identified by the stamped letter on the back of each tab. Skip to the *Installation Instructions for ALL VEHICLES* on Page #34.

CHEVROLET Venture / OLDSMOBILE Silhouette 1997-99 PONTIAC Montana 1999 / TransSport 1997-98

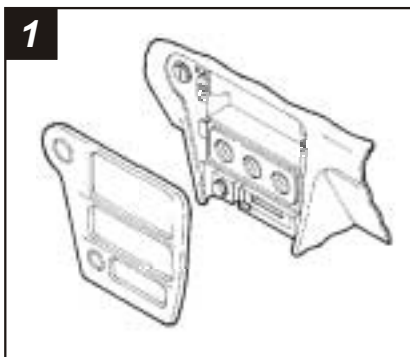

1
Disconnect the negative battery terminal to prevent an accidental short circuit. Remove the ashtray and (1) Phillips screw exposed in the ashtray cavity. Remove (1) Phillips screw from the cigarette lighter compartment. Remove (2) Phillips screws securing the factory head unit and disconnect the wiring.

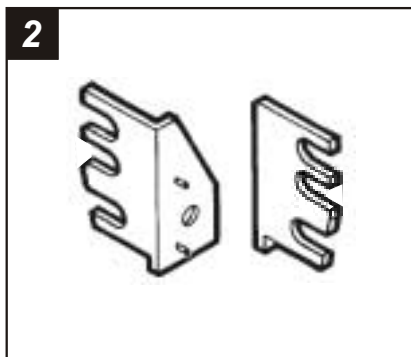

2
Locate **Bracket Set #10**. Skip to the *Installation Instructions for ALL VEHICLES* on Page #34.

CHEVROLET Celebrity 1984-87

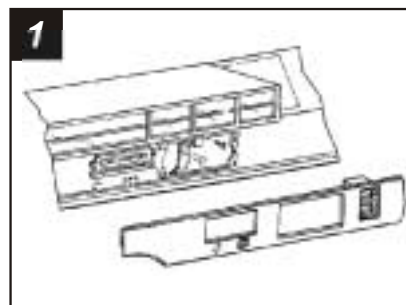

1
Disconnect the negative battery terminal to prevent an accidental short circuit. Remove the glove box compartment by depressing the clip on the bottom of the glove box liner and removing (6) nuts exposed above the opening. Remove (6) Phillips screws below the steering column. Remove the headlight knob by depressing the clip on the back of the knob and removing the nut. Remove the cigarette lighter and disconnect the wiring. Grasp the lighter socket, unscrew the brass nut on the back of the lighter and remove the socket. Remove the dash trim bezel and disconnect the wiring.

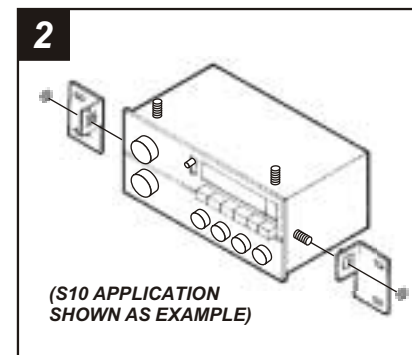

2
Remove the hardware securing the factory mounting brackets to the factory head unit. Remove and retain the brackets. Skip to the *Installation Instructions for ALL VEHICLES* on Page #34.

CHEVROLET Citation II 1985

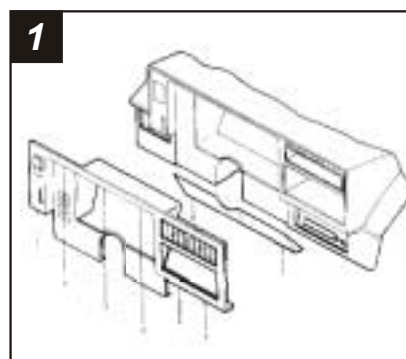

1
Disconnect the negative battery terminal to prevent an accidental short circuit. Remove (2) screws from the bottom steering column trim panel and remove. Remove (6) screws from the dash trim bezel, disconnect the wiring and remove.

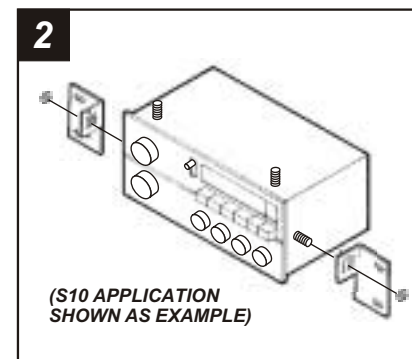

2
Remove the hardware securing the factory mounting brackets to the factory head unit. Remove and retain the brackets. Skip to the *Installation Instructions for ALL VEHICLES* on Page #34.

CHEVROLET Corvette 1984-89

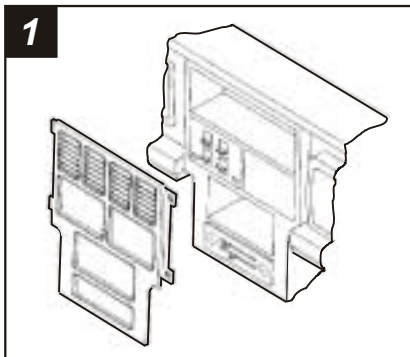

1
Disconnect the negative battery terminal to prevent an accidental short circuit. Remove (7) screws from the dash trim bezel. Move the gear shifter to the lowest position. Pull the right edge of the bezel forward, unhook the left side and remove.

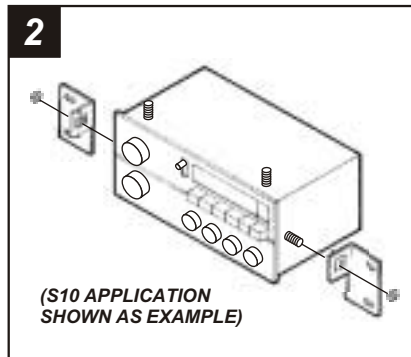

2
Remove the hardware securing the factory mounting brackets to the factory head unit. Remove and retain the brackets. *Skip to the Installation Instructions for ALL VEHICLES on Page #34.*

CHEVROLET Corvette 1997-02

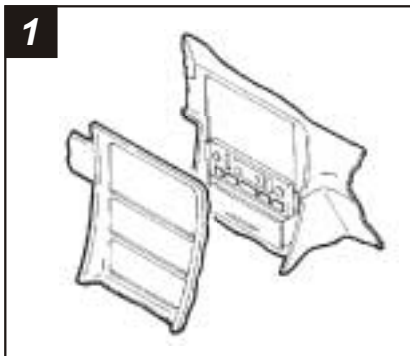

1
Disconnect the negative battery terminal to prevent an accidental short circuit. Pry out on the ride control switch and disconnect the wiring. Unsnap the switch trim and remove (2) 10mm hex-head bolts exposed. Open the center console door, remove (4) screws from the inner hinge and remove the door. Open the ashtray and remove (1) screw exposed. Remove the ashtray and (1) screw exposed. Unclip the small grille to the left of the ignition switch and remove (1) screw exposed. Unclip the base of the radio trim bezel and remove.

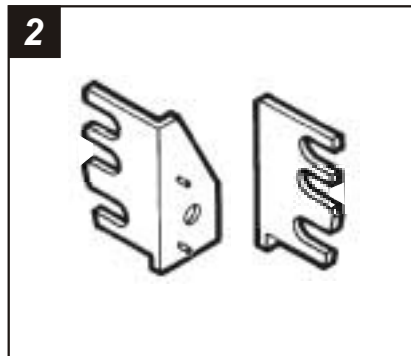

2
Locate **Bracket Set #10**. *Skip to the Installation Instructions for ALL VEHICLES on Page #34.*

CHEVROLET S10 Pickup 1982-85 / S10 Blazer 1982-85 GMC S15 Pickup 1982-85 / S15 Jimmy 1982-85

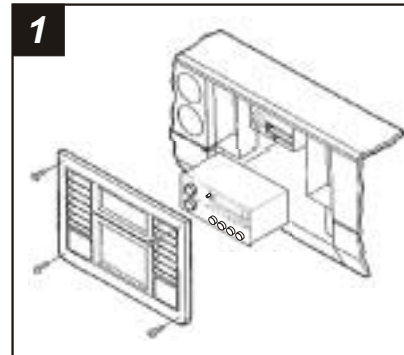

1
Disconnect the negative battery terminal to prevent an accidental short circuit. Remove (4) star-drive screws from the corners of the dash trim bezel. Remove (1) star-drive screw from the lower-right corner of the instrument cluster panel and remove the dash trim bezel.

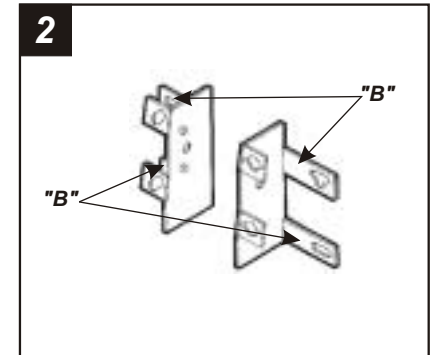

2
Cut and remove all mounting tabs on **Bracket #1** EXCEPT tabs "**C**". The mounting tabs can be identified by the stamped letter on the back of each tab. *Skip to the Installation Instructions for ALL VEHICLES on Page #34.*

CHEVROLET S10 Pickup 1986-93 / S10 Blazer 1986-94 GMC S15 Pickup 1986-93 / S15 Jimmy 1986-94 OLDSMOBILE Bravada 1991-94

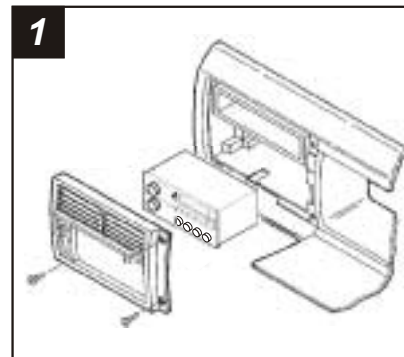

1
Disconnect the negative battery terminal to prevent an accidental short circuit. Remove the ashtray and (1) screw inside the ashtray cavity. Open the glove box and remove (2) screws exposed on the edge of the dash trim bezel.

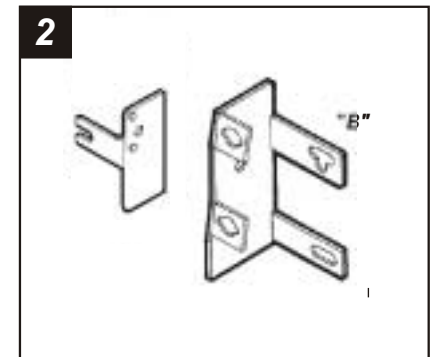

2
Locate **Bracket #(L) S-10** and the right Bracket from **Bracket Set #5**. Cut and remove all mounting tabs on the right Bracket EXCEPT top tab "**B**". The mounting tabs can be identified by the stamped letter on the back of each tab. *Skip to the Installation Instructions for ALL VEHICLES on Page #34.*

CHEVROLET Malibu 1997-99

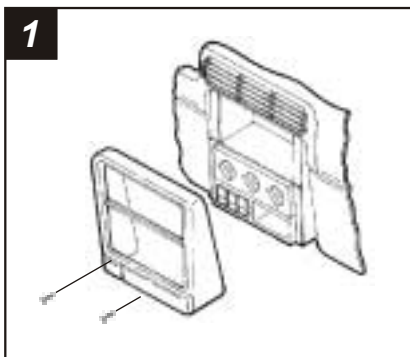

1
Disconnect the negative battery terminal to prevent an accidental short circuit. Unclip the radio trim bezel and remove. Remove (2) 9/32" hex-head screws securing the factory head unit and disconnect the wiring.

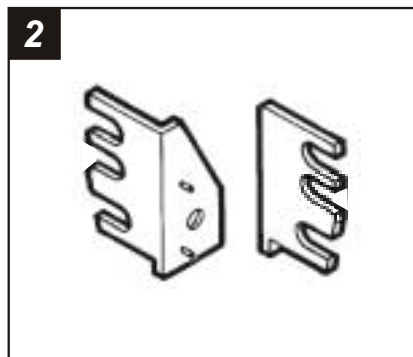

2
Locate **Bracket Set #10**. Skip to the *Installation Instructions for ALL VEHICLES* on Page #34.

CHEVROLET El Camino / Monte Carlo 1985-88

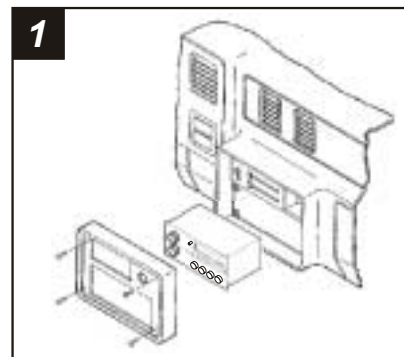

1
Disconnect the negative battery terminal to prevent an accidental short circuit. Remove (4) screws from the dash trim bezel. Remove the bezel and disconnect the cigarette lighter wiring.

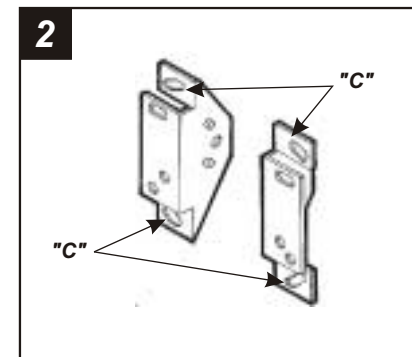

2
Cut and remove all mounting tabs on **Bracket #2** EXCEPT tabs "C". The mounting tabs can be identified by the stamped letter on the back of each tab. Skip to the *Installation Instructions for ALL VEHICLES* on Page #34.

CHEVROLET Nova 1985-88

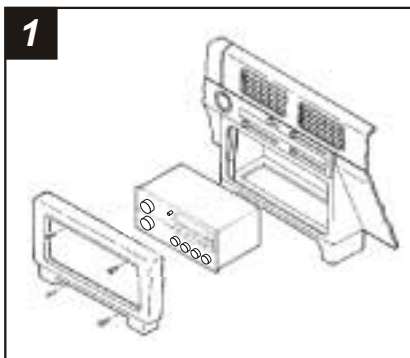

1
Disconnect the negative battery terminal to prevent an accidental short circuit. Remove the ashtray and (2) screws from the ashtray bracket. Remove (2) screws above the radio opening and remove the radio trim bezel.

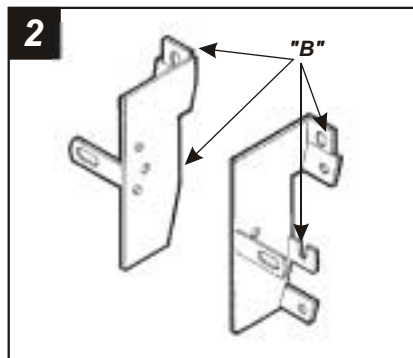

2
Cut and remove all mounting tabs on **Bracket #1** EXCEPT tabs "B". The mounting tabs can be identified by the stamped letter on the back of each tab. Skip to the *Installation Instructions for ALL VEHICLES* on Page #34.

CHEVROLET Express / GMC Savana 1996-00

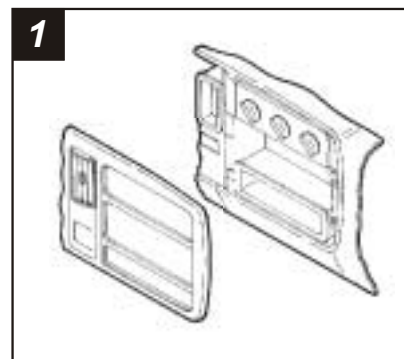

1
Disconnect the negative battery terminal to prevent an accidental short circuit. Unclip the plastic trim piece located below the steering column. Unclip the dash trim bezel. Pull the bezel over the steering column and disconnect the wiring. Using a flat-blade screwdriver, press down on the outside clips of the factory head unit and remove. Skip to the *Installation Instructions for ALL VEHICLES* on Page #2.

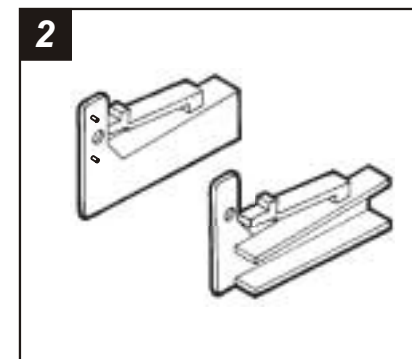

2
Locate **Bracket Set #8**. Skip to the *Installation Instructions for ALL VEHICLES* on Page #34.

CHEVROLET Lumina 1990-94

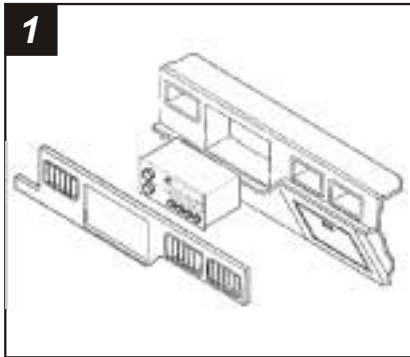

1
Disconnect the negative battery terminal to prevent an accidental short circuit. Remove (2) screws from the lower steering column panel. Pull the panel down to access the bottom portion of the radio trim bezel. Pull the top and bottom edges of the bezel forward and remove.

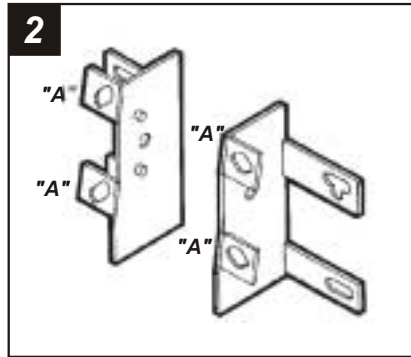

2
Cut and remove all mounting tabs on **Bracket #5** EXCEPT tabs "A". The mounting tabs can be identified by the stamped letter on the back of each tab. Skip to the *Installation Instructions for ALL VEHICLES on Page #34*.

CHEVROLET Lumina APV / OLDSMOBILE Silhouette PONTIAC TransSport 1990-95

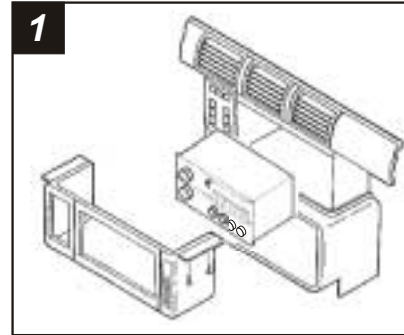

1
Disconnect the negative battery terminal to prevent an accidental short circuit. Remove (2) screws securing the lower steering column panel and remove. Remove (2) screws exposed on the left tab of the radio trim bezel. Open the glove box and remove (2) screws exposed on the right tabs of the radio trim bezel.

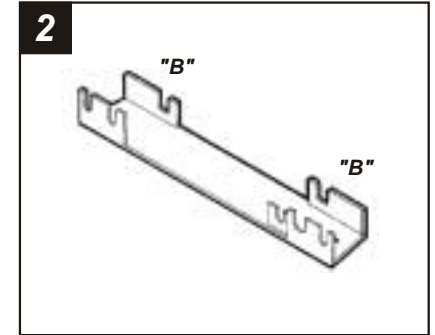

2
Cut and remove all mounting tabs on **Bracket #6** EXCEPT tabs "B". The mounting tabs can be identified by the stamped letter on the back of each tab. Skip to the *Installation Instructions for ALL VEHICLES on Page #34*.

CHEVROLET Lumina / Monte Carlo 1995-99

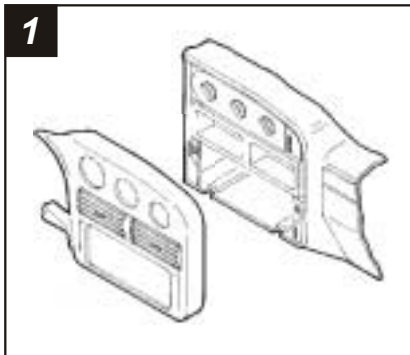

1
Disconnect the negative battery terminal to prevent an accidental short circuit. Unclip the dash trim bezel and remove. (It may be necessary to loosen the knee bolster). Remove (2) 7mm hex-head screws securing the factory head unit and disconnect the wiring.

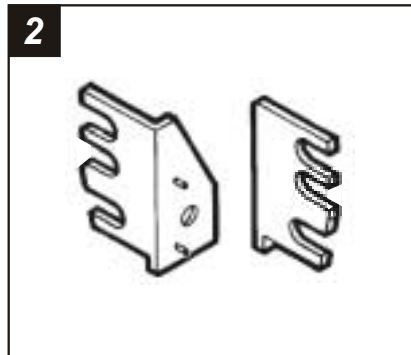

2
Locate **Bracket Set #10**. Skip to the *Installation Instructions for ALL VEHICLES on Page #34*.

CHEVROLET Lumina APV / OLDSMOBILE Silhouette PONTIAC TransSport 1996

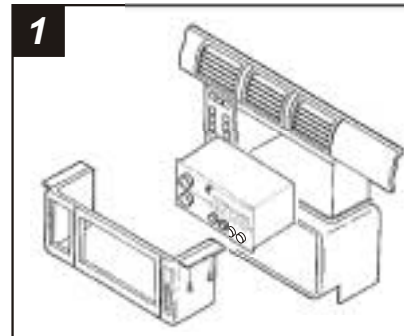

1
Disconnect the negative battery terminal to prevent an accidental short circuit. Remove (1) Phillips screw from each side of the center console. Open the glove box and remove (2) Phillips screws exposed. Remove (2) 7mm hex-head screws and (1) pop-clip from the lower steering column panel, and (2) Phillips screws exposed near the climate controls. Remove (1) 7mm hex-head screw under the glove box. Pull out on the center console and remove.

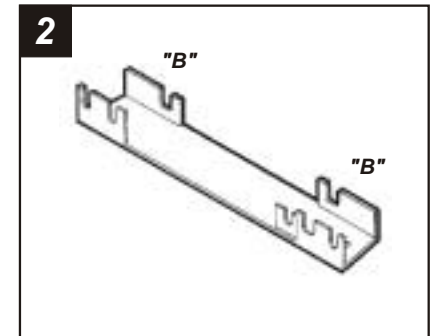

2
Cut and remove all mounting tabs on **Bracket #6** EXCEPT tabs "B". The mounting tabs can be identified by the stamped letter on the back of each tab. Skip to the *Installation Instructions for ALL VEHICLES on Page #34*.