

ALL VEHICLES

1

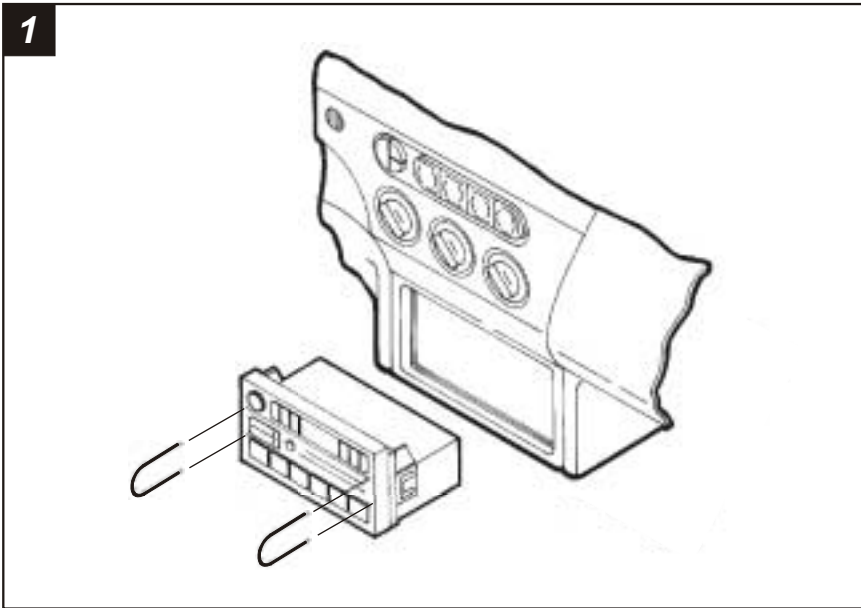

Disconnect the negative battery terminal to prevent an accidental short circuit. Using Metra's **86-5618**, pull the factory head unit from the dash and disconnect the wiring.

2

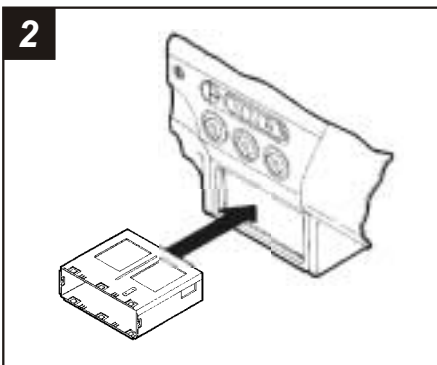

Slide the DIN cage into the top of the dash opening and secure by bending the metal locking tabs down.

3

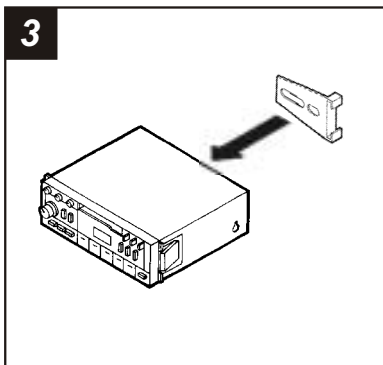

Secure the **Rear Support Bracket** to the back of the aftermarket head unit as shown above.

4

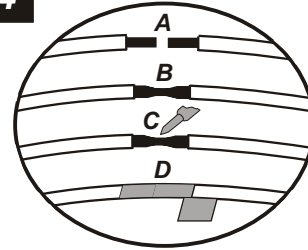

A) Strip wire ends back 1/2"
B) Twist ends together
C) Solder
D) Tape

Locate the factory wiring harness in the dash. Metra recommends using the proper mating adaptor and making connections as shown. (Isolate and individually tape off the ends of any unused wires to prevent electrical short circuit).

5

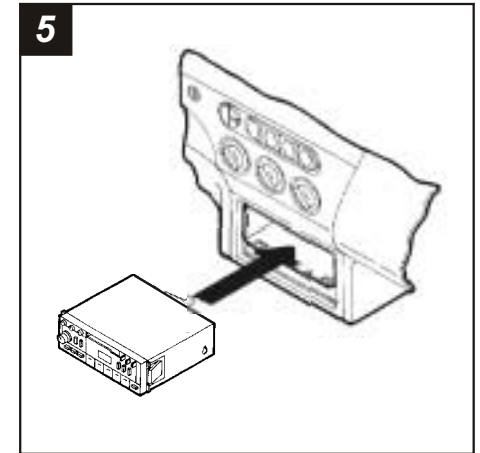

Slide the DIN head unit halfway into the cage. Reach under the cage, rotate the **Rear Support Bracket** down and slide the Bracket onto the rear support shelf in the dash. Slide the head unit the rest of the way into the cage until secure.

6

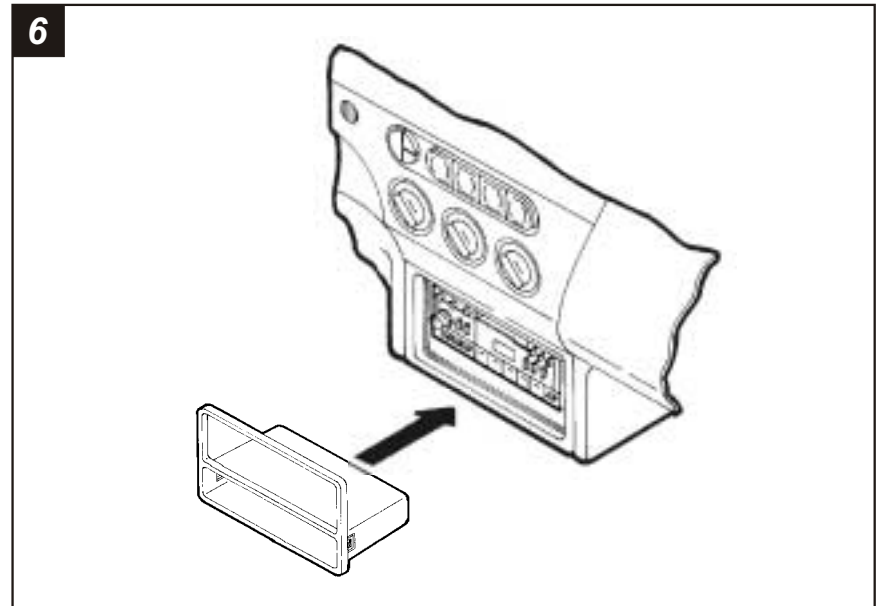

Snap the **Radio Housing** over the mounted head unit. (The snaps on the Radio Housing will snap into the sides of the dash bezel.)

KIT FEATURES

- ▶ Holds 2 CD jewel cases

KIT COMPONENTS

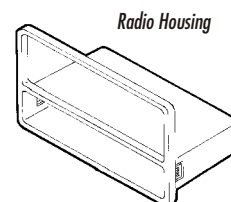

TOOLS REQUIRED



86-5618 - Head unit removal keys

99-5200 INSTALLATION INSTRUCTIONS

APPLICATIONS

CAR	PAGE
FORD	
Focus 2000-03.....	1-2
MERCURY	
Cougar 1999-02.....	1-2

