

LINCOLN Mark VIII 1993-95

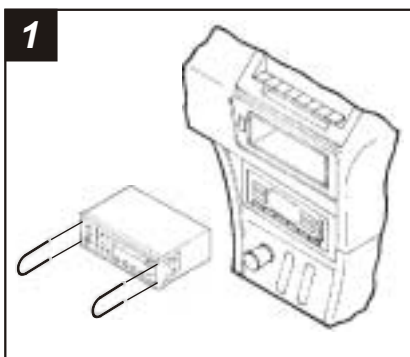

1
Disconnect the negative battery terminal to prevent an accidental short circuit. Using Metra's **86-5618**, pull the factory head unit from the dash and disconnect the wiring.

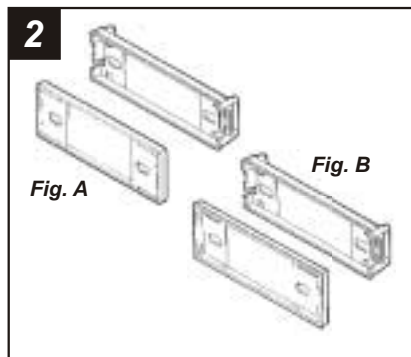

2
Locate the **Snap-in Bracket** and **Rounded Faceplate** (see Fig. A) OR the **Snap-in Bracket** and **Cornered Faceplate** (see Fig. B). Skip to the Installation Instructions for ALL VEHICLES on Page #21.

LINCOLN Town Car 1984-89

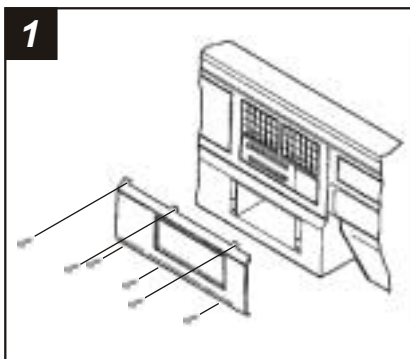

1
Disconnect the negative battery terminal to prevent an accidental short circuit. Remove (3) #8 Phillips screws from the bottom of the radio trim bezel. Unsnap the plastic strip located above the bezel and remove (3) Phillips screws exposed. Gently pull the instrument cluster trim bezel away from the dash and remove the radio trim bezel. Remove (3) hex-head screws securing the factory head unit and disconnect the wiring.

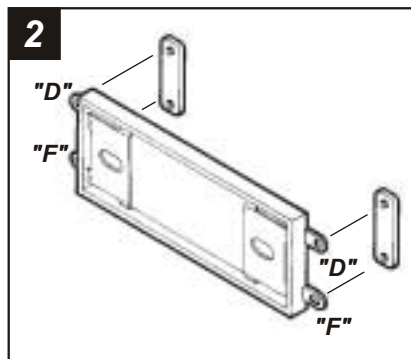

2
Cut and remove all mounting tabs on the **Radio Housing** EXCEPT tabs "D" and "F". The mounting tabs can be identified by the stamped letter on the back of each tab. Locate **Spacer Set #2**. (The Spacers must be placed behind the mounting tabs during installation in step #5). Skip to the Installation Instructions for ALL VEHICLES on Page #22.

FORD Crown Victoria / LTD 1979-90 MERCURY Grand Marquis / Marquis 1979-90

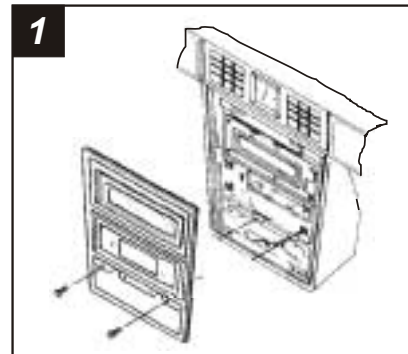

1
Disconnect the negative battery terminal to prevent an accidental short circuit. Open the ashtray and remove (2) Phillips screws securing the dash trim bezel. Remove (4) screws securing the factory head unit and disconnect the wiring.

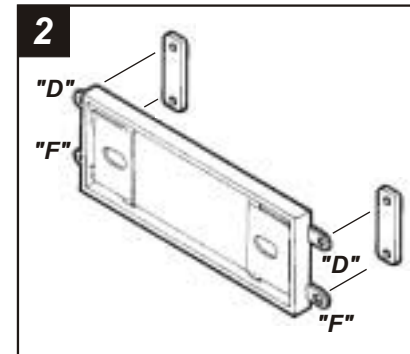

2
Cut and remove all mounting tabs on the **Radio Housing** EXCEPT tabs "D" and "F". The mounting tabs can be identified by the stamped letter on the back of each tab. Locate **Spacer Set #2**. (The Spacers must be placed behind the mounting tabs during installation in step #5). Skip to the Installation Instructions for ALL VEHICLES on Page #22.

FORD Crown Victoria 1991-94 MERCURY Grand Marquis 1991-94

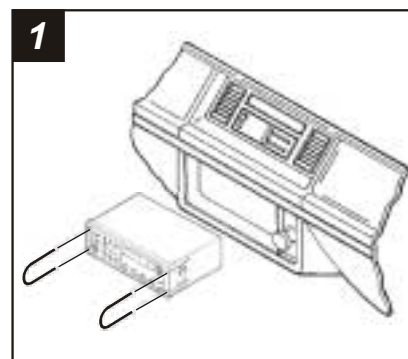

1
Disconnect the negative battery terminal to prevent an accidental short circuit. Using Metra's **86-5618**, pull the factory head unit from the dash and disconnect the wiring.

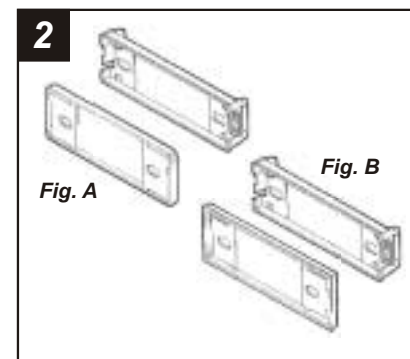

2
Locate the **Snap-in Bracket** and **Rounded Faceplate** (see Fig. A) OR the **Snap-in Bracket** and **Cornered Faceplate** (see Fig. B). Skip to the Installation Instructions for ALL VEHICLES on Page #21.

FORD Econoline 1992-96

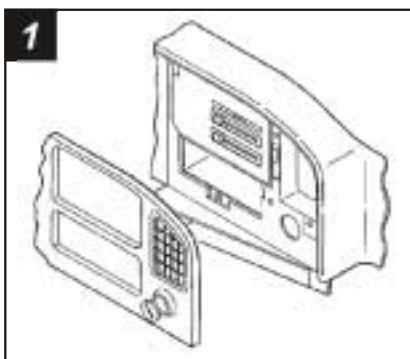

Disconnect the negative battery terminal to prevent an accidental short circuit. Remove the light switch knob and unscrew the surrounding trim. Remove the cupholder and the screws exposed in the cupholder cavity. Unsnap the (2) trim bezel inserts and remove the screws exposed. Remove the lower steering column trim panel and unclip the dash trim bezel. Using Metra's **86-5618**, pull the factory head unit from the dash and disconnect the wiring.

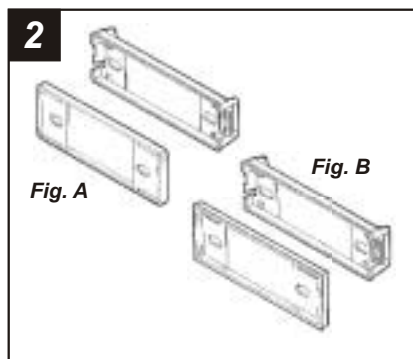

Locate the **Snap-in Bracket** and **Rounded Faceplate** (see Fig. A) OR the **Snap-in Bracket** and **Cornered Faceplate** (see Fig. B). Skip to the *Installation Instructions for ALL VEHICLES on Page #21*.

LINCOLN Continental 1985-87

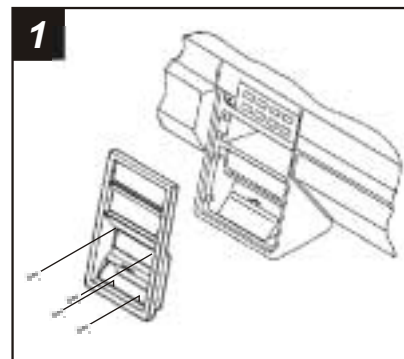

Disconnect the negative battery terminal to prevent an accidental short circuit. Remove (2) #8 Phillips screws below the radio opening. Open the ashtray and remove (2) #8 Phillips screws exposed (it is NOT necessary to remove the center screw). Unclip and remove the dash trim bezel. Remove (4) hex-head screws securing the factory head unit and disconnect the wiring.

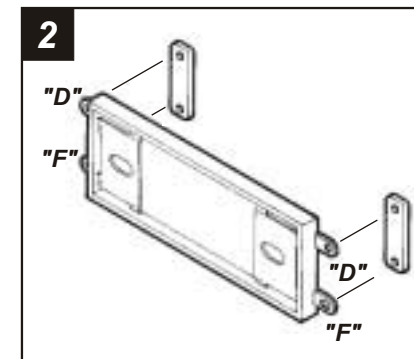

Cut and remove all mounting tabs on the **Radio Housing** EXCEPT tabs "D" and "F". The mounting tabs can be identified by the stamped letter on the back of each tab. Locate **Spacer Set #2**. (The Spacers must be placed behind the mounting tabs during installation in step #5). Skip to the *Installation Instructions for ALL VEHICLES on Page #22*.

FORD Escort / MERCURY Tracer 1991-96

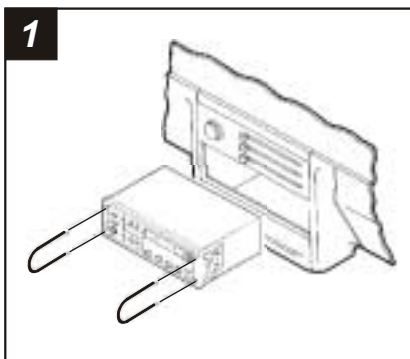

Disconnect the negative battery terminal to prevent an accidental short circuit. Using Metra's **86-5618**, pull the factory head unit from the dash and disconnect the wiring.

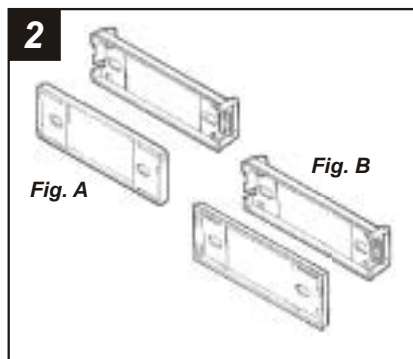

Locate the **Snap-in Bracket** and **Rounded Faceplate** (see Fig. A) OR the **Snap-in Bracket** and **Cornered Faceplate** (see Fig. B). Skip to the *Installation Instructions for ALL VEHICLES on Page #21*.

LINCOLN Mark VII 1984-89

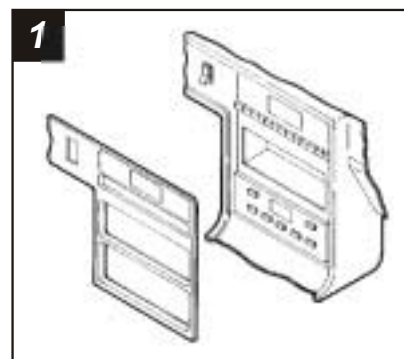

Disconnect the negative battery terminal to prevent an accidental short circuit. Gently pry out on the dash trim bezel and remove. Remove (4) 5mm hex-head sheet metal screws securing the factory head unit and disconnect the wiring.

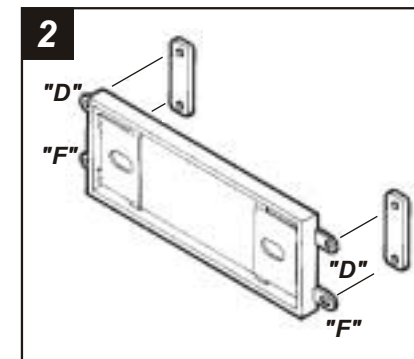

Cut and remove all mounting tabs on the **Radio Housing** EXCEPT tabs "D" and "F". The mounting tabs can be identified by the stamped letter on the back of each tab. Locate **Spacer Set #2**. (The Spacers must be placed behind the mounting tabs during installation in step #5). Skip to the *Installation Instructions for ALL VEHICLES on Page #22*.

JEEP Wrangler 1986-96

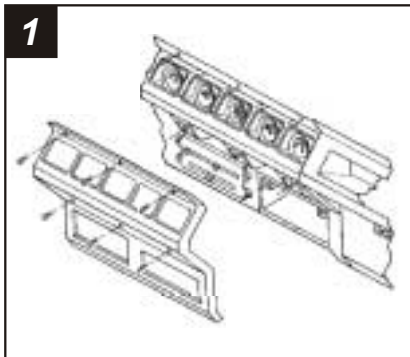

1
Disconnect the negative battery terminal to prevent an accidental short circuit. Remove (6) Phillips screws from the face of the dash trim bezel. Remove the bezel. Remove (2) screws securing the factory head unit and disconnect the wiring.

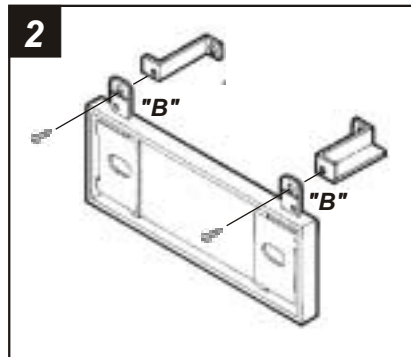

2
Cut and remove all mounting tabs on the **Radio Housing** EXCEPT tabs "B". The mounting tabs can be identified by the stamped letter on the back of each tab. Mount **Bracket Set #1** to the back of the mounting tabs with (2) #8 x 1" Phillips screws supplied. Skip to the Installation Instructions for ALL VEHICLES on Page #22.

FORD Escort / MERCURY Lynx 1985-90

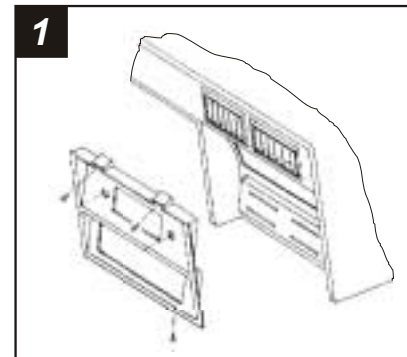

1
Disconnect the negative battery terminal to prevent an accidental short circuit. Remove (4) screws from the top edge of the dash trim bezel. Remove (2) screws from the bottom edge of the dash trim bezel. Remove the climate control knobs and remove the bezel. Remove (4) hex-head screws securing the factory head unit and disconnect the wiring.

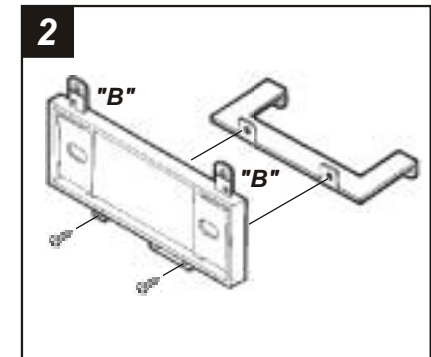

2
Cut and remove all mounting tabs on the **Radio Housing** EXCEPT tabs "B". The mounting tabs can be identified by the stamped letter on the back of each tab. Mount **Bracket #2** to the bottom of the Housing with (2) #8 x 1" Phillips Screws supplied. Skip to the Installation Instructions for ALL VEHICLES on Page #22.

LINCOLN Continental 1988-94 / Mark VII 1990-92 Town Car 1990-94

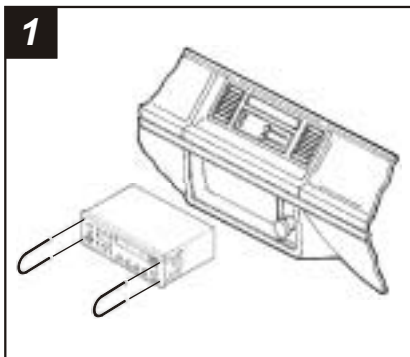

1
Disconnect the negative battery terminal to prevent an accidental short circuit. Using Metra's 86-5618, pull the factory head unit from the dash and disconnect the wiring.

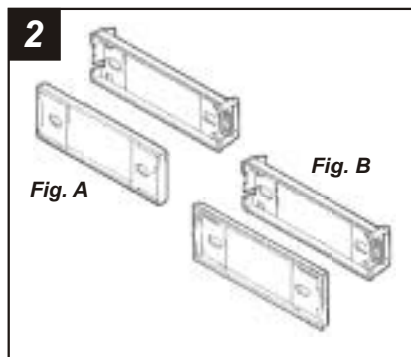

2
Locate the **Snap-in Bracket** and **Rounded Faceplate** (see Fig. A) OR the **Snap-in Bracket** and **Cornered Faceplate** (see Fig. B). Skip to the Installation Instructions for ALL VEHICLES on Page #21.

FORD F-Series Pickup / Bronco 1992-96

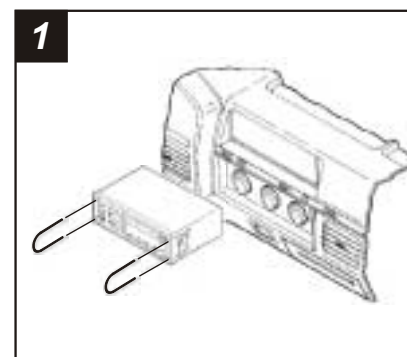

1
Disconnect the negative battery terminal to prevent an accidental short circuit. Using Metra's 86-5618, pull the factory head unit from the dash and disconnect the wiring.

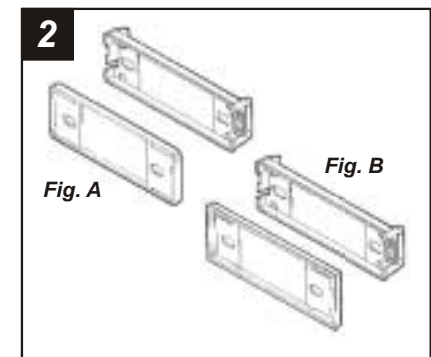

2
Locate the **Snap-in Bracket** and **Rounded Faceplate** (see Fig. A) OR the **Snap-in Bracket** and **Cornered Faceplate** (see Fig. B). Skip to the Installation Instructions for ALL VEHICLES on Page #21.

FORD Festiva 1988-93

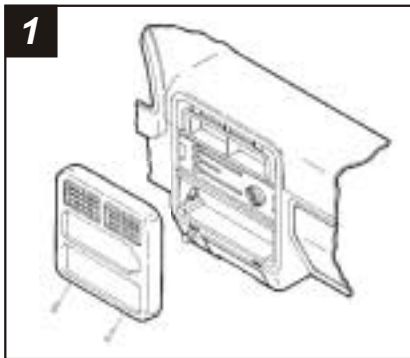

1 Disconnect the negative battery terminal to prevent an accidental short circuit. Remove (4) Phillips screws from the bottom of the dash trim bezel. Remove the bezel. Remove (2) screws securing the factory head unit and disconnect the wiring.

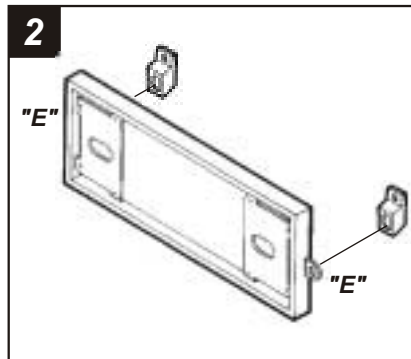

2 Cut and remove all mounting tabs on the **Radio Housing** EXCEPT tabs "E". The mounting tabs can be identified by the stamped letter on the back of each tab. Locate **Spacer Set #1**. (The Spacers must be placed behind the mounting tabs during installation in step #5). *Skip to the Installation Instructions for ALL VEHICLES on Page #22.*

FORD Mustang 1994-00

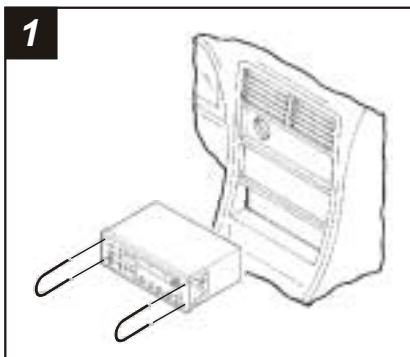

1 Disconnect the negative battery terminal to prevent an accidental short circuit. Using Metra's **86-5618**, pull the factory head unit from the dash and disconnect the wiring.

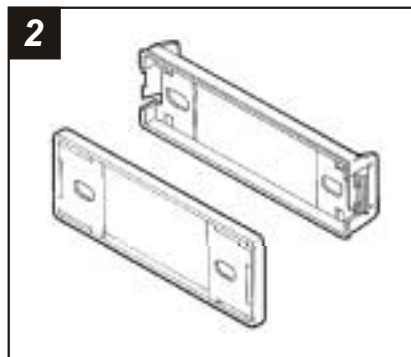

2 Locate the **Snap-in Bracket** and **Rounded Faceplate**. *Skip to the Installation Instructions for ALL VEHICLES on Page #21.*

JEEP Cherokee 1996

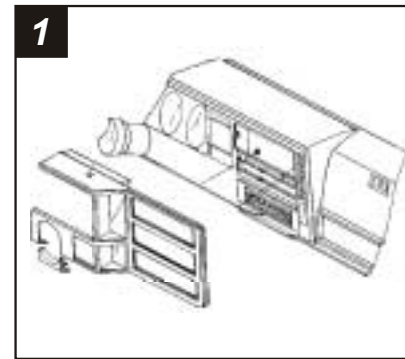

1 Disconnect the negative battery terminal to prevent an accidental short circuit. Remove (3) torx-head screws from the steering column trim panels. Unscrew the tilt steering lever and unsnap the trim panels. Remove (4) screws from the dash trim bezel and remove the bezel. Remove (2) screws securing the factory head unit and disconnect the wiring.

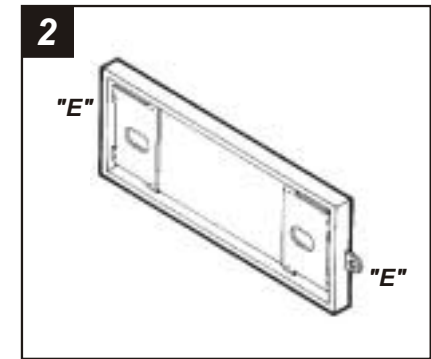

2 Cut and remove all mounting tabs on the **Radio Housing** EXCEPT tabs "E". The mounting tabs can be identified by the stamped letter on the back of each tab. *Skip to the Installation Instructions for ALL VEHICLES on Page #22.*

JEEP Grand Wagoneer 1987-95

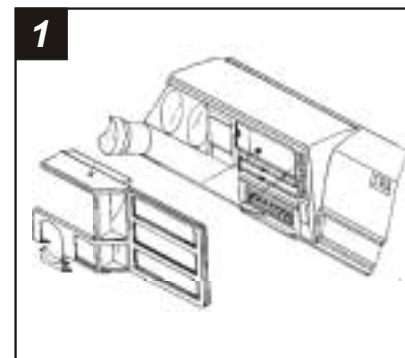

1 Disconnect the negative battery terminal to prevent an accidental short circuit. Gently unclip the dash trim bezel. Remove (2) screws securing the factory head unit and disconnect the wiring.

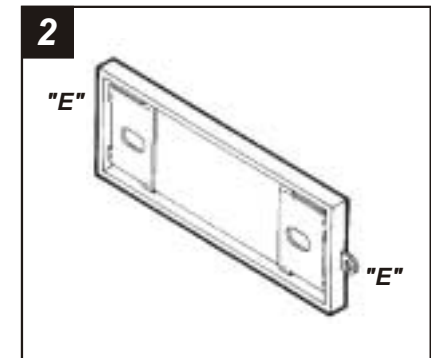

2 Cut and remove all mounting tabs on the **Radio Housing** EXCEPT tabs "E". The mounting tabs can be identified by the stamped letter on the back of each tab. *Skip to the Installation Instructions for ALL VEHICLES on Page #22.*

FORD Windstar 1995-98

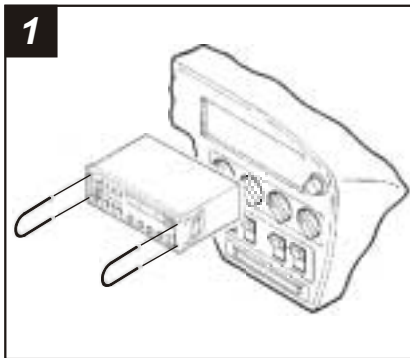

1
Disconnect the negative battery terminal to prevent an accidental short circuit. Using Metra's **86-5618**, pull the factory head unit from the dash and disconnect the wiring.

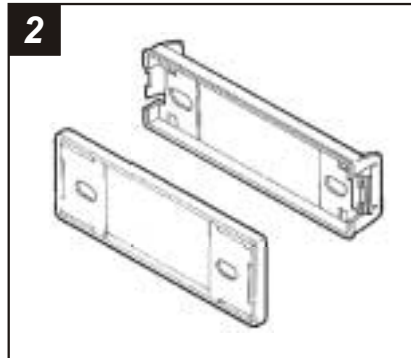

2
Locate the **Snap-in Bracket** and **Rounded Faceplate**. Skip to the *Installation Instructions for ALL VEHICLES on Page #21*.

FORD Probe 1993-97

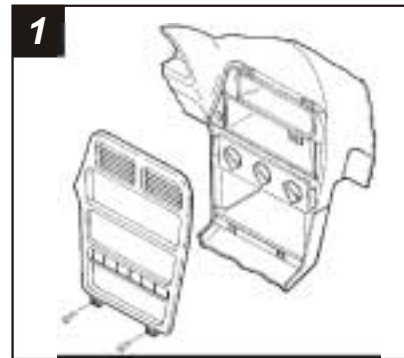

1
Disconnect the negative battery terminal to prevent an accidental short circuit. Remove (2) screws from the base of the dash trim bezel. Unclip and remove the bezel. Using Metra's **86-5618**, pull the factory head unit from the dash and disconnect the wiring.

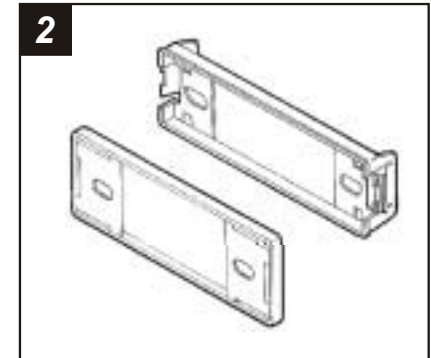

2
Locate the **Snap-in Bracket** and **Rounded Faceplate**. Skip to the *Installation Instructions for ALL VEHICLES on Page #21*.

JEEP Cherokee 1984-95 / Comanche 1986-92 Wagoneer 1984-96

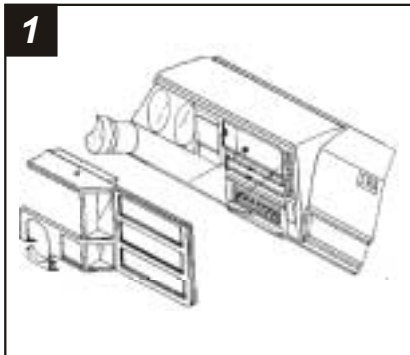

1
Disconnect the negative battery terminal to prevent an accidental short circuit. Unsnap the steering column trim panel and remove. Remove (4) screws from the dash trim bezel and remove the bezel. Remove (2) screws securing the factory head unit and disconnect the wiring.

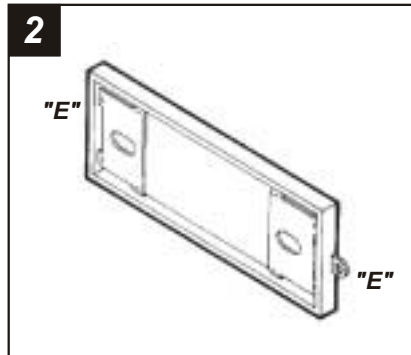

2
Cut and remove all mounting tabs on the **Radio Housing** EXCEPT tabs "E". The mounting tabs can be identified by the stamped letter on the back of each tab. Skip to the *Installation Instructions for ALL VEHICLES on Page #22*.

FORD Taurus / MERCURY Sable 1990-95

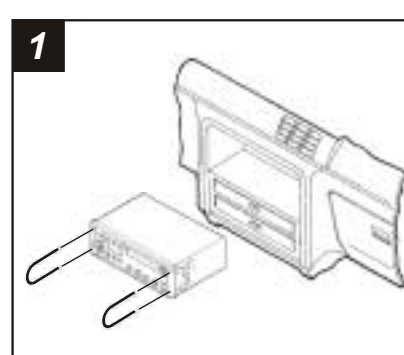

1
Disconnect the negative battery terminal to prevent an accidental short circuit. Using Metra's **86-5618**, pull the factory head unit from the dash and disconnect the wiring.

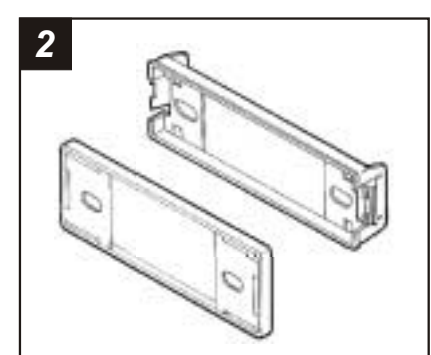

2
Locate the **Snap-in Bracket** and **Rounded Faceplate**. Skip to the *Installation Instructions for ALL VEHICLES on Page #21*.

FORD Taurus / MERCURY Sable 1986-89

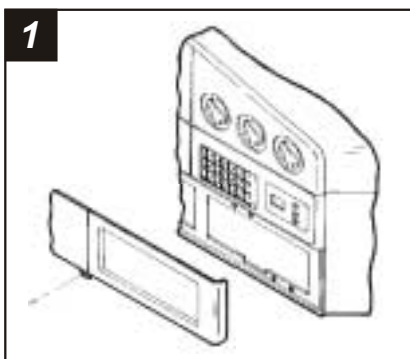

1 Disconnect the negative battery terminal to prevent an accidental short circuit. Remove (1) 7mm hex-head screw from the bottom of the radio trim bezel. Gently unclip the bezel and disconnect the antenna switch power lead. Remove (4) screws securing the factory head unit and disconnect the wiring.

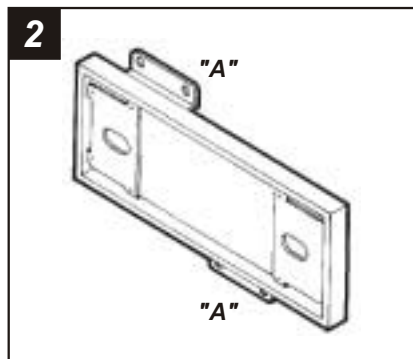

2 Cut and remove all mounting tabs on the Radio Housing EXCEPT tabs "A". The mounting tabs can be identified by the stamped letter on the back of each tab. Skip to the Installation Instructions for ALL VEHICLES on Page #22.

FORD Thunderbird / MERCURY Cougar 1989-97

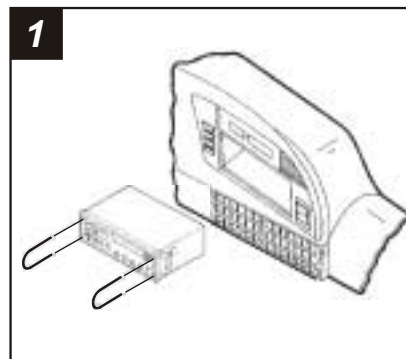

1 Disconnect the negative battery terminal to prevent an accidental short circuit. Using Metra's 86-5618, pull the factory head unit from the dash and disconnect the wiring.

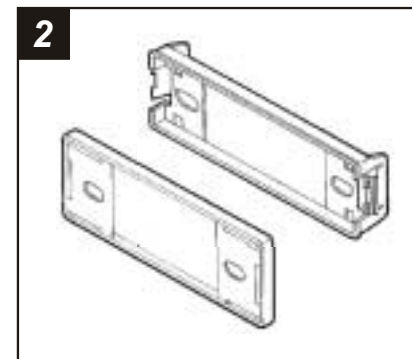

2 Locate the **Snap-in Bracket** and **Rounded Faceplate**. Skip to the Installation Instructions for ALL VEHICLES on Page #21.

FORD Tempo / MERCURY Topaz 1989-94

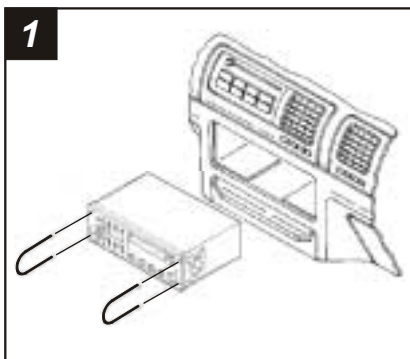

1 Disconnect the negative battery terminal to prevent an accidental short circuit. Using Metra's 86-5618, pull the factory head unit from the dash and disconnect the wiring.

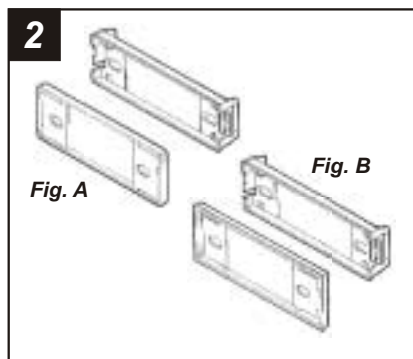

2 Locate the **Snap-in Bracket** and **Rounded Faceplate** (see Fig. A) OR the **Snap-in Bracket** and **Cornered Faceplate** (see Fig. B). Skip to the Installation Instructions for ALL VEHICLES on Page #21.

FORD Thunderbird / MERCURY Cougar 1985-88

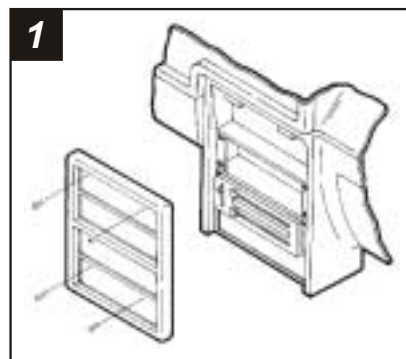

1 Disconnect the negative battery terminal to prevent an accidental short circuit. Remove (2) screws from the top of the dash trim bezel. Open the ashtray and remove (2) screws from the ashtray cavity. Remove (4) screws securing the factory head unit and disconnect the wiring.

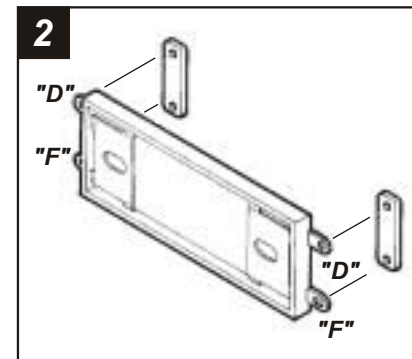

2 Cut and remove all mounting tabs on the **Radio Housing** EXCEPT tabs "D" and "F". The mounting tabs can be identified by the stamped letter on the back of each tab. Locate **Spacer Set #2**. (The Spacers must be placed behind the mounting tabs during installation in step #5). Skip to the Installation Instructions for ALL VEHICLES on Page #22.