

AEROSTAR 1992-97, BRONCO II 1989-90, EXPLORER 1991-94, RANGER 1989-94, CROWN VICTORIA 1991-94, GRAND MARQUIS 1991-94, ECONOLINE 1992-96, ESCORT 1991-96, TRACER (sedan) 1991-96, F-SERIES PICKUP 1992-96, BRONCO 1992-96, TAURUS 1990-95, SABLE 1990-95, TEMPO 1989-94, TOPAZ 1989-94, THUNDERBIRD 1989-97, COUGAR 1989-97, CONTINENTAL 1988-94, MARK VII 1990-92, TOWN CAR 1990-94, MARK VIII 1993-95, ASPIRE, B-SERIES PICKUP, CONTOUR, MYSTIQUE, MUSTANG, PROBE, WINDSTAR, MPV, MX3, MX6, PROTEGE, 626, CAPRI XR2, VILLAGER, QUEST: For DIN units, using the scored lines on the back of the **Faceplate** as a guide, cut and remove the shaft supports and mounting clips. Slide the DIN cage into the dash (through the Faceplate) and secure by bending the metal locking tabs down. Slide the aftermarket head unit into the cage until secure. (see Fig. A). For 2-Shaft units, make wiring connections and slide the aftermarket unit into the dash. Slide the **Shaft Supports** over the radio shafts and position them along the inner lip of the radio opening. Place the aftermarket faceplate against the outer lip of the radio opening and secure with shaft nuts. (see Fig. B)

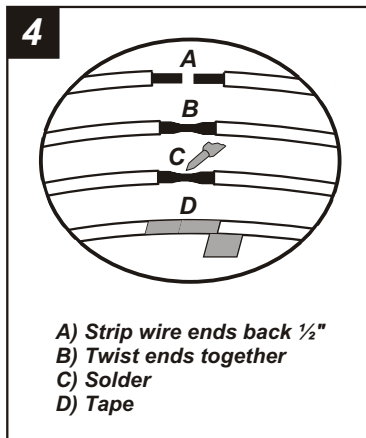

Locate the factory wiring harness in the dash. Metra recommends using the proper mating adaptor and making connections as shown. (Isolate and individually tape off the ends of any unused wires to prevent electrical short circuit).

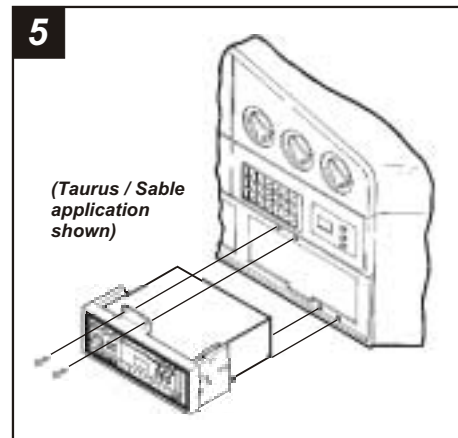

Re-connect the battery terminal and test the unit for proper operation. Mount the head unit/kit assembly to the sub-dash with those screws previously removed.

KIT COMPONENTS

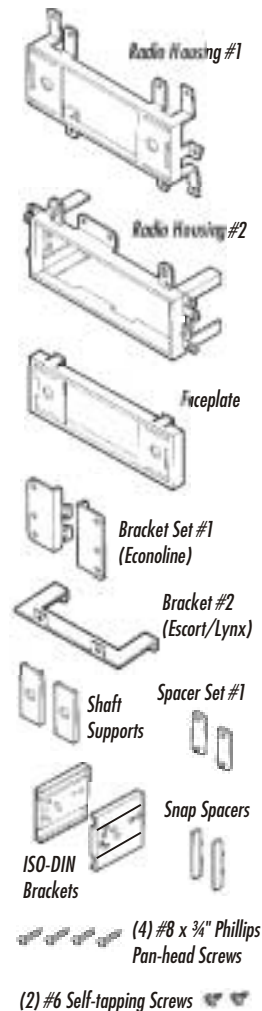

TOOLS REQUIRED



Phillips screwdriver



Cutting tool



86-5618 - Head unit removal keys

99-5700 AT-509FD AW-509FD DW-5510 INSTALLATION INSTRUCTIONS

APPLICATIONS

**FORD/JEEP/LINCOLN/MAZDA/MERCURY 1975-00
(SEE INSIDE FOR SPECIFIC APPLICATIONS)**



TABLE OF CONTENTS

<u>CAR</u>	<u>PAGE</u>	<u>CAR</u>	<u>PAGE</u>	<u>CAR</u>	<u>PAGE</u>
FORD		MERCURY (cont.)		JAGUAR	
Aerostar 1992-97.....	1	Cougar 1989-97.....	12	XJ6 19868-93.....	22
Aerostar 1985-91.....	1	Cougar 1983-88.....	12	LANCIA	
Aspire 1994-97.....	2	Grand Marquis 1991-94.....	5	Beta 1979-81.....	22
Bronco 1992-96.....	8	Grand Marquis 1979-90.....	5	MASERATI	
Bronco (full) 1987-91.....	3	Lynx 1985-87.....	7	Spyder 1985-90.....	22
Bronco 1980-86.....	2	Mystique 1995-009.....	4	MERCEDES	
Bronco II 1989-90.....	3	Marquis 1979-81.....	5	240/280/300/380/420/450	
Bronco II 1985-88.....	4	Sable 1990-95.....	9	500SLC/SEL 1970-96.....	22
Contour 1995-00.....	4	Sable 1986-89.....	10	MITSUBISHI	
Crown Victoria 1992-94.....	5	Topaz 1989-94.....	11	Mighty Max 1987-96.....	22
Crown Victoria 1979-90.....	5	Topaz 1985-88.....	11	Mirage 1993-02.....	22
Econoline 1992-96.....	6	Tracer 1991-96.....	7	PEUGEOT	
Econoline 1975-91.....	6	Tracer (hatch) 19869-90.....	20	405 1989-91.....	22
Escort 1991-96.....	7	Villager 1993-95.....	20	505 1984-913.....	22
Escort 1985-90.....	7	NISSAN		PONTIAC	
Explorer 1991-94.....	3	Quest 1993-95.....	20	LeMans 1988-93.....	22
F-Series Pickup 1992-96.....	8	ADDITIONAL VEHICLES:		PORSCHE	
F-Series Pickup 1987-91.....	3	ACURA		911 1973-99.....	22
F-Series Pickup 1980-86.....	2	Integra 1986-89.....	22	924 1977-82.....	22
Festiva 1988-93.....	8	Legend 1986-89.....	22	924S 1986-88.....	22
LTD 1980-91.....	5	ALFA ROMEO		928 1980-96.....	22
Mustang 1994-00.....	9	Milano 1980-89.....	22	944 1983-93.....	22
Probe 1993-97.....	9	Spider Veloce 1987-93.....	22	968 1992-96.....	22
Ranger (mini) 1989-94.....	3	164 L/S 1991-93.....	22	Boxter 1997-2001.....	24
Ranger (mini) 1983-88.....	4	AUDI		RENAULT	
Taurus 1990-95.....	10	80/90 1988-96.....	22	Alliance 19824-85.....	22
Taurus 1986-89.....	10	100/200 1989-95.....	22	Encore 1984-87.....	22
Tempo 1989-94.....	11	4000 1980-87.....	22	Fuego 1982-85.....	22
Tempo 1985-88.....	11	5000 1978-88.....	22	LeCar 1973-83.....	22
Thunderbird 1989-97.....	12	S4 1992-93.....	22	18i 1979-83.....	22
Thunderbird 1983-88.....	12	BMW		SAAB	
Windstar 1995-98.....	13	3-Series 1977-98.....	22	900 1979-98.....	22
JEEP		5-Series 1975-96.....	22	9000 1986-986.....	22
Cherokee 1984-96.....	13	6-Series 1977-89.....	22	STERLING	
Cherokee 1996.....	14	7-Series 1978-98.....	22	825 1987-88.....	22
Commanche 1985-92.....	13	8-Series 19901-93.....	22	827 19889-92.....	22
Grand Wagoneer 1987-95.....	14	DAIHATSU		SUZUKI	
Wagoneer 1984-96.....	13	Charade 1989-92.....	22	Samurai 1988½-93.....	22
Wrangler 1984-96.....	15	DODGE		Sidekick 1989-91.....	22
LINCOLN		Colt 1993-94.....	22	Swift 1989-91.....	22
Continental 1988-94.....	15	D50 Pickup 1988-93.....	22	X-90 1996-99.....	22
Continental 1985-87.....	16	EAGLE		VOLKSWAGEN	
Mark VII 1990-92.....	15	Summit 1993-94.....	22	Bus 1968-79.....	22
Mark VII 1984-89.....	16	FIAT		Cabriolet 1985-93.....	22
Mark VIII 1993-95.....	17	Beretpme X19 1985-88.....	22	Cabro 1995-01.....	22
Town Car 1990-974.....	15	Brava 1979-83.....	22	Corrado 1990-93.....	22
Town Car 1984-89.....	17	Spider 1970-83.....	22	Dasher 1976-81.....	22
MAZDA		Strada 1977-83.....	22	Fox 1987-93.....	22
B-Series Pickup 1994.....	3	X19 1979-89.....	22	Golf 1985-00.....	22
626 1993-00.....	18	GEO		Passat 1990-979.....	22
MPV 1996-99.....	18	Metro 1989-91.....	22	Pickup 1980.....	22
MX3 1992-96.....	18	Tracker 1989-91.....	22	Rabbit 1975-84.....	22
MX6 1993-97.....	18	HONDA		Scirocco 1981-87.....	22
Navajo 1991-94.....	3	Accord 1982-89.....	22	Super Beetle 1973-79.....	22
Protege 1995-00.....	19	CRX 1984-91.....	22	Quantum 1982-88.....	22
MERCURY		Civic 1982-95.....	22	Vanwagon 1980-92.....	22
Capri XR2 1991-94.....	19	Del Sol 1993-97.....	22		
		Prelude 1983-97.....	22		

ALL VEHICLES

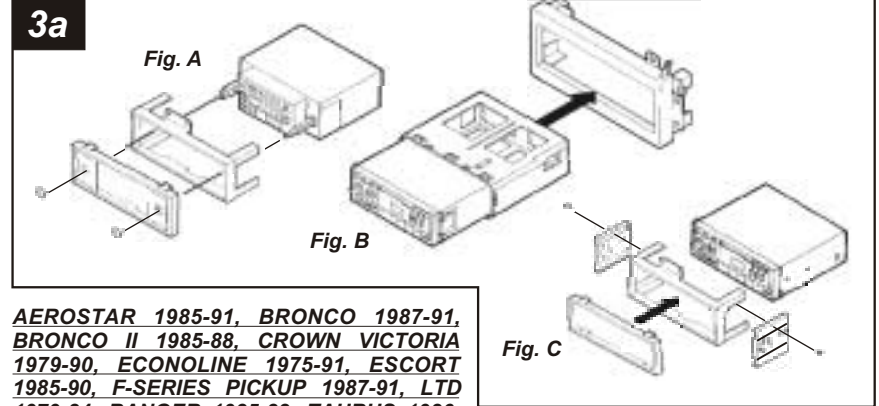

AEROSTAR 1985-91, BRONCO 1987-91, BRONCO II 1985-88, CROWN VICTORIA 1979-90, ECONOLINE 1975-91, ESCORT 1985-90, F-SERIES PICKUP 1987-91, LTD 1979-84, RANGER 1985-88, TAURUS 1986-89, THUNDERBIRD 1985-88, CONTINENTAL 1985-87, MARK VII 1984-89, TOWN CAR 1984-89, COUGAR 1985-88, GRAND MARQUIS 1979-90, LYNX 1985-90, MARQUIS 1979-90, SABLE 1986-89, TRACER (hatchback) 1988-90, all JEEPS: For 2-Shaft units, snap the Faceplate into **Radio Housing #2**. Slide the aftermarket head unit into the kit and secure with shaft nuts. (see Fig. A). For DIN units, slide the DIN cage into **Radio Housing #2** and secure by bending the metal locking tabs down. (The **Snap Spacers** may be added for a semi-recessed installation). Slide the aftermarket head unit into the cage until secure. (see Fig. B). For ISO-DIN units, cut and remove the shaft supports from the **Faceplate**. Snap the Faceplate into **Radio Housing #2** and slide the head unit into the back of the kit. Attach the **ISO-DIN Brackets** to the Housing legs, align the Bracket holes with the unit holes and secure the Brackets with (2) #6 Self-tapping Screws. (see Fig. C)

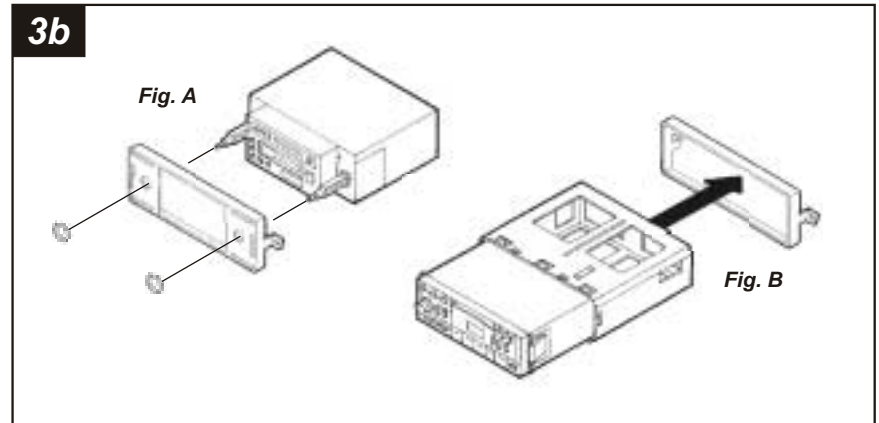

BRONCO 1980-86, F-SERIES PICKUP 1980-86, FESTIVA 1988-93, TEMPO 1985-88, TOPAZ 1985-88: For 2-Shaft units, slide the aftermarket head unit into **Radio Housing #1** and secure with shaft nuts. (see Fig. A). For Din units, cut and remove the shaft supports from **Radio Housing #1**. Slide the DIN cage into the Housing and secure by bending the metal locking tabs down. Slide the aftermarket head unit into the cage until secure. (see Fig. B)

MERCURY Tracer (hatchback) 1989-90

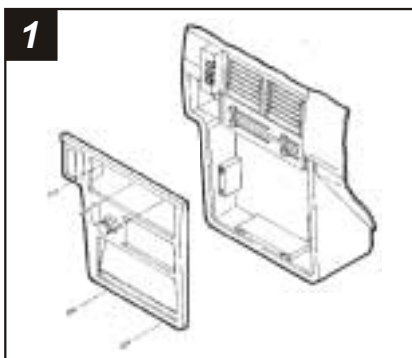

Disconnect the negative battery terminal to prevent an accidental short circuit. Remove (3) Phillips screws from the top of the dash trim bezel. Remove the ashtray and (2) Phillips screws from the bottom of the bezel. Remove (4) Phillips screws securing the factory head unit and disconnect the wiring.

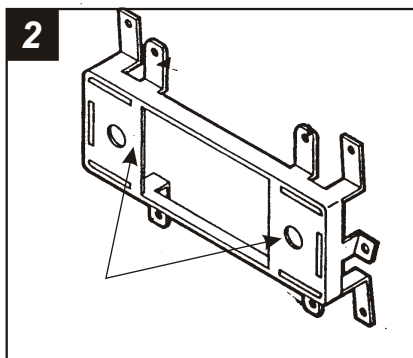

Cut and remove the shaft supports from the **Faceplate**. Skip to step #3c in the *Installation Instructions for ALL VEHICLES* on Page #22.

FORD Aerostar 1992-97

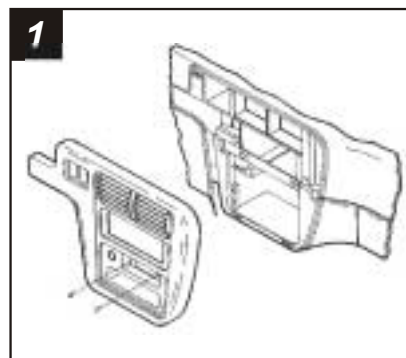

Disconnect the negative battery terminal to prevent an accidental short circuit. Remove (2) screws from the steering column trim panel and (2) screws from the ashtray cavity. Unclip the dash trim bezel. Using Metra's **86-5618**, pull the factory head unit from the dash and disconnect the wiring.

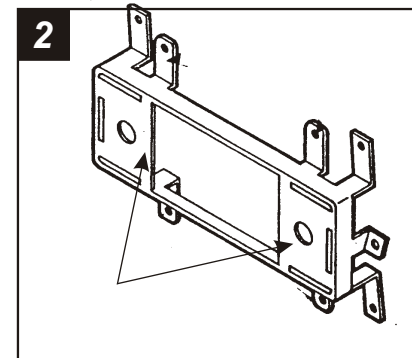

Cut and remove the shaft supports from the **Faceplate**. Skip to step #3c in the *Installation Instructions for ALL VEHICLES* on Page #22.

MERCURY Villager 1993-96 / NISSAN Quest 1993-95

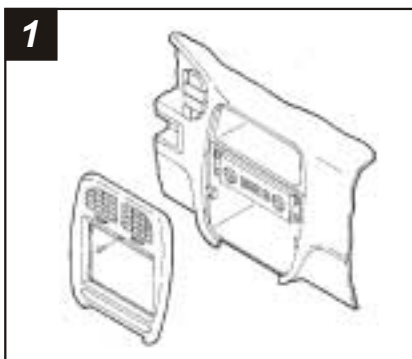

Disconnect the negative battery terminal to prevent an accidental short circuit. Remove (1) screw above the climate controls. Unclip the dash trim bezel. Using Metra's **86-5618**, pull the factory head unit from the dash and disconnect the wiring.

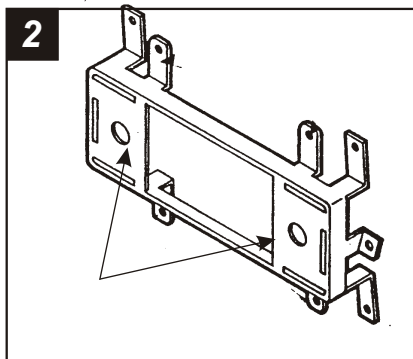

Cut and remove the shaft supports from the **Faceplate**. Skip to step #3c in the *Installation Instructions for ALL VEHICLES* on Page #22.

FORD Aerostar 1985-91

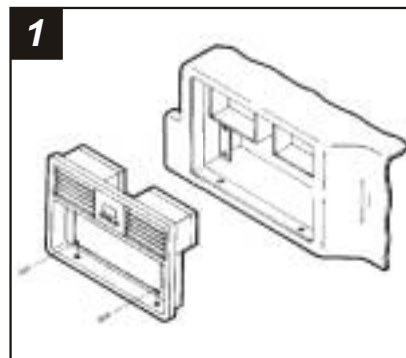

Disconnect the negative battery terminal to prevent an accidental short circuit. Remove (2) Phillips screws from the base of the dash trim bezel. Pry down on the (2) tabs located at the top of the dash trim bezel and remove the bezel. Remove (4) screws securing the factory head unit and disconnect the wiring.

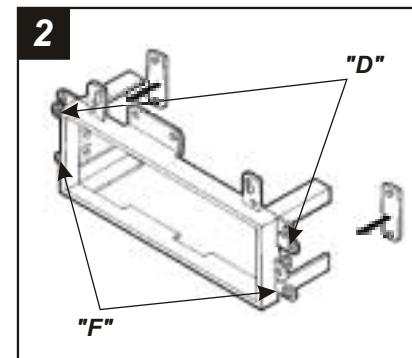

Cut and remove all mounting tabs on **Radio Housing #2** EXCEPT tabs "D" and "F". The mounting tabs can be identified by the stamped letter on the back of each tab. Locate **Spacer Set #1**. (The Spacers must be placed behind the mounting tabs during installation in step #5). Skip to the *Installation Instructions for ALL VEHICLES* on Page #21.

FORD Aspire 1994-97

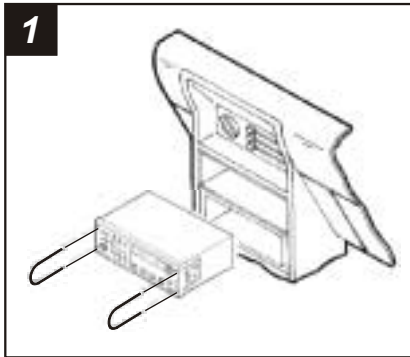

1
Disconnect the negative battery terminal to prevent an accidental short circuit. Using Metra's **86-5618**, pull the factory head unit from the dash and disconnect the wiring.

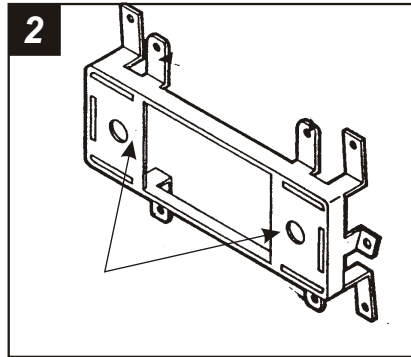

2
Cut and remove the shaft supports from the **Faceplate**. Skip to step #3c in the *Installation Instructions for ALL VEHICLES* on Page #22.

MAZDA Protege 1995-00

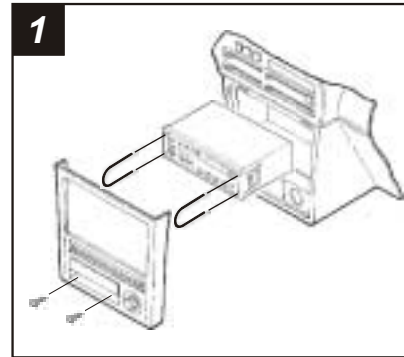

1
Disconnect the negative battery terminal to prevent an accidental short circuit. Remove the ashtray and (2) screws from the ashtray cavity. Using Metra's **86-5618**, pull the factory head unit from the dash and disconnect the wiring.

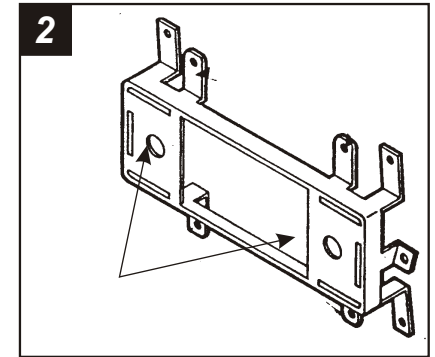

2
Cut and remove the shaft supports from the **Faceplate**. Skip to step #3c in the *Installation Instructions for ALL VEHICLES* on Page #22.

FORD Bronco / Pickup 1980-86

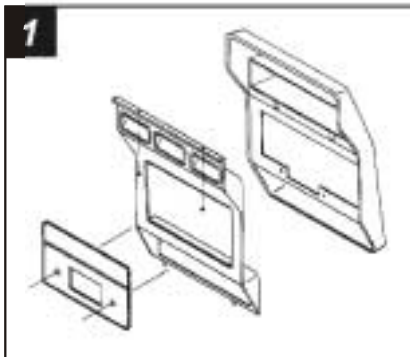

1
Disconnect the negative battery terminal to prevent an accidental short circuit. Remove (2) screws from the top edge of the dash trim bezel. Pull out on the top of the bezel, unhook the base and remove the bezel. If a factory head unit is NOT present, scribe the (4) mounting holes and radio opening onto the bezel. Drill the holes, cut the opening and place (4) U-clips over the mounting positions.

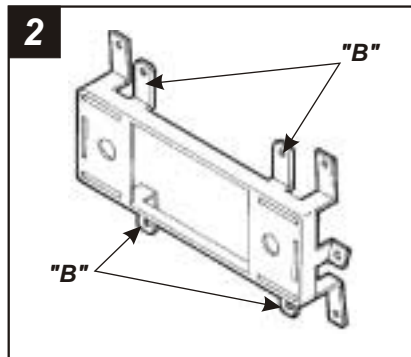

2
Cut and remove all mounting tabs on **Radio Housing #1** EXCEPT tabs "B". The mounting tabs can be identified by the stamped letter on the back of each tab. Skip to the *Installation Instructions for ALL VEHICLES* on Page #21.

MERCURY Capri XR2 1991-94

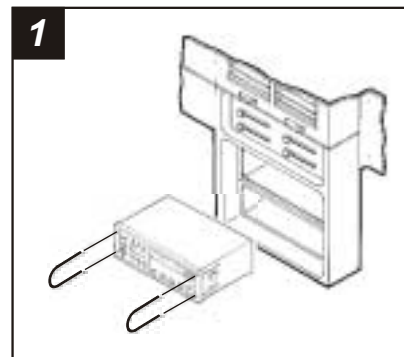

1
Disconnect the negative battery terminal to prevent an accidental short circuit. Using Metra's **86-5618**, pull the factory head unit from the dash and disconnect the wiring.

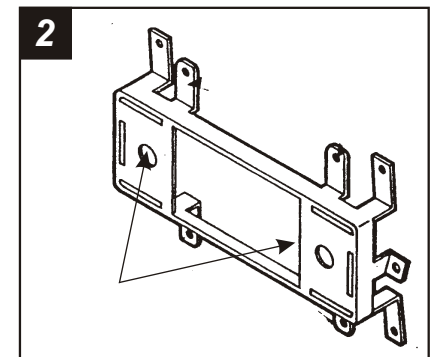

2
Cut and remove the shaft supports from the **Faceplate**. Skip to step #3c in the *Installation Instructions for ALL VEHICLES* on Page #22.

MAZDA MPV 1996-99

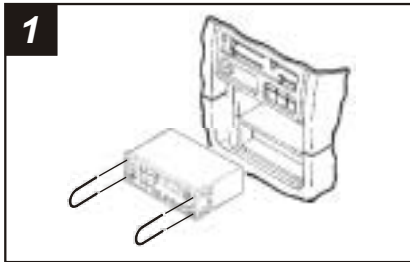

1
Disconnect the negative battery terminal to prevent an accidental short circuit. Unsnap the side trim pieces from the factory head unit. Using Metra's **86-5618**, pull the unit from the dash and disconnect the wiring.

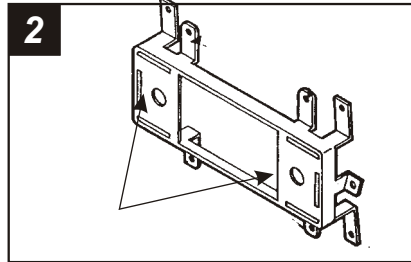

2
Cut and remove the shaft supports from the **Faceplate**. Skip to step #3c in the *Installation Instructions for ALL VEHICLES* on Page #22.

MAZDA MX3 1992-96

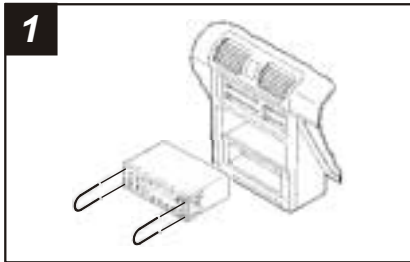

1
Disconnect the negative battery terminal to prevent an accidental short circuit. Using Metra's **86-5618**, pull the factory head unit from the dash and disconnect the wiring.

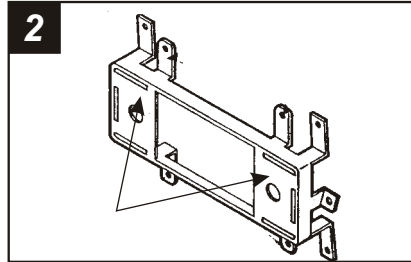

2
Cut and remove the shaft supports from the **Faceplate**. Skip to step #3c in the *Installation Instructions for ALL VEHICLES* on Page #22.

MAZDA MX6 1993-97 / 626 1993-00

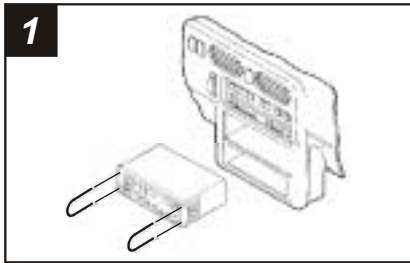

1
Disconnect the negative battery terminal to prevent an accidental short circuit. Using Metra's **86-5618**, pull the factory head unit from the dash and disconnect the wiring.

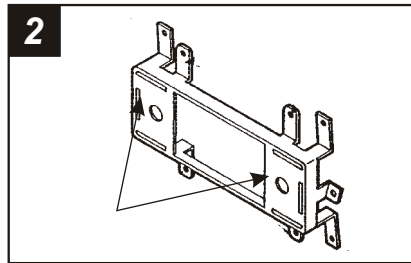

2
Cut and remove the shaft supports from the **Faceplate**. Skip to step #3c in the *Installation Instructions for ALL VEHICLES* on Page #22.

FORD Bronco (full size) / F-Series Pickup 1987-91

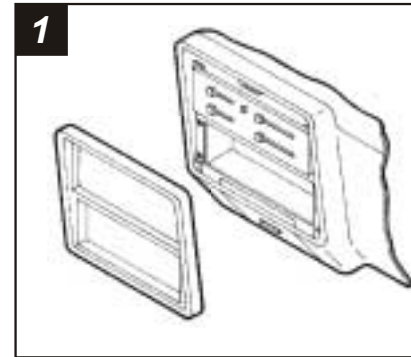

1
Disconnect the negative battery terminal to prevent an accidental short circuit. Carefully pull and remove the dash trim bezel. Remove (4) screws securing the factory head unit and disconnect the wiring.

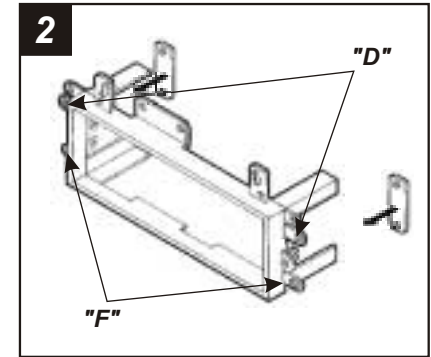

2
Cut and remove all mounting tabs on **Radio Housing #2** EXCEPT tabs "D" and "F". The mounting tabs can be identified by the stamped letter on the back of each tab. Locate **Spacer Set #1**. (The Spacers must be placed behind the mounting tabs during installation in step #5). Skip to the *Installation Instructions for ALL VEHICLES* on Page #21.

FORD Bronco II 1989-90 / Explorer 1991-94 / Ranger 1989-94 MAZDA Navajo 1991-94 / B-Series Pickup 1994

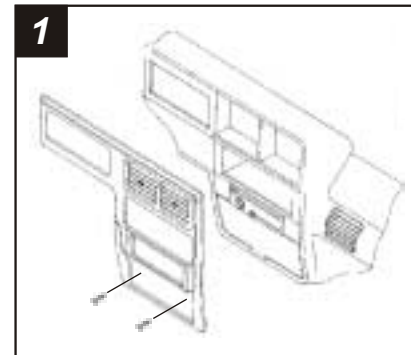

1
Disconnect the negative battery terminal to prevent an accidental short circuit. Remove the ashtray and (2) screws exposed in the ashtray cavity. Using Metra's **86-5618**, pull the factory head unit from the dash and disconnect the wiring.

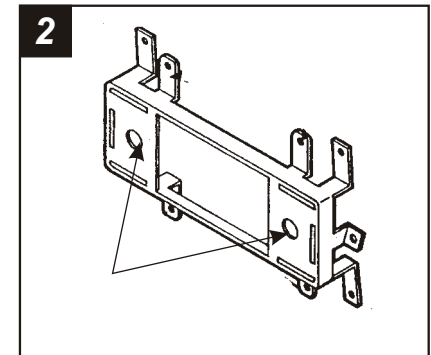

2
Cut and remove the shaft supports from the **Faceplate**. Skip to step #3c in the *Installation Instructions for ALL VEHICLES* on Page #22.

FORD Bronco II / Ranger 1985-88

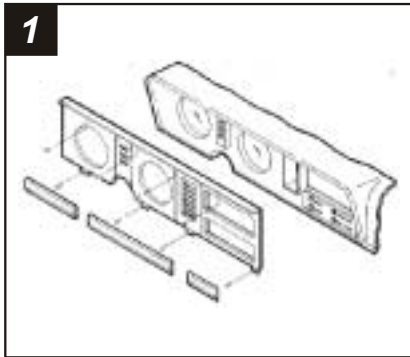

Disconnect the negative battery terminal to prevent an accidental short circuit. Remove (4) Phillips screws from the top edge of the dash trim bezel. Remove the light switch knob, cigarette lighter and ashtray. Unsnap the molding located below the dash trim bezel and remove (4) screws exposed. Remove (4) screws securing the factory head unit and disconnect the wiring.

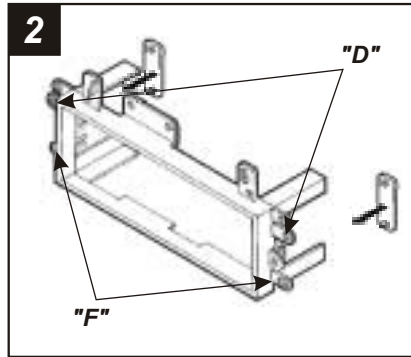

Cut and remove all mounting tabs on **Radio Housing #2** EXCEPT tabs "D" and "F". The mounting tabs can be identified by the stamped letter on the back of each tab. Locate **Spacer Set #1**. (The Spacers must be placed behind the mounting tabs during installation in step #5). Skip to the *Installation Instructions for ALL VEHICLES on Page #21*.

LINCOLN Mark VIII 1993-95

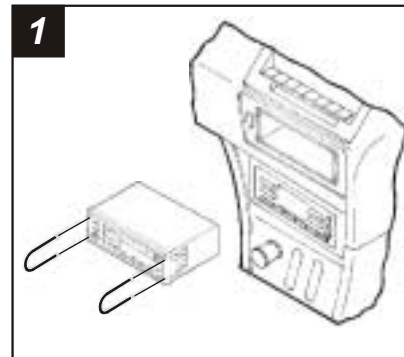

Disconnect the negative battery terminal to prevent an accidental short circuit. Using Metra's **86-5618**, pull the factory head unit from the dash and disconnect the wiring.

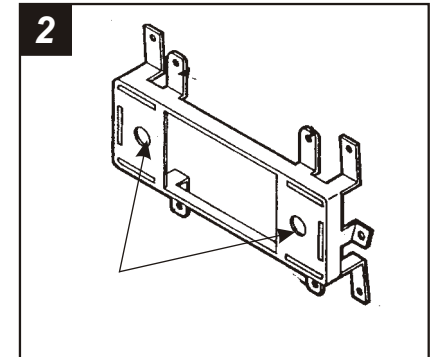

Cut and remove the shaft supports from the **Faceplate**. Skip to step #3c in the *Installation Instructions for ALL VEHICLES on Page #22*.

FORD Contour 1995-00 / MERCURY Mystique 1995-99

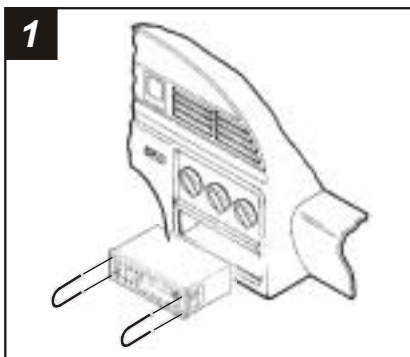

Disconnect the negative battery terminal to prevent an accidental short circuit. Using Metra's **86-5618**, pull the factory head unit from the dash and disconnect the wiring.

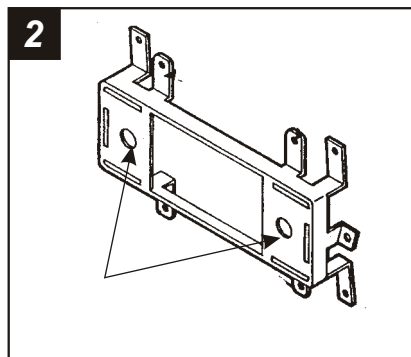

Cut and remove the shaft supports from the **Faceplate**. Skip to step #3c in the *Installation Instructions for ALL VEHICLES on Page #22*.

LINCOLN Town Car 1984-89

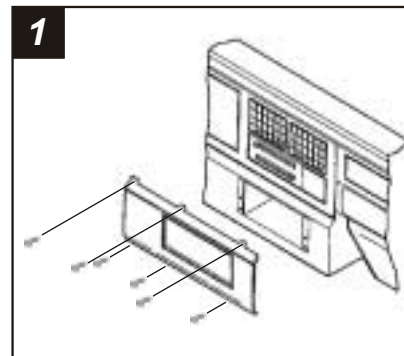

Disconnect the negative battery terminal to prevent an accidental short circuit. Remove (3) #8 Phillips screws from the bottom of the radio trim bezel. Unsnap the plastic strip located above the bezel and remove (3) Phillips screws exposed. Gently pull the instrument cluster trim bezel away from the dash and remove the radio trim bezel. Remove (3) hex-head screws securing the factory head unit and disconnect the wiring.

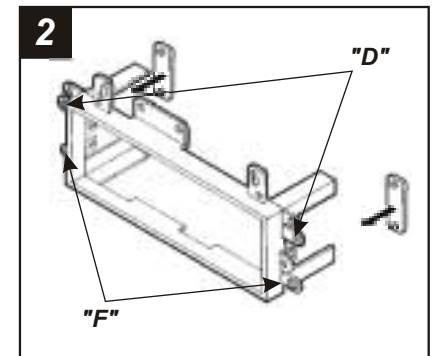

Cut and remove all mounting tabs on **Radio Housing #2** EXCEPT tabs "D" and "F". The mounting tabs can be identified by the stamped letter on the back of each tab. Locate **Spacer Set #1**. (The Spacers must be placed behind the mounting tabs during installation in step #5). Skip to the *Installation Instructions for ALL VEHICLES on Page #21*.

LINCOLN Continental 1985-87

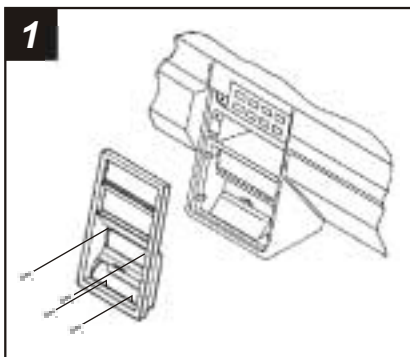

Disconnect the negative battery terminal to prevent an accidental short circuit. Remove (2) #8 Phillips screws below the radio opening. Open the ashtray and remove (2) #8 Phillips screws exposed (it is NOT necessary to remove the center screw). Unclip and remove the dash trim bezel. Remove (4) hex-head screws securing the factory head unit and disconnect the wiring.

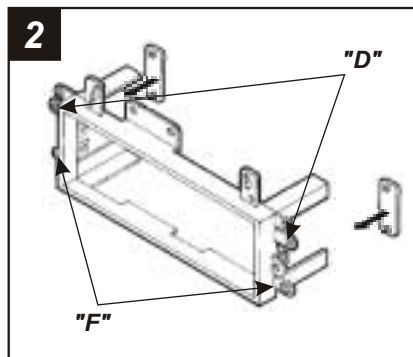

Cut and remove all mounting tabs on **Radio Housing #2** EXCEPT tabs "D" and "F". The mounting tabs can be identified by the stamped letter on the back of each tab. Locate **Spacer Set #1**. (The Spacers must be placed behind the mounting tabs during installation in step #5). Skip to the *Installation Instructions for ALL VEHICLES on Page #21*.

LINCOLN Mark VII 1984-89

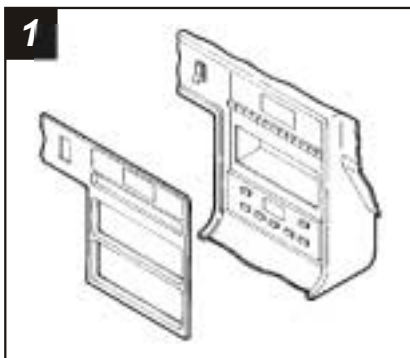

Disconnect the negative battery terminal to prevent an accidental short circuit. Gently pry out on the dash trim bezel and remove. Remove (4) 5mm hex-head sheet metal screws securing the factory head unit and disconnect the wiring.

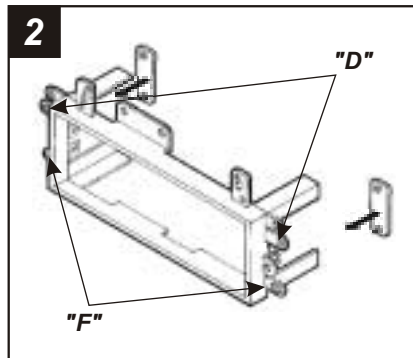

Cut and remove all mounting tabs on **Radio Housing #2** EXCEPT tabs "D" and "F". The mounting tabs can be identified by the stamped letter on the back of each tab. Locate **Spacer Set #1**. (The Spacers must be placed behind the mounting tabs during installation in step #5). Skip to the *Installation Instructions for ALL VEHICLES on Page #21*.

FORD Crown Victoria 1991-94 MERCURY Grand Marquis 1991-94

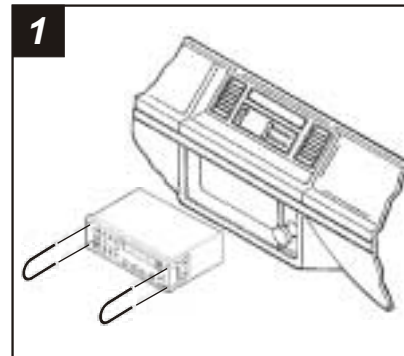

Disconnect the negative battery terminal to prevent an accidental short circuit. Using Metra's **86-5618**, pull the factory head unit from the dash and disconnect the wiring.

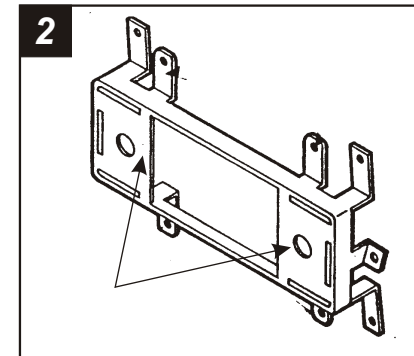

Cut and remove the shaft supports from the **Faceplate**. Skip to step #3c in the *Installation Instructions for ALL VEHICLES on Page #22*.

FORD Crown Victoria / LTD 1979-90 MERCURY Grand Marquis / Marquis 1979-90

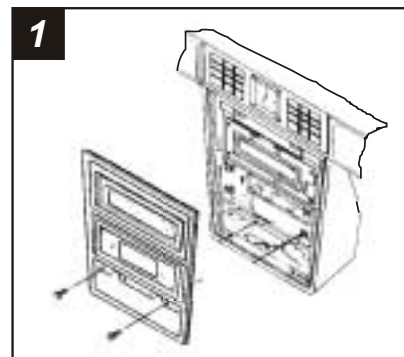

Disconnect the negative battery terminal to prevent an accidental short circuit. Open the ashtray and remove (2) Phillips screws securing the dash trim bezel. Remove (4) screws securing the factory head unit and disconnect the wiring.

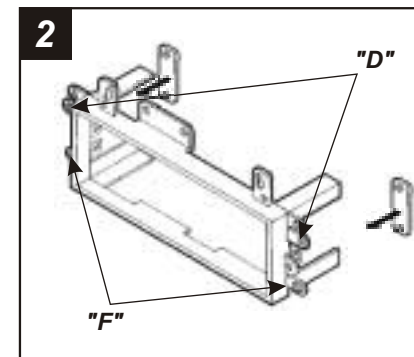

Cut and remove all mounting tabs on **Radio Housing #2** EXCEPT tabs "D" and "F". The mounting tabs can be identified by the stamped letter on the back of each tab. Locate **Spacer Set #1**. (The Spacers must be placed behind the mounting tabs during installation in step #5). Skip to the *Installation Instructions for ALL VEHICLES on Page #21*.

FORD Econoline 1992-96

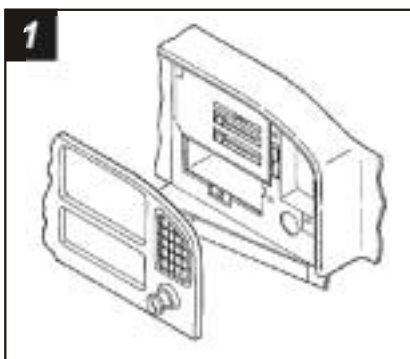

Disconnect the negative battery terminal to prevent an accidental short circuit. Remove the light switch knob and unscrew the surrounding trim. Remove the cupholder and the screws exposed in the cupholder cavity. Unsnap the (2) trim bezel inserts and remove the screws exposed. Remove the lower steering column trim panel and unclip the dash trim bezel. Using Metra's **86-5618**, pull the factory head unit from the dash and disconnect the wiring.

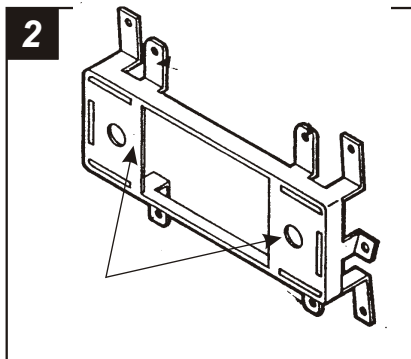

Cut and remove the shaft supports from the **Faceplate**. Skip to step #3c in the *Installation Instructions for ALL VEHICLES on Page #22*.

JEEP Wrangler 1986-96

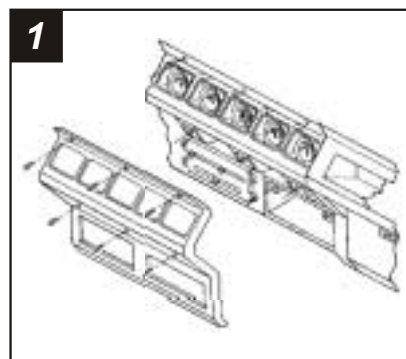

Disconnect the negative battery terminal to prevent an accidental short circuit. Remove (6) Phillips screws from the face of the dash trim bezel. Remove the bezel. Remove (2) screws securing the factory head unit and disconnect the wiring.

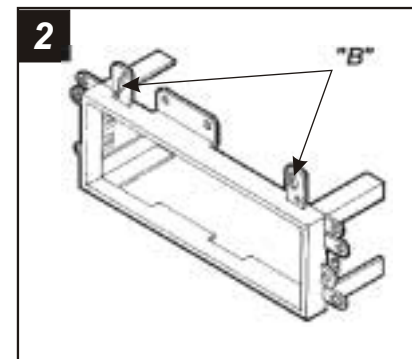

Cut and remove all mounting tabs on **Radio Housing #2** EXCEPT tabs "B". The mounting tabs can be identified by the stamped letter on the back of each tab. Skip to the *Installation Instructions for ALL VEHICLES on Page #21*.

FORD Econoline 1975-91

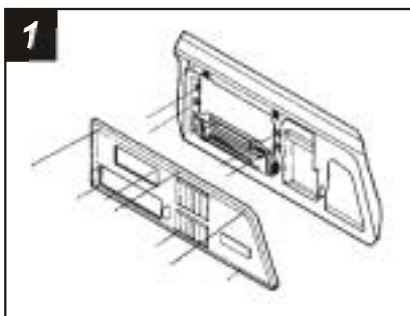

Disconnect the negative battery terminal to prevent an accidental short circuit. Remove (3) screws from the lower edge of the dash trim bezel. Remove (2) screws above the radio opening. Unsnap the right corner of the dash trim bezel, disconnect the cigarette lighter wiring and remove the bezel. Remove the screws securing the factory head unit and disconnect the wiring.

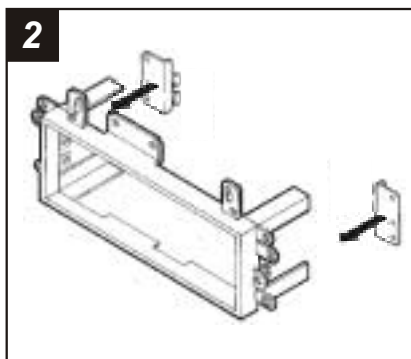

Cut and remove all mounting tabs on **Radio Housing #2**. The mounting tabs can be identified by the stamped letter on the back of each tab. Slide **Bracket Set #1** into the slots on the sides of the Housing. Skip to the *Installation Instructions for ALL VEHICLES on Page #21*.

LINCOLN Continental 1988-94 / Mark VII 1990-92 Town Car 1990-94

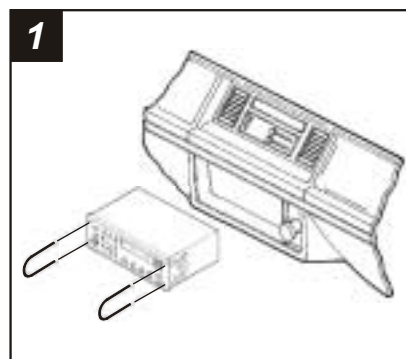

Disconnect the negative battery terminal to prevent an accidental short circuit. Using Metra's **86-5618**, pull the factory head unit from the dash and disconnect the wiring.

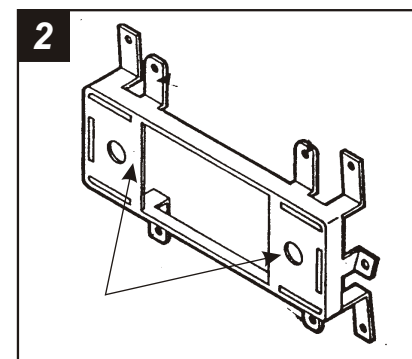

Cut and remove the shaft supports from the **Faceplate**. Skip to step #3c in the *Installation Instructions for ALL VEHICLES on Page #22*.

JEEP Cherokee 1996

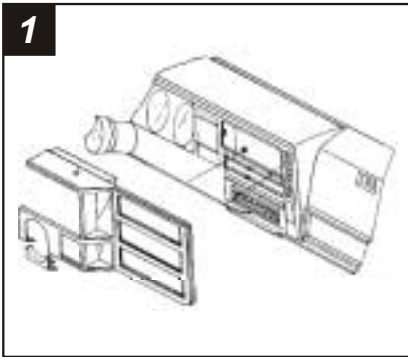

1
Disconnect the negative battery terminal to prevent an accidental short circuit. Remove (3) torx-head screws from the steering column trim panels. Unscrew the tilt steering lever and unsnap the trim panels. Remove (4) screws from the dash trim bezel and remove the bezel. Remove (2) screws securing the factory head unit and disconnect the wiring.

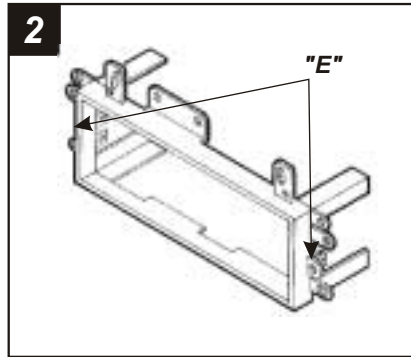

2
Cut and remove all mounting tabs on **Radio Housing #2** EXCEPT tabs "E". The mounting tabs can be identified by the stamped letter on the back of each tab. Skip to the *Installation Instructions for ALL VEHICLES* on Page #21.

FORD Escort / MERCURY Tracer 1991-96

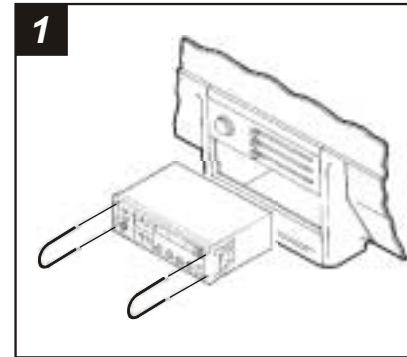

1
Disconnect the negative battery terminal to prevent an accidental short circuit. Using Metra's **86-5618**, pull the factory head unit from the dash and disconnect the wiring.

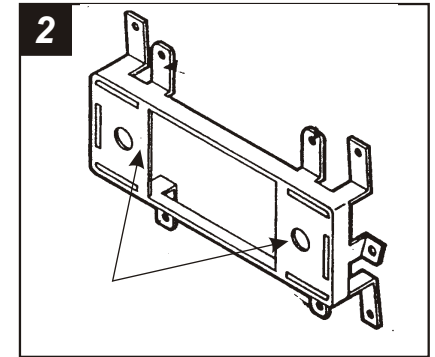

2
Cut and remove the shaft supports from the **Faceplate**. Skip to step #3c in the *Installation Instructions for ALL VEHICLES* on Page #22.

JEEP Grand Wagoneer 1987-95

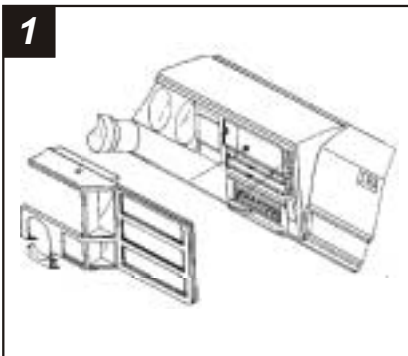

1
Disconnect the negative battery terminal to prevent an accidental short circuit. Gently unclip the dash trim bezel. Remove (2) screws securing the factory head unit and disconnect the wiring.

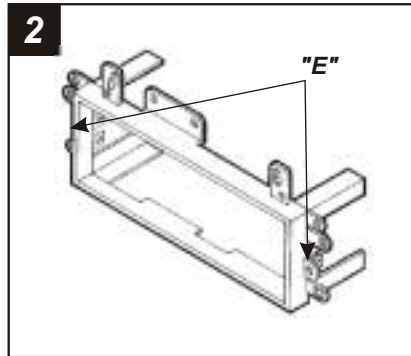

2
Cut and remove all mounting tabs on **Radio Housing #2** EXCEPT tabs "E". The mounting tabs can be identified by the stamped letter on the back of each tab. Skip to the *Installation Instructions for ALL VEHICLES* on Page #21.

FORD Escort / MERCURY Lynx 1985-90

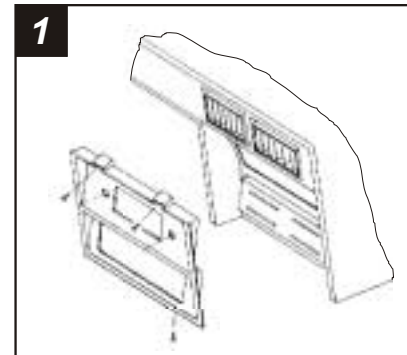

1
Disconnect the negative battery terminal to prevent an accidental short circuit. Remove (4) screws from the top edge of the dash trim bezel. Remove (2) screws from the bottom edge of the dash trim bezel. Remove the climate control knobs and remove the bezel. Remove (4) hex-head screws securing the factory head unit and disconnect the wiring.

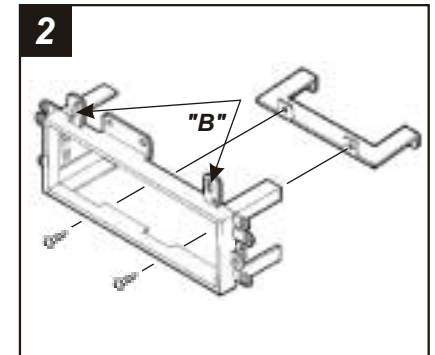

2
Cut and remove all mounting tabs on **Radio Housing #2** EXCEPT tabs "B". The mounting tabs can be identified by the stamped letter on the back of each tab. Mount **Bracket #2** to the bottom of the Housing with (2) **#8 x 3/4" Phillips Screws** supplied. Skip to the *Installation Instructions for ALL VEHICLES* on Page #21.

FORD F-Series Pickup / Bronco 1992-96

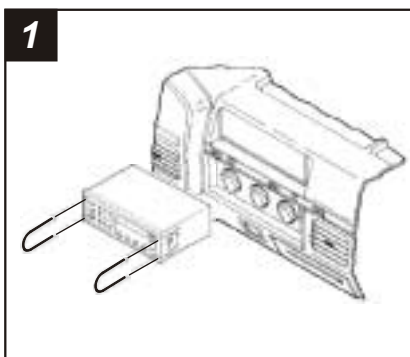

1
Disconnect the negative battery terminal to prevent an accidental short circuit. Using Metra's **86-5618**, pull the factory head unit from the dash and disconnect the wiring.

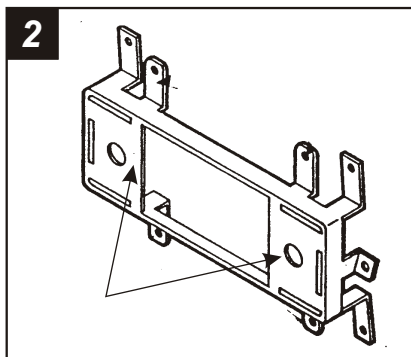

2
Cut and remove the shaft supports from the **Faceplate**. Skip to step #3c in the *Installation Instructions for ALL VEHICLES* on Page #22.

FORD Windstar 1995-98

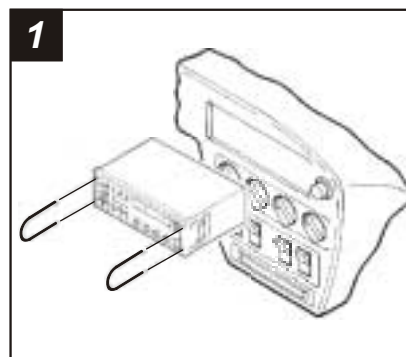

1
Disconnect the negative battery terminal to prevent an accidental short circuit. Using Metra's **86-5618**, pull the factory head unit from the dash and disconnect the wiring.

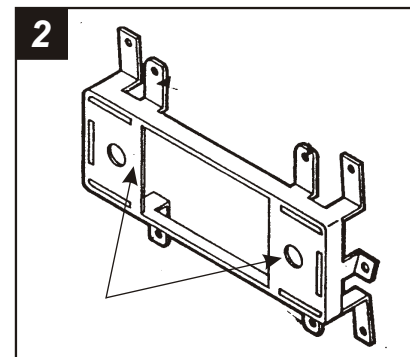

2
Cut and remove the shaft supports from the **Faceplate**. Skip to step #3c in the *Installation Instructions for ALL VEHICLES* on Page #22.

FORD Festiva 1988-93

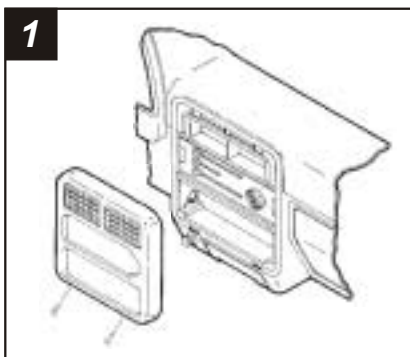

1
Disconnect the negative battery terminal to prevent an accidental short circuit. Remove (4) Phillips screws from the bottom of the dash trim bezel. Remove the bezel. Remove (2) screws securing the factory head unit and disconnect the wiring.

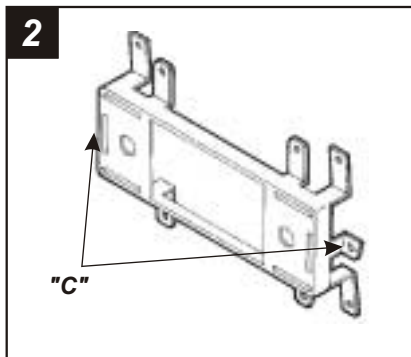

2
Cut and remove all mounting tabs on **Radio Housing #1** EXCEPT tabs "C". The mounting tabs can be identified by the stamped letter on the back of each tab. Skip to the *Installation Instructions for ALL VEHICLES* on Page #21.

JEEP Cherokee 1984-95 / Comanche 1986-92 Wagoneer 1984-96

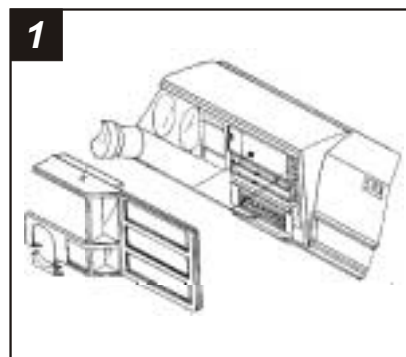

1
Disconnect the negative battery terminal to prevent an accidental short circuit. Unsnap the steering column trim panel and remove. Remove (4) screws from the dash trim bezel and remove the bezel. Remove (2) screws securing the factory head unit and disconnect the wiring.

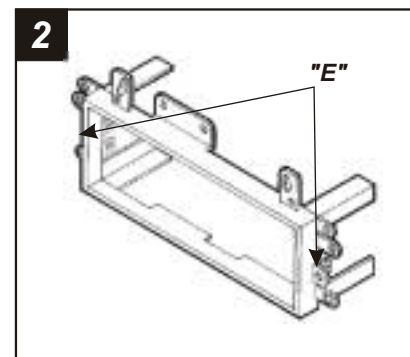

2
Cut and remove all mounting tabs on **Radio Housing #2** EXCEPT tabs "E". The mounting tabs can be identified by the stamped letter on the back of each tab. Skip to the *Installation Instructions for ALL VEHICLES* on Page #21.

FORD Thunderbird / MERCURY Cougar 1989-97

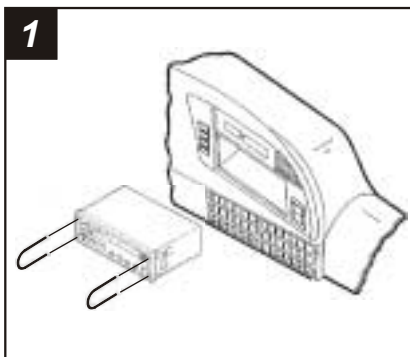

1
Disconnect the negative battery terminal to prevent an accidental short circuit. Using Metra's **86-5618**, pull the factory head unit from the dash and disconnect the wiring.

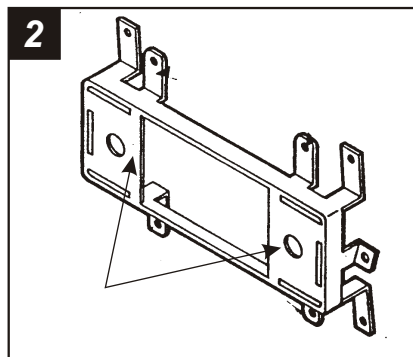

2
Cut and remove the shaft supports from the **Faceplate**. Skip to step #3c in the *Installation Instructions for ALL VEHICLES* on Page #22.

FORD Thunderbird / MERCURY Cougar 1985-88

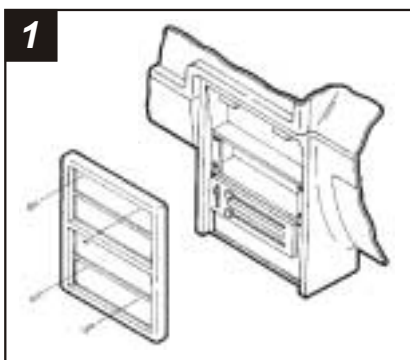

1
Disconnect the negative battery terminal to prevent an accidental short circuit. Remove (2) screws from the top of the dash trim bezel. Open the ashtray and remove (2) screws from the ashtray cavity. Remove (4) screws securing the factory head unit and disconnect the wiring.

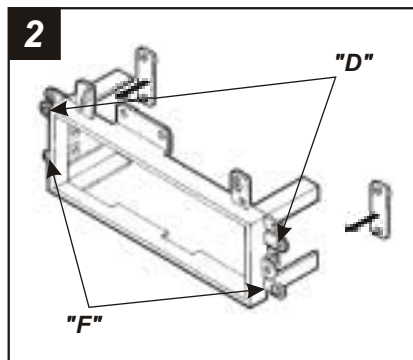

2
Cut and remove all mounting tabs on **Radio Housing #2** EXCEPT tabs "**D**" and "**F**". The mounting tabs can be identified by the stamped letter on the back of each tab. Locate **Spacer Set #1**. (The Spacers must be placed behind the mounting tabs during installation in step #5). Skip to the *Installation Instructions for ALL VEHICLES* on Page #21.

FORD Mustang 1994-00

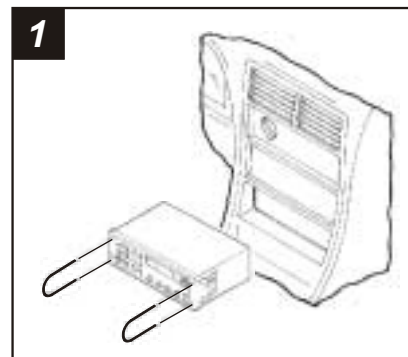

1
Disconnect the negative battery terminal to prevent an accidental short circuit. Using Metra's **86-5618**, pull the factory head unit from the dash and disconnect the wiring.

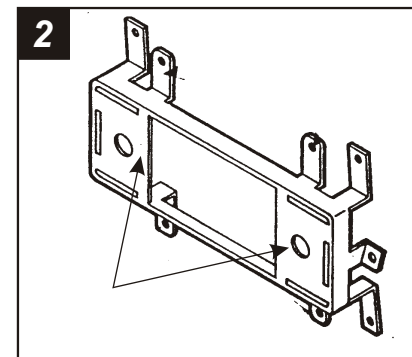

2
Cut and remove the shaft supports from the **Faceplate**. Skip to step #3c in the *Installation Instructions for ALL VEHICLES* on Page #22.

FORD Probe 1993-97

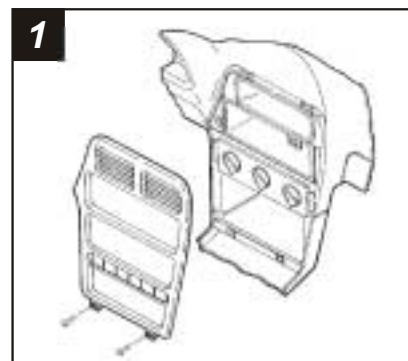

1
Disconnect the negative battery terminal to prevent an accidental short circuit. Remove (2) screws from the base of the dash trim bezel. Unclip and remove the bezel. Using Metra's **86-5618**, pull the factory head unit from the dash and disconnect the wiring.

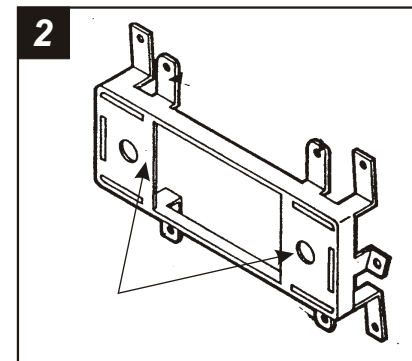

2
Cut and remove the shaft supports from the **Faceplate**. Skip to step #3c in the *Installation Instructions for ALL VEHICLES* on Page #22.

FORD Taurus / MERCURY Sable 1990-95

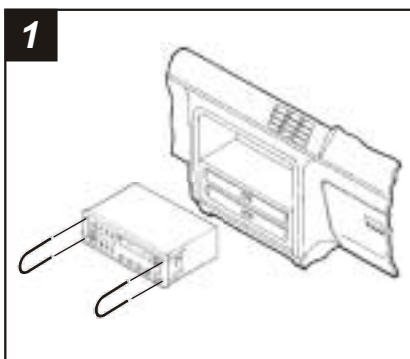

1
Disconnect the negative battery terminal to prevent an accidental short circuit. Using Metra's **86-5618**, pull the factory head unit from the dash and disconnect the wiring.

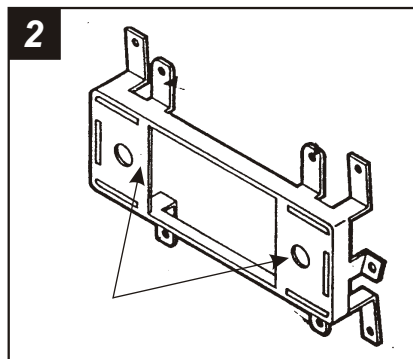

2
Cut and remove the shaft supports from the **Faceplate**. Skip to step #3c in the *Installation Instructions for ALL VEHICLES* on Page #22.

FORD Tempo / MERCURY Topaz 1989-94

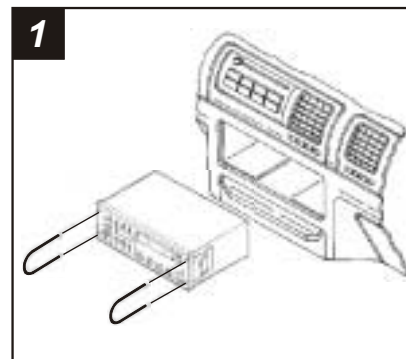

1
Disconnect the negative battery terminal to prevent an accidental short circuit. Using Metra's **86-5618**, pull the factory head unit from the dash and disconnect the wiring.

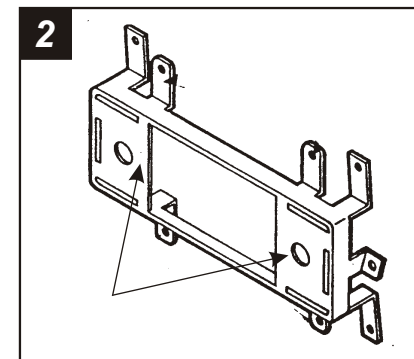

2
Cut and remove the shaft supports from the **Faceplate**. Skip to step #3c in the *Installation Instructions for ALL VEHICLES* on Page #22.

FORD Taurus / MERCURY Sable 1986-89

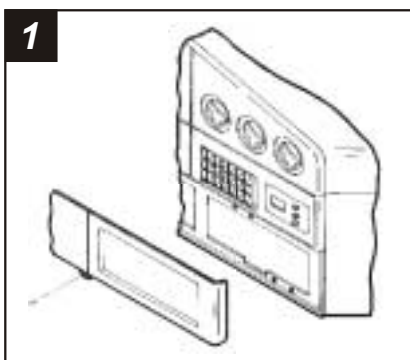

1
Disconnect the negative battery terminal to prevent an accidental short circuit. Remove (1) 7mm hex-head screw from the bottom of the radio trim bezel. Gently unclip the bezel and disconnect the antenna switch power lead. Remove (4) screws securing the factory head unit and disconnect the wiring.

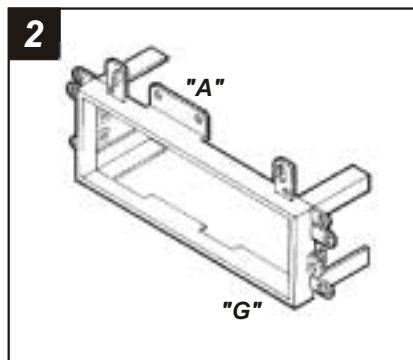

2
Cut and remove all mounting tabs on **Radio Housing #2** EXCEPT tabs "A" and "G". The mounting tabs can be identified by the stamped letter on the back of each tab. Skip to the *Installation Instructions for ALL VEHICLES* on Page #21.

FORD Tempo / MERCURY Topaz 1985-88

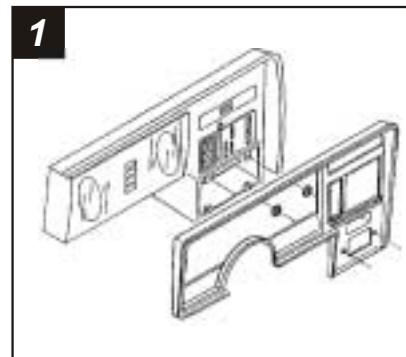

1
Disconnect the negative battery terminal to prevent an accidental short circuit. Remove the ashtray by disengaging the release tab at the rear of the ashtray bracket. Remove (2) screws from the lower edge of the dash trim bezel. Unclip the top edge of the bezel and remove. Remove (4) screws securing the factory head unit and disconnect the wiring.

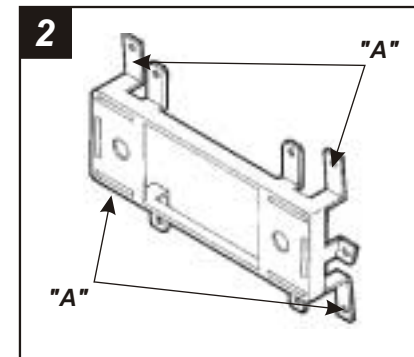

2
Cut and remove all mounting tabs on **Radio Housing #1** EXCEPT tabs "A". The mounting tabs can be identified by the stamped letter on the back of each tab. Skip to the *Installation Instructions for ALL VEHICLES* on Page #21.