

**KIT FEATURES**

- ▶ *Shaft and  
DIN unit  
provisions*

**KIT COMPONENTS**



# 99-6229

## INSTALLATION INSTRUCTIONS

### **APPLICATIONS**

**CHRYSLER / DODGE / EAGLE / JEEP  
PLYMOUTH VEHICLES 1974-00  
(SEE INSIDE FOR SPECIFIC APPLICATIONS)**



**TOOLS REQUIRED**



*Phillips screwdriver*



*Cutting tool*



*Socket wrench*

## APPLICATIONS

### CHRYSLER

Concorde 1993-97  
 Cordoba 1975-78  
 Cordoba 1979-83  
 E-Class 1983-93  
 Fifth Avenue 1990-93  
 Horizon 1978-83  
 Imperial 1982-83  
 Imperial 1990-93  
 Laser 1984-86  
 LeBaron 1976-81  
 LeBaron 1982-85  
 LeBaron 1986-94  
 LeBaron GTS 1985-94  
 LHS 1995-98  
 Newport 1977-80  
 Newport 1980-81  
 New Yorker 1975-81  
 New Yorker 1983-87  
 New Yorker 1988-96  
 Town & Country 1990-95  
 Town & Country 1996-00

### DODGE

Aries 1981-89  
 Aspen 1976-80  
 Caravan 1984-90  
 Caravan 1991-95  
 Caravan 1996-00  
 Charger 1974-78  
 Charger 1983-87  
 Dakota 1987-96  
 Dakota 1997-00  
 Daytona 1984-89  
 Daytona 1990-93  
 Diplomat 1976-89  
 Durango 1998-00  
 Dynasty 1988-93  
 Intrepid 1993-97  
 Lancer 1986-89  
 Magnum XE 1978-79  
 Mirada 1979-83  
 Neon 1995-99

### DODGE (cont.)

Omni 1978-90  
 Pickup 1974-80  
 Pickup 1981-83  
 Ram 1994-02  
 Ramcharger 1974-80  
 Ramcharger 1981-93  
 Rampage 1978-82  
 Shadow 1987-95  
 Spirit 1989-95  
 St. Regis 1979-81  
 Van 1978-02  
 024 1978-82  
 400 1982-83  
 600 1983-87

### EAGLE

Vision 1993-97

### JEEP

Cherokee 1997-01  
 Grand Cherokee 1996-98  
 Wrangler 1997-02

### PLYMOUTH

Acclaim 1989-95  
 Caravelle 1985-87  
 Fury 1975-78  
 Gran Fury 1975-85  
 Horizon 1978-82  
 Neon 1994-99  
 Reliant 1981-89  
 Scamp 1983-84  
 Sundance 1987-94  
 TC3 1978-82  
 Trailduster 1974-80  
 Trailduster 1981  
 Turismo 1983-87  
 Van 1978-97  
 Volare 1976-80  
 Voyager 1984-90  
 Voyager 1991-95  
 Voyager 1996-99

## ALL VEHICLES

Please call Metra's Technical Support line for individual dash disassemblies.

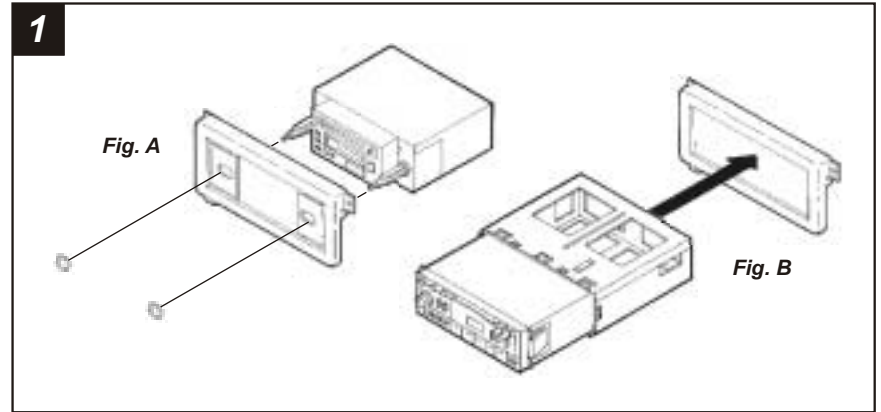

**2-SHAFT HEAD UNITS:** Slide the aftermarket head unit into the kit and secure with shaft nuts. (see Fig. A)

**DIN HEAD UNITS:** Cut and remove the shaft supports from the **Radio Housing**. Slide the DIN cage into the kit and secure by bending the metal locking tabs down. Slide the aftermarket head unit into the cage until secure. (see Fig. B)

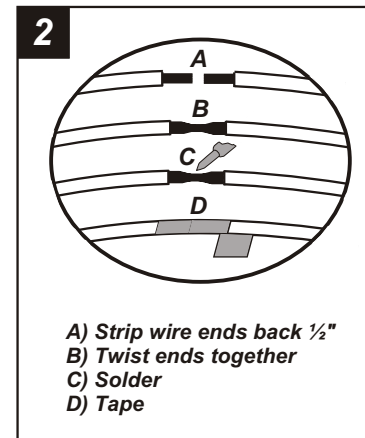

A) Strip wire ends back 1/2"  
 B) Twist ends together  
 C) Solder  
 D) Tape

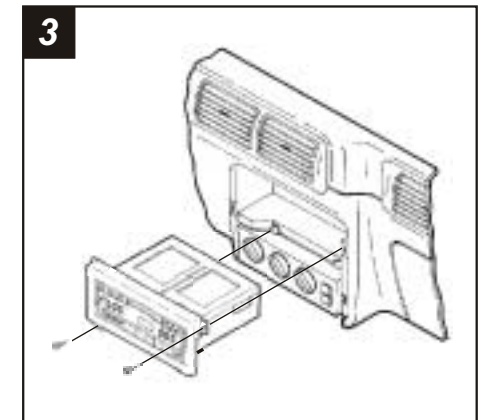

Re-connect the battery terminal and test the unit for proper operation. Mount the head unit/kit assembly to the sub-dash with (2) hex-head screws previously removed in the dash disassembly.