

ALL VEHICLES

2b

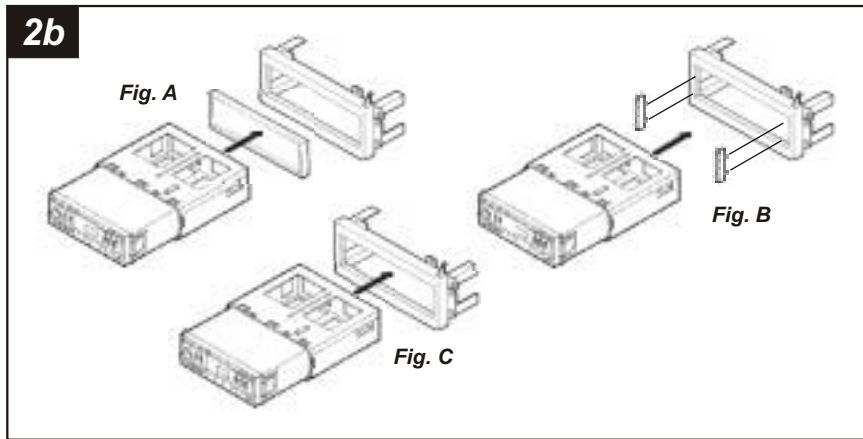

DIN HEAD UNITS: If a *surface-mount installation* is desired, insert the **Spacer** into the **Radio Housing**. Slide the DIN cage into the kit and secure by bending the metal locking tabs down. Slide the aftermarket head unit into the cage until secure. (see Fig. A). If an *intermediate-mount installation* is desired, attach the **Snap Spacers** to the outer walls of the radio opening. Slide the DIN cage into the **Radio Housing** and secure by bending the metal locking tabs down. Slide the aftermarket head unit into the cage until secure. (see Fig. B). If a *flush-mount installation* is desired, slide the DIN cage into the **Radio Housing** and secure by bending the metal locking tabs down. Slide the aftermarket head unit into the cage until secure. (see Fig. C).

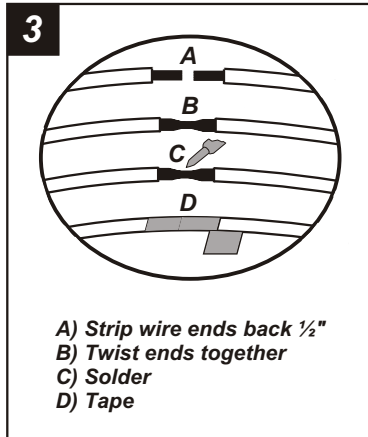

Locate the factory wiring harness in the dash. Metra recommends using the proper mating adaptor and making connections as shown. (Isolate and individually tape off the ends of any unused wires to prevent electrical short circuit).

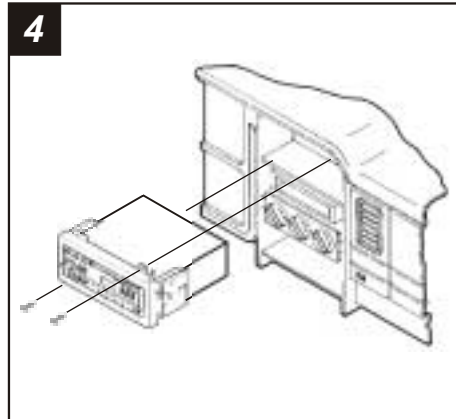

Re-connect the battery terminal and test the unit for proper operation. Mount the head unit/kit assembly to the sub-dash with those screws previously removed in the dash disassembly.

KIT FEATURES

- ▶ Shaft, DIN and ISO-DIN unit provisions

KIT COMPONENTS

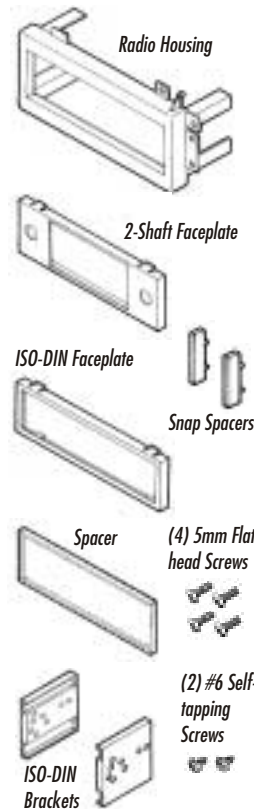

TOOLS REQUIRED



99-6501 INSTALLATION INSTRUCTIONS

APPLICATIONS

**CHRYSLER / DODGE / EAGLE / FORD / JEEP
 LINCOLN / MERCURY / PLYMOUTH
 VEHICLES 1974-00
 (SEE INSIDE FOR SPECIFIC APPLICATIONS)**



APPLICATIONS

CHRYSLER

Concorde 1993-97
Cordoba 1975-78
Cordoba 1979-83
E-Class 1983-84
Fifth Avenue 1990-94
Imperial 1982-83
Imperial 1990-94
Laser 1984-86
LeBaron 1976-81
LeBaron 1982-85
LeBaron 1986-94
LeBaron GTS 1985-94
LHS 1993-97
Newport 1980-81
New Yorker 1980-81
New Yorker 1983-87
New Yorker 1988-95
Sebring 1995-99
Town & Country 1990-95
Town & Country 1996-99

DODGE

Aries 1981-89
Aspen 1976-80
Avenger 1995-99
Caravan 1984-90
Caravan 1991-95
Caravan 1996-00
Charger 1974-78
Charger 1983-87
Dakota 1987-96
Dakota 1997-00
Daytona 1984-89
Daytona 1990-93

DODGE (cont.)

Diplomat 1976-89
Durango 1997-00
Dynasty 1988-93
Intrepid 1993-97
Lancer 1985-89
Magnum XE 1978-79
Mirada 1980-83
Neon 1994-99
Omni 1978-82
Pickup 1974-80
Pickup 1981-83
Ram 1994-00
Ramcharger 1974-80
Ramcharger 1981-93
Rampage 1978-82
Shadow 1987-95
Spirit 1989-95
St. Regis 1979-81
Van 1978-97
024 1978-82
400 1982-83
600 1983-87

EAGLE

Vision 1993-97

FORD

Aerostar 1985-91
Bronco II 1984-88
Country Squire 1979-89
Crown Victoria 1983-89
LTD 1979-86
Ranger (mini) 1983-88
Thunderbird 1980-88

JEEP

Cherokee 1997-00
Grand Cherokee 1993-95
Grand Cherokee 1996-98
Wrangler 1997-00

LINCOLN

Continental 1984-88
Mark VII 1984-89

MERCURY

Colony Park 1979-89
Cougar 1983-88
Cougar XR7 1980-82
Grand Marquis 1979-85
Marquis 1979-85

PLYMOUTH

Acclaim 1989-95
Caravelle 1985-87
Fury 1975-78
Gran Fury 1975-85
Horizon 1978-82
Neon 1994-99
Reliant 1981-89
Scamp 1983-84
Sundance 1987-94
TC3 1978-82
Trailduster 1974-80
Trailduster 1981
Turismo 1983-87
Van 1978-97
Volare 1976-80
Voyager 1984-90
Voyager 1991-95
Voyager 1996-99

FORD / LINCOLN / MERCURY vehicles

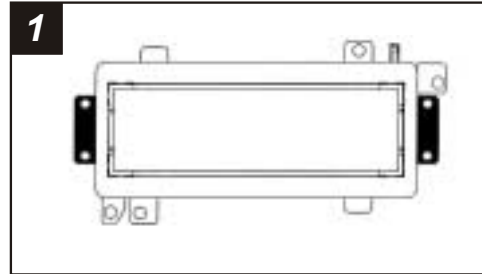

Please call Metra's Technical Support line for individual dash disassemblies.

Cut and remove all mounting tabs on the **Radio Housing** EXCEPT the shaded tabs. Skip to the Installation Instructions for ALL VEHICLES on Page #2.

CHRYSLER Sebring 1995-99 / DODGE Avenger 1995-99 JEEP Grand Cherokee 1993-95

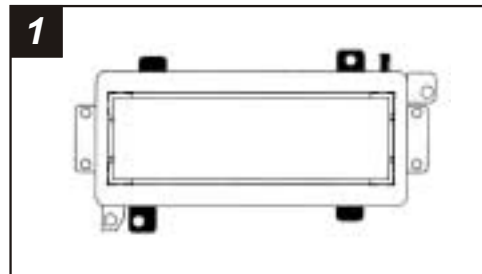

Please call Metra's Technical Support line for individual dash disassemblies.

Cut and remove all mounting tabs on the **Radio Housing** EXCEPT the shaded tabs. Skip to the Installation Instructions for ALL VEHICLES on Page #2.

CHRYSLER/DODGE/EAGLE/JEEP/PLYMOUTH vehicles (EXCEPT Grand Cherokee 1993-95, Sebring, and Avenger)

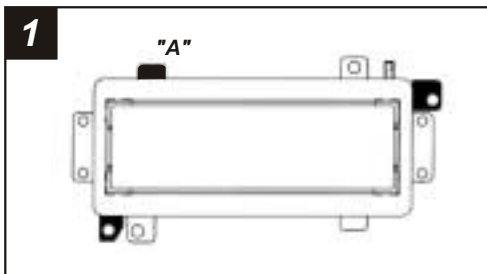

Please call Metra's Technical Support line for individual dash disassemblies.

Cut and remove all mounting tabs on the **Radio Housing** EXCEPT the shaded tabs. (It may be necessary to trim tabs "A" for some applications). Skip to the Installation Instructions for ALL VEHICLES on Page #2.

ALL VEHICLES

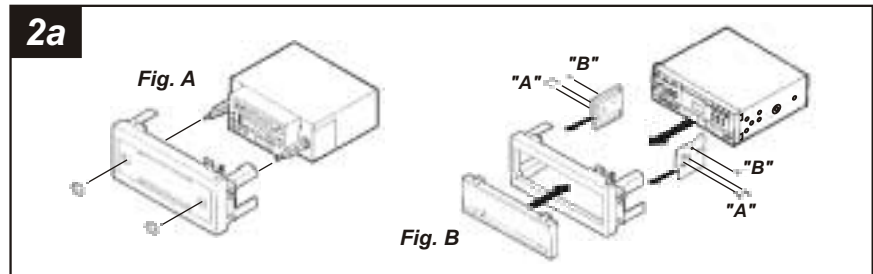

2-SHAFT HEAD UNITS: Attach the **2-Shaft Faceplate** and **Shaft Masks** to the **Radio Housing**. Slide the aftermarket head unit into the kit and secure with shaft nuts. (see Fig. A)

ISO-DIN HEAD UNITS: Snap the **ISO-DIN Faceplate** into the **Radio Housing**. Slide the aftermarket head unit into the back of the kit. Slide the **ISO-DIN Brackets** onto the Housing legs and align the holes in the Brackets with the holes in the unit. Mount the Brackets to the unit with (4) **5mm Flat-head Screws** supplied ("A"). Mount the Brackets to the top of the Housing legs with (2) **#6 Self-tapping Screws** ("B"). (see Fig. B)