

ALL VEHICLES

1

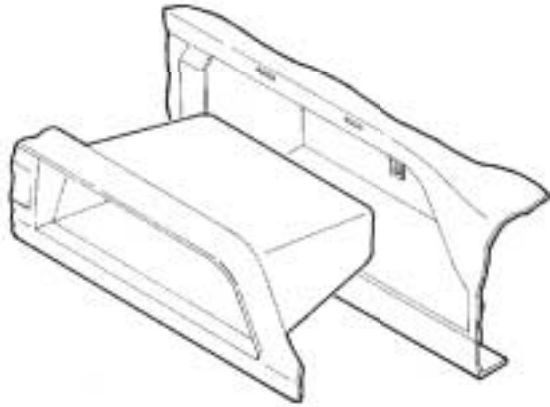

Disconnect the negative battery terminal to prevent an accidental short circuit. Open the glove box and remove (2) Phillips screws securing the right edge of the dash trim bezel. Remove (5) screws from the bottom of the dash trim bezel. Pull out on the upper edge of the bezel and remove.

3

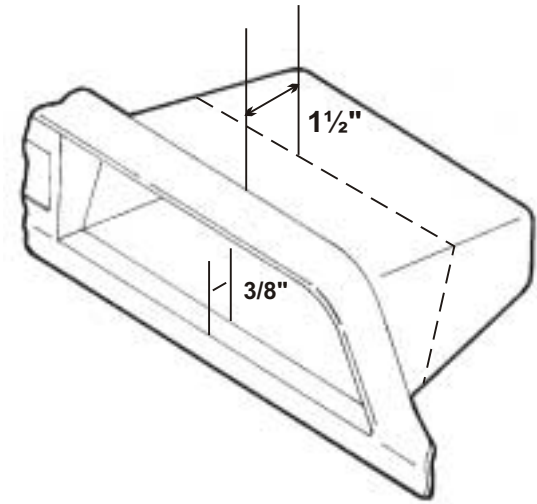

Using the dimensions above, cut and remove the rear portion of the factory pocket from the radio trim bezel.

2

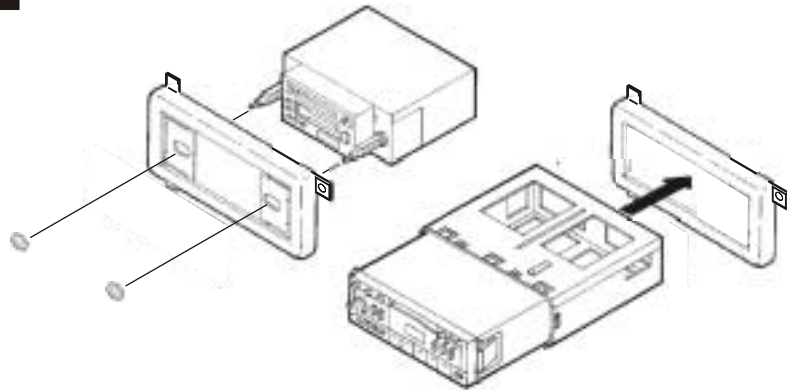

2-SHAFT HEAD UNITS: Slide the aftermarket head unit into the kit and secure with shaft nuts. (see Fig. A)

DIN HEAD UNITS: Cut and remove the shaft supports from the **Radio Housing**. Slide the DIN cage into the kit and secure by bending the metal locking tabs down. Slide the aftermarket head unit into the cage until secure. (see Fig. B)

4

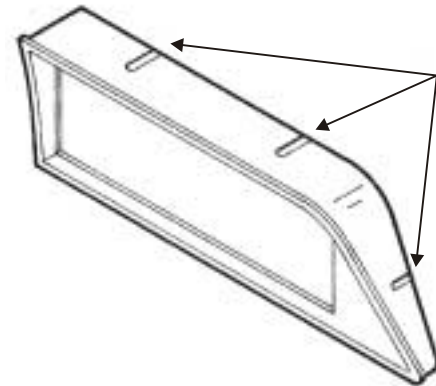

Locate the recessed slots on the top of the **Faceplate** and drill (1) $3/16$ " hole into each slot.

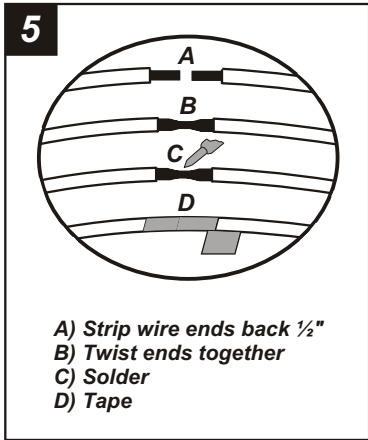

- A) Strip wire ends back 1/2"
- B) Twist ends together
- C) Solder
- D) Tape

Locate the factory wiring harness in the dash. Metra recommends using the proper mating adaptor and making connections as shown. (Isolate and individually tape off the ends of any unused wires to prevent electrical short circuit).

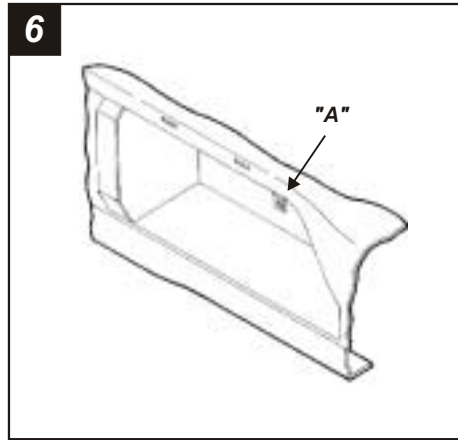

Locate the upper dash tab in the sub-dash and bend the tab down. ("A")

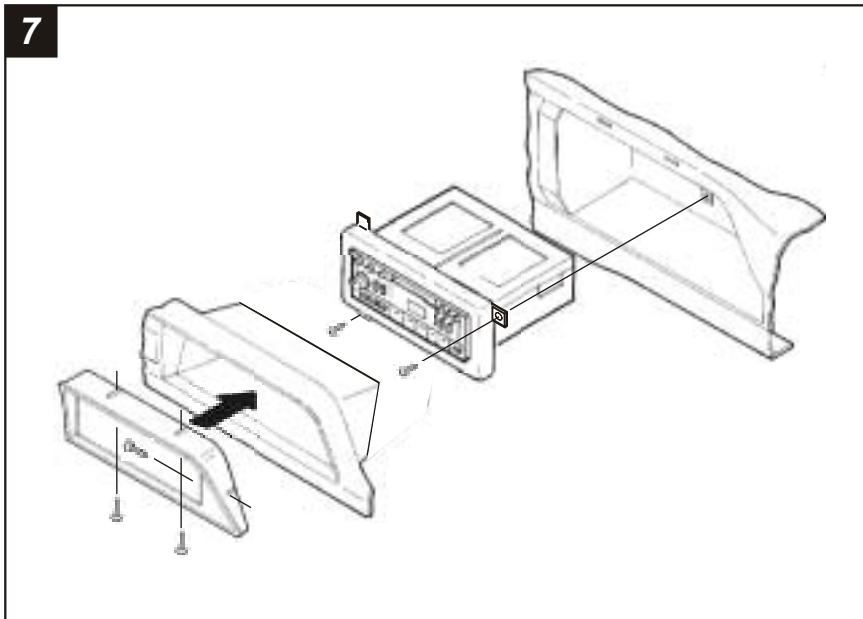

Re-connect the battery terminal and test the unit for proper operation. Mount the head unit/kit assembly to the sub-dash with (2) screws. Place the **Faceplate** into the dash trim bezel and mount with (3) 3/8" **Phillips screws** supplied.

KIT FEATURES

- ▶ Shaft and DIN unit provisions

KIT COMPONENTS

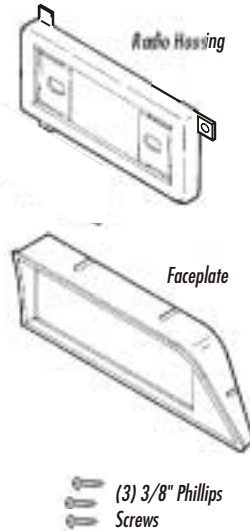

TOOLS REQUIRED



99-6540 INSTALLATION INSTRUCTIONS

APPLICATIONS

CAR	PAGE
DODGE	
Van (full size) 1990-97.....	1-3

