

KIA Santa Fe 2001-2002

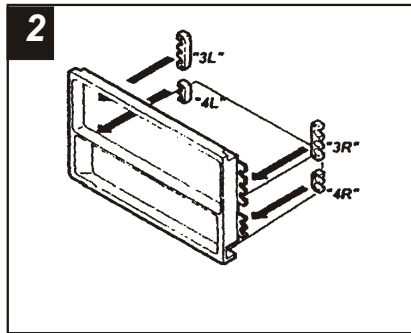

1
Disconnect the negative battery terminal to prevent an accidental short circuit. Remove ashtray and (2) phillips screws exposed in cavity. Unsnap and remove climate controls with caution. The climate controls have (2) clips that connect with the radio bezel. Remove (2) phillips screws now exposed under radio bezel (facing up). Unsnap the bottom of the radio bezel, then the top and pull straight back. Remove (4) phillips screws and remove pocket from bezel. Remove (4) Phillips screws to remove radio from dash.



2
Attach Spacer 3L and 4L to the left mounting tabs of the Radio Housing and Spacer 3R and 4R to the right mounting tabs of the Radio Housing as shown.

All Vehicles

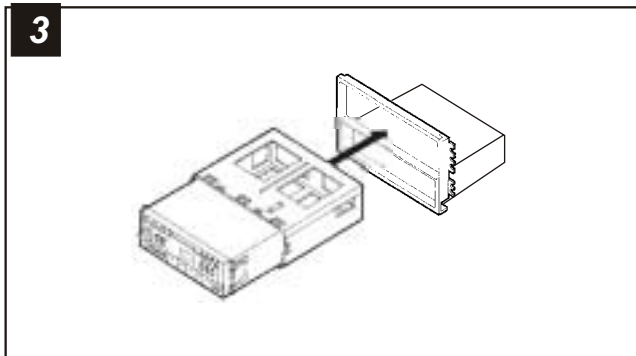

3
Slide the DIN cage into the kit and secure by bending the metal locking tabs down. Slide the aftermarket head unit into the cage until secure.

HYUNDAI Sonata 1995-98

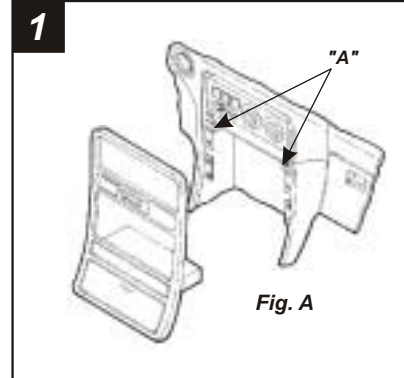

1
Disconnect the negative battery terminal to prevent an accidental short circuit. Unclip the gear shifter trim panel and remove (1) screw exposed. Unclip the dash trim bezel and remove. Remove (4) Phillips screws securing the factory head unit and disconnect the wiring. Cut and remove tabs "A" located in the top corners of the dash cavity.

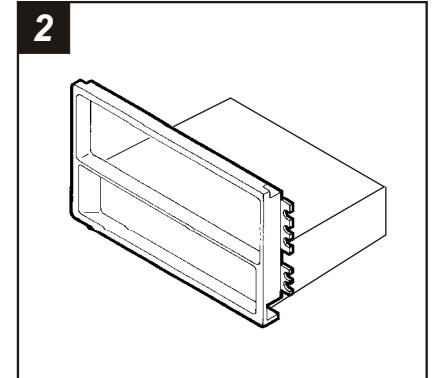

2
Locate the **Radio Housing**. Skip to the *Installation Instructions for ALL VEHICLES on Page #3*.

HYUNDAI Tiburon (double DIN) 1997-02



1
Disconnect the negative battery terminal to prevent an accidental short circuit. Remove (4) Phillips screws securing the center console. Pry out on the front edge of the console and unclip the radio trim bezel. Remove (2) Phillips screws securing the factory pocket and remove. Remove (4) Phillips screws securing the factory head unit and disconnect the wiring.

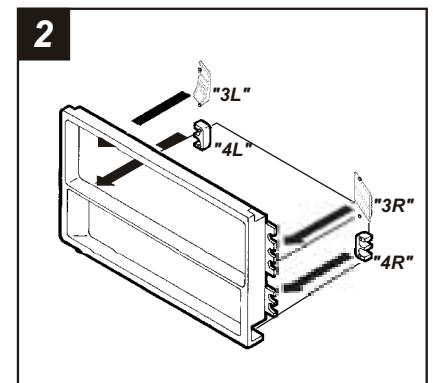

2
Attach **Spacer 3L** and **4L** to the left mounting tabs of the **Radio Housing** and **Spacer 3R** and **4R** to the right mounting tabs of the **Radio Housing** as shown. Skip to the *Installation Instructions for ALL VEHICLES on Page #3*.

HYUNDAI Elantra (double DIN) 1996-00

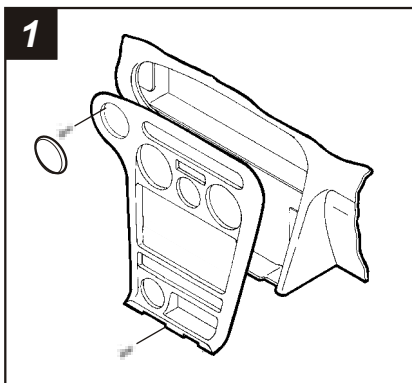

Disconnect the negative battery terminal to prevent an accidental short circuit. Pop out the dimmer switch panel and remove (1) Phillips screw exposed. Unsnap the gear shifter trim plate and remove (1) Phillips screw exposed at the base of the dash trim bezel. Reach under the driver's side dash, locate the temperature control cable and remove the cable from the white plastic bracket. Position the gear shifter in low, pull the dash panel away and disconnect all wiring harnesses. Remove the trim bezel (the temperature control cable will be attached). Remove (4) Phillips screws securing the factory head unit and disconnect the wiring.

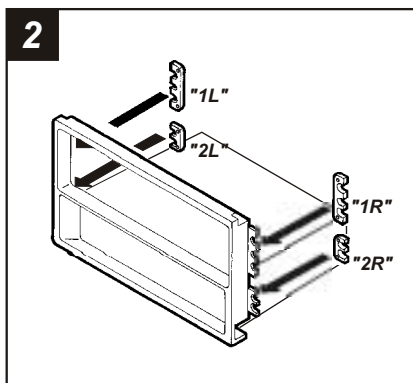

Attach **Spacer 1L** and **2L** to the left mounting tabs of the **Radio Housing** and **Spacer 1R** and **2R** to the right mounting tabs of the **Radio Housing** as shown. Skip to the *Installation Instructions for ALL VEHICLES* on Page #3.

HYUNDAI Sonata 1999-01

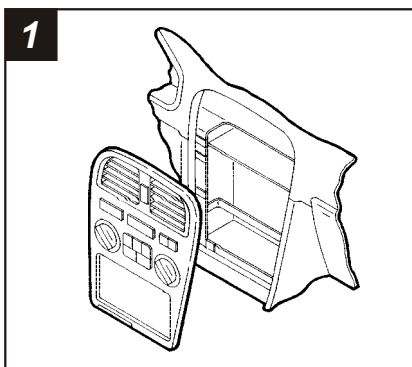

Disconnect the negative battery terminal to prevent an accidental short circuit. Detach the cable located under the left side of the glove box. Unclip the trim piece in front of the gear shifter and remove (2) Phillips screws exposed. Unclip the gear shifter trim and remove (2) Phillips screws exposed. Unclip the radio trim bezel and remove. Remove (6) Phillips screws securing the factory head unit and disconnect the wiring.

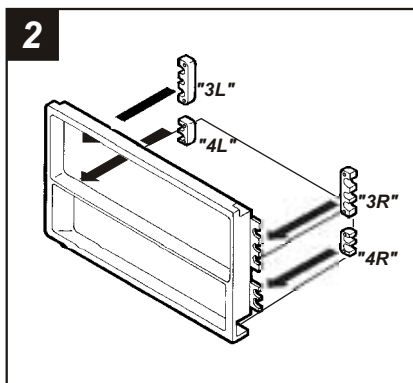

Attach **Spacer 3L** and **4L** to the left mounting tabs of the **Radio Housing** and **Spacer 3R** and **4R** to the right mounting tabs of the **Radio Housing** as shown. Skip to the *Installation Instructions for ALL VEHICLES* on Page #3.

KIT FEATURES

- ▶ DIN head unit provisions
- ▶ CD jewel case pocket (holds 3 jewel cases)

KIT COMPONENTS

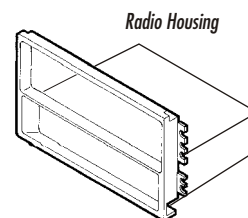

TOOLS REQUIRED



Phillips screwdriver

99-7309

INSTALLATION INSTRUCTIONS

APPLICATIONS

CAR	PAGE
HYUNDAI	
Elantra (double DIN) 1996-00.....	1
Santa Fe 2001-02.....	3
Sonata 1995-98.....	2
Sonata 1999-01.....	1
Tiburon (double DIN) 1997-02.....	2

* Call Metra's Technical Support line for more information

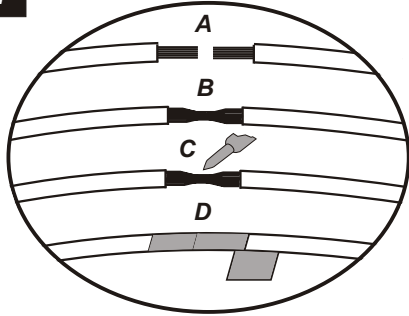

4

- A) Strip wire ends back $\frac{1}{2}$ "
- B) Twist ends together
- C) Solder
- D) Tape

Locate the factory wiring harness in the dash. Metra recommends using the proper mating adaptor and making connections as shown. (Isolate and individually tape off the ends of any unused wires to prevent electrical short circuit).

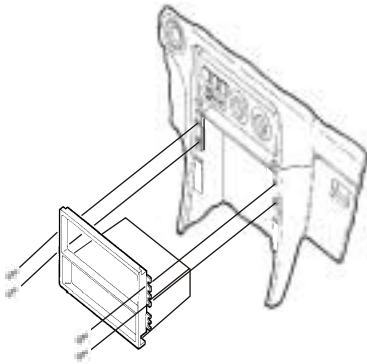
5

Re-connect the battery terminal and test the unit for proper operation. Mount the head unit/kit assembly to the sub-dash with **(4) #10 x $\frac{3}{4}$ " Phillips Truss-head Screws** supplied.