



99-7400 INSTALLATION INSTRUCTIONS

APPLICATIONS

CAR	PAGE
NISSAN	
200SX 1980-83.....	1
200SX 1984-88.....	2
240SX 1989-94.....	3
Axxess 1989-90.....	4
Hardbody Pickup 1986.5-93.....	5
Maxima 1982-84.....	6
Maxima 1987-88.....	7
Maxima 1989-91.....	8
Pathfinder 1987-93.....	5
Pulsar 1983-86.....	9
Pulsar 1987-90.....	10
Sentra 1982-86.....	9
Sentra 1987-90.....	11
Stanza 1982-86.....	12
Stanza 1987-89.....	13

KIT COMPONENTS

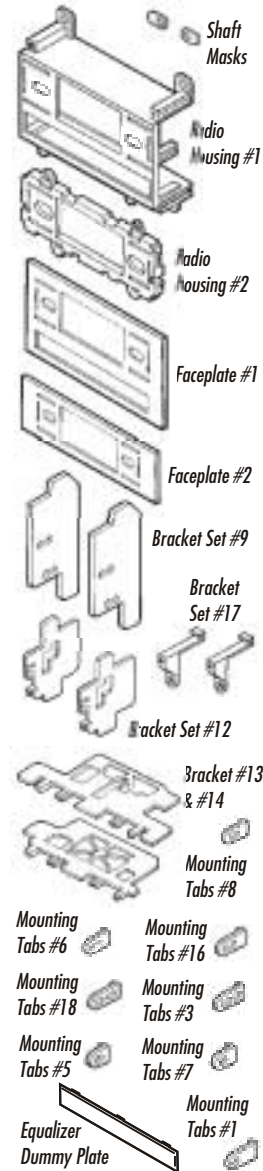

TOOLS REQUIRED



Phillips screwdriver



Cutting tool

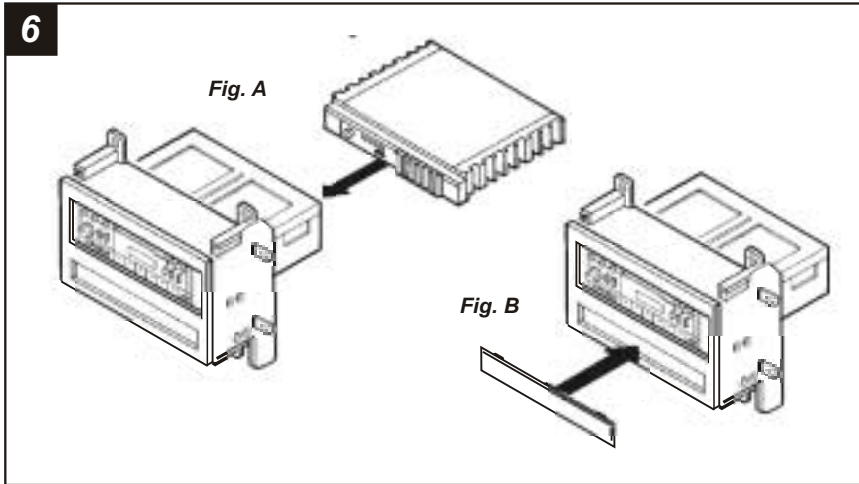

IF AN EQUALIZER WILL BE INCLUDED: Slide the aftermarket equalizer into the back of the kit. Using the hardware included with the equalizer, mount the unit to the kit. (see Fig. A)

IF AN EQUALIZER WILL NOT BE INCLUDED: Snap the **Equalizer Dummy Plate** into the opening in the kit. (see Fig. B)

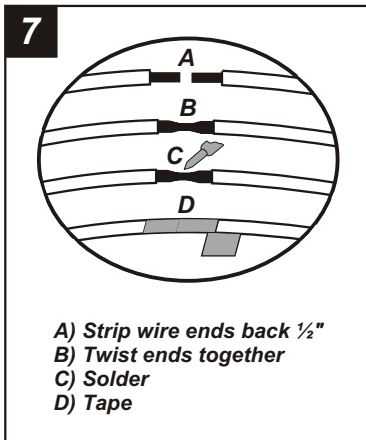

- A) Strip wire ends back 1/2"
- B) Twist ends together
- C) Solder
- D) Tape

Locate the factory wiring harness in the dash. Metra recommends using the proper mating adaptor and making connections as shown. (Isolate and individually tape off the ends of any unused wires to prevent electrical short circuit).

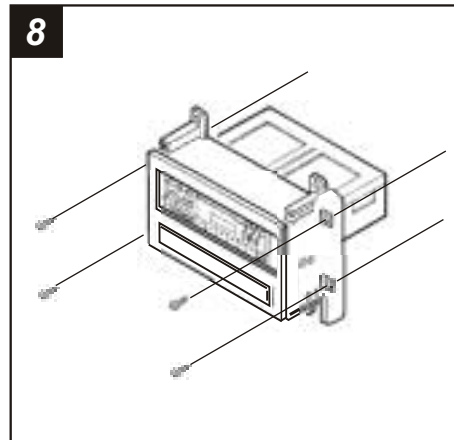

Re-connect the battery terminal and test the unit for proper operation. Mount the head unit/kit assembly to the sub-dash with those screws previously removed in step #1.

NISSAN 200SX 1980-83

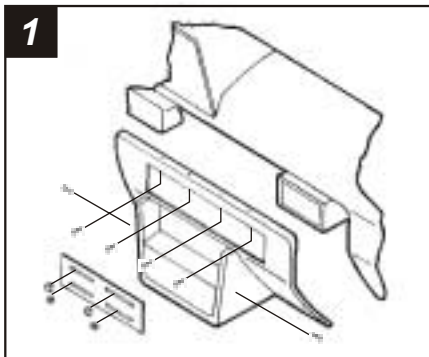

Disconnect the negative battery terminal to prevent an accidental short circuit. Remove (4) Phillips screws above the radio opening. Remove (1) Phillips screw below the left side of the radio opening. Remove (1) Phillips screw from each side of the dash trim bezel. Pull off the climate control knobs and remove the climate control trim panel. Remove the ashtray and lift the dash trim bezel off. Remove the (4) Phillips screws securing the factory head unit and disconnect the wiring.

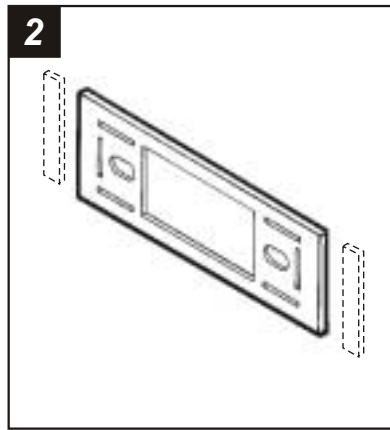

Using the scored lines as a guide, cut and remove the *dashed* portions of **Faceplate #2**.

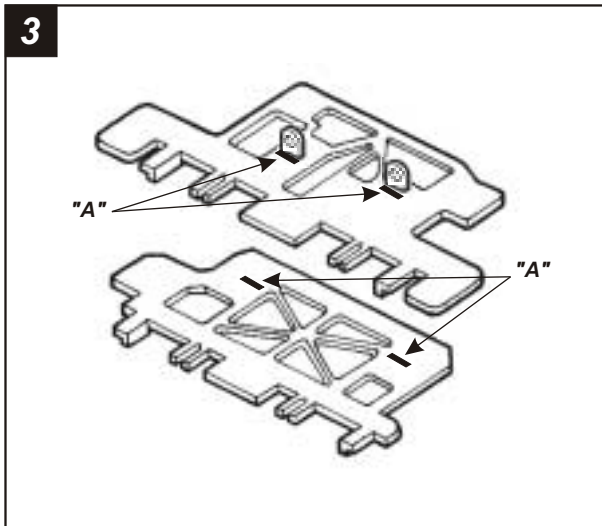

Slide **Mounting Tabs #5** into slots **"A"** on **Brackets #13** and **#14**. The Mounting Tabs, Brackets and Bracket slots can be identified by the stamped letter on each component. *Skip to the Installation Instructions for ALL VEHICLES on Page #14.*

ALL VEHICLES

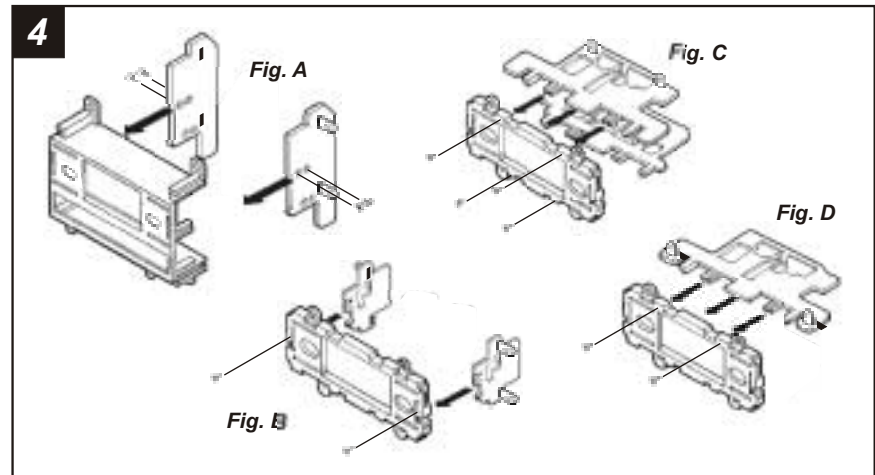

MAXIMA 1987-91, PULSAR 1987-90, STANZA 1987-89, 240SX: Mount **Bracket Set #9** to **Radio Housing #1** with (4) **Phillips Pan-head Screws** supplied. (see Fig. A)

SENTRA 1987-90: Mount **Bracket Set #12** to **Radio Housing #2** with (2) **Phillips Pan-head Screws** supplied. (see Fig. B).

STANZA 1982-86, 200SX, HARDBODY PICKUP, PATHFINDER: Mount **Bracket #13** and **#14** to **Radio Housing #2** with (4) **Phillips Pan-head Screws** supplied. (see Fig. C)

MAXIMA 1982-84: Mount **Bracket #14** to **Radio Housing #2** with (2) **Phillips Pan-head Screws** supplied. (see Fig. D)

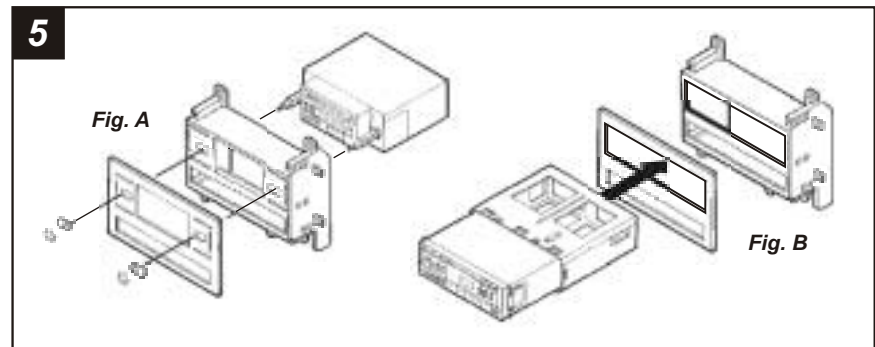

2-SHAFT HEAD UNITS: Snap the Faceplate onto the front of the Radio Housing. Slide the aftermarket head unit into the kit and secure with shaft nuts. (see Fig. A)

DIN HEAD UNITS: Cut and remove the shaft supports from the Faceplate and Radio Housing. Snap the Faceplate onto the front of the Housing. Slide the DIN cage into the kit and secure by bending the metal locking tabs down. Slide the aftermarket head unit into the cage until secure. (see Fig. B)

NISSAN Stanza 1987-89

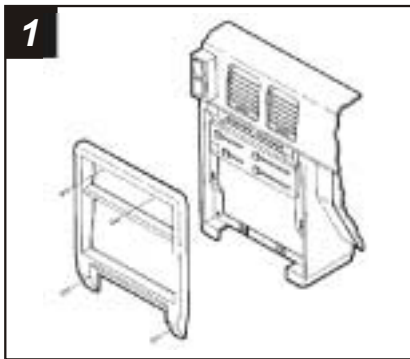

1
Disconnect the negative battery terminal to prevent an accidental short circuit. Remove the ashtray and (2) screws exposed at the base of the dash trim bezel. Remove (2) screws above the climate controls and unclip the bezel. Remove (4) screws securing the factory head unit and disconnect the wiring.

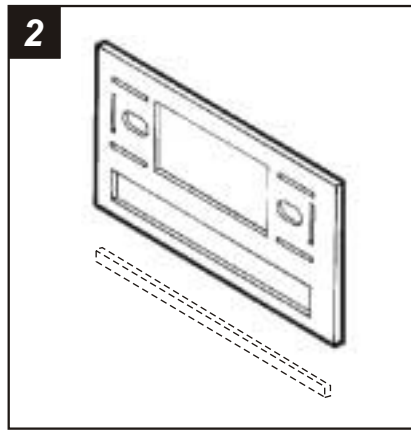

2
Using the scored lines as a guide, cut and remove the dashed portions of **Faceplate #1**.

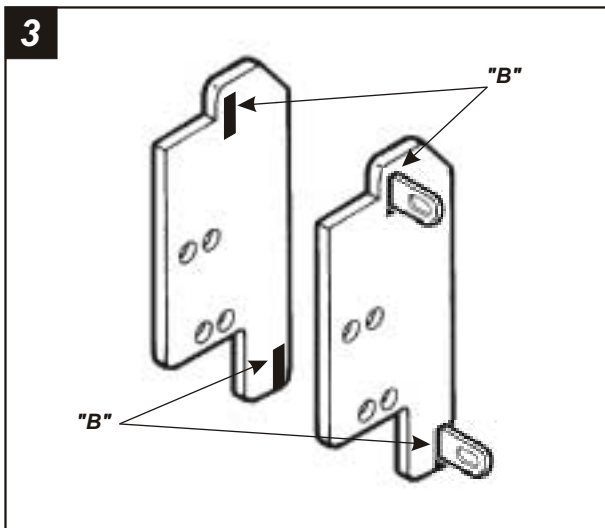

3
Slide **Mounting Tabs #8** into slots **"B"** on **Bracket Set #9**. The Mounting Tabs, Bracket and Bracket slots can be identified by the stamped letter on each component. *Skip to the Installation Instructions for ALL VEHICLES on Page #14.*

NISSAN 200SX 1984-88

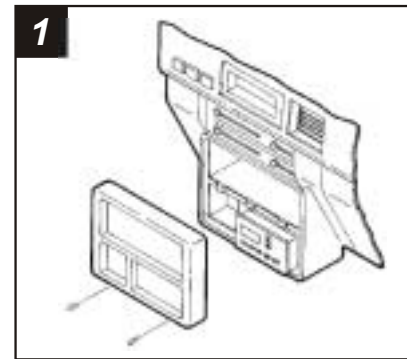

1
Disconnect the negative battery terminal to prevent an accidental short circuit. Remove (1) #10 Phillips screw from each side of the center console. Unsnap the coin tray and remove (2) #10 Phillips screws exposed. Lift the storage box carpet out and remove (2) #10 Phillips screws exposed. Remove the ashtray and (2) #8 Phillips screws exposed. Remove the dash trim bezel. Remove (4) screws securing the factory head unit and disconnect the wiring.

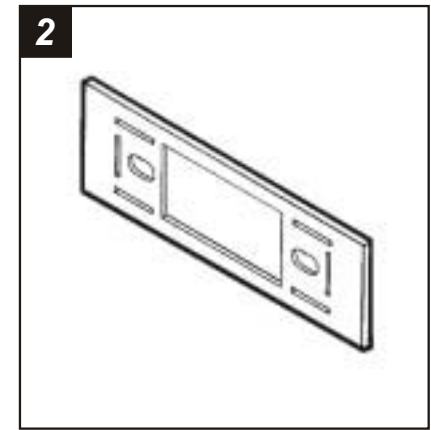

2
Locate **Faceplate #2**. (It is NOT necessary to cut the Faceplate).

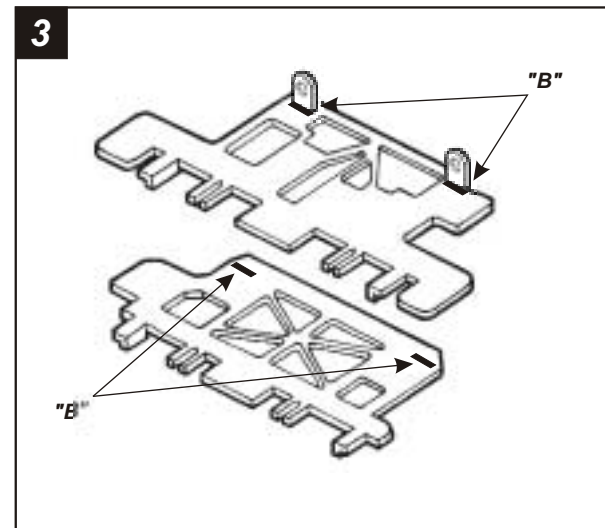

3
Slide **Mounting Tabs #8** into slots **"B"** on **Brackets #13 and #14**. The Mounting Tabs, Brackets and Bracket slots can be identified by the stamped letter on each component. *Skip to the Installation Instructions for ALL VEHICLES on Page #14.*

NISSAN 240SX 1989-94

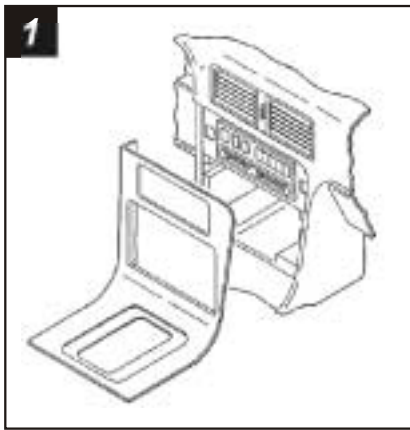

Disconnect the negative battery terminal to prevent an accidental short circuit. Unclip the dash trim bezel and remove. Remove (4) Phillips screws securing the factory head unit and disconnect the wiring.

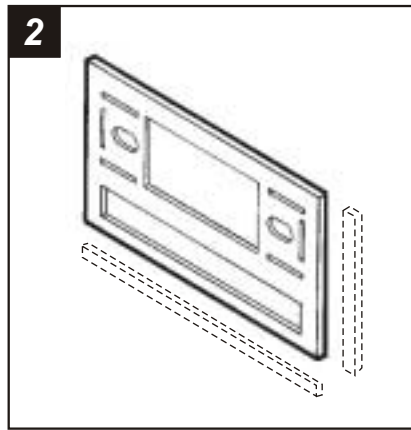

Using the scored lines as a guide, cut and remove the *dashed* portions of **Faceplate #1**.

NISSAN Stanza 1982-86

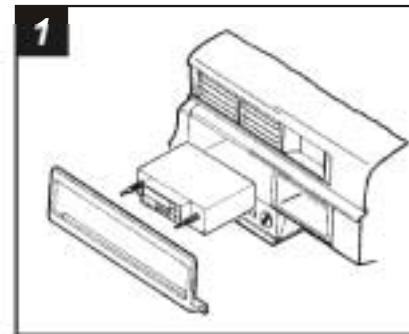

Disconnect the negative battery terminal to prevent an accidental short circuit. Remove (3) screws from the top of the dash trim bezel. Remove (1) screw from each side of the ashtray housing. Remove (3) screws from the factory dummy plate. (The factory pocket will remain intact).

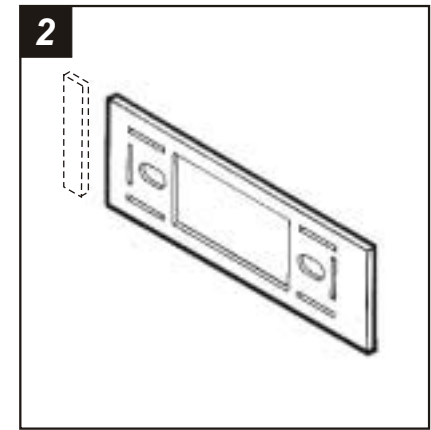

Using the scored lines as a guide, cut and remove the *dashed* portions of **Faceplate #2**.

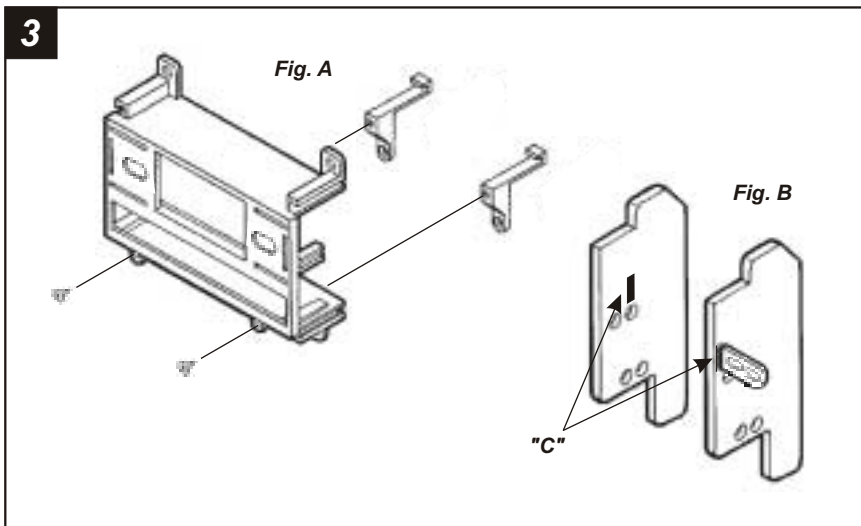

Align **Bracket Set #17** with the lower mounting positions on **Radio Housing #1**, slide the Brackets over the bottom shelf of the Housing and secure with (2) **Phillips Pan-head Screws** supplied. (see Fig. A). Slide **Mounting Tabs #18** into slots "C" on **Bracket Set #9**. (see Fig. B). The Mounting Tabs, Brackets and Bracket slots can be identified by the stamped letter on each component. Skip to the Installation Instructions for ALL VEHICLES on Page #14.

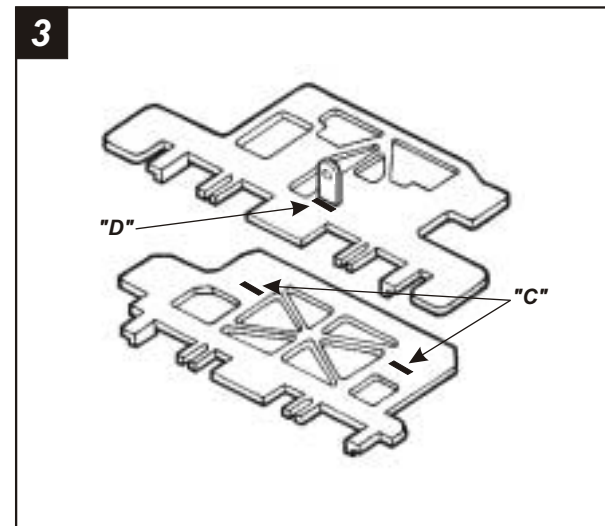

Slide **Mounting Tab #1** into slot "D" on **Bracket #14**. Slide **Mounting Tabs #8** into slots "C" on **Bracket #13**. The Mounting Tabs, Brackets and Bracket slots can be identified by the stamped letter on each component. Skip to the Installation Instructions for ALL VEHICLES on Page #14.

NISSAN Sentra 1987-90

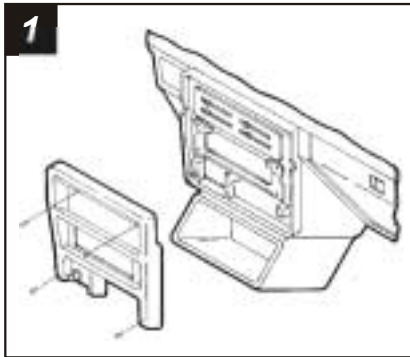

1
Disconnect the negative battery terminal to prevent an accidental short circuit. Remove the ashtray. Remove (2) screws above the climate controls. Remove (2) screws from the base of the dash trim bezel and remove the bezel. Remove the screws securing the factory head unit and disconnect the wiring.

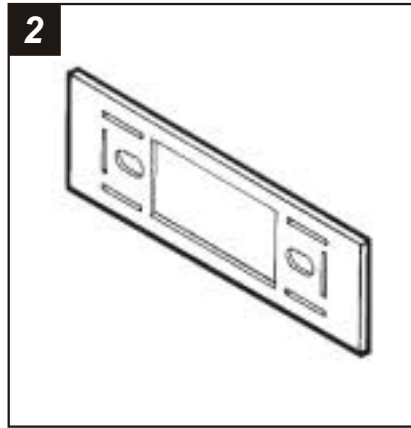

2
Locate **Faceplate #2**. (It is NOT necessary to cut the Faceplate).

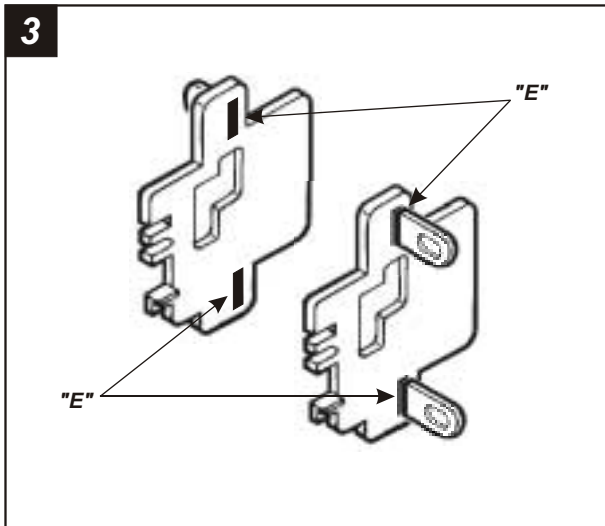

3
Slide **Mounting Tabs #8** into slots "**E**" on **Bracket Set #12**. The Mounting Tabs, Bracket and Bracket slots can be identified by the stamped letter on each component. Skip to the Installation Instructions for ALL VEHICLES on Page #14.

NISSAN Axxess 1989-90

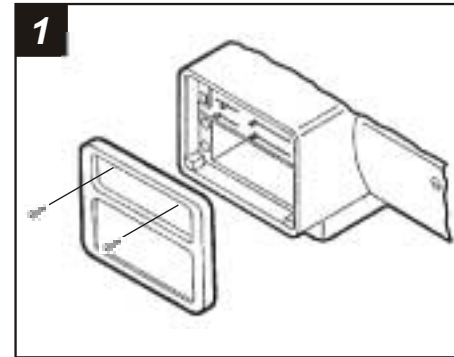

1
Disconnect the negative battery terminal to prevent an accidental short circuit. Remove (2) screws from the top of the dash trim bezel and remove the bezel. Remove (4) fasteners from the factory head unit and disconnect the wiring.

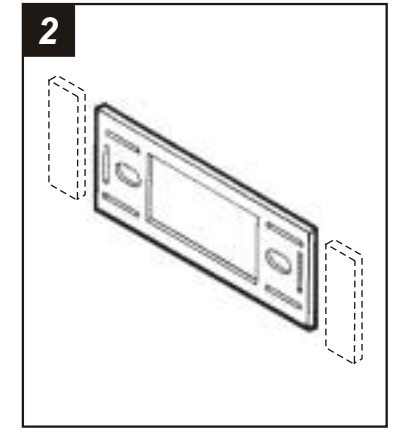

2
Using the scored lines as a guide, cut and remove the *dashed* portions of **Faceplate #1**.

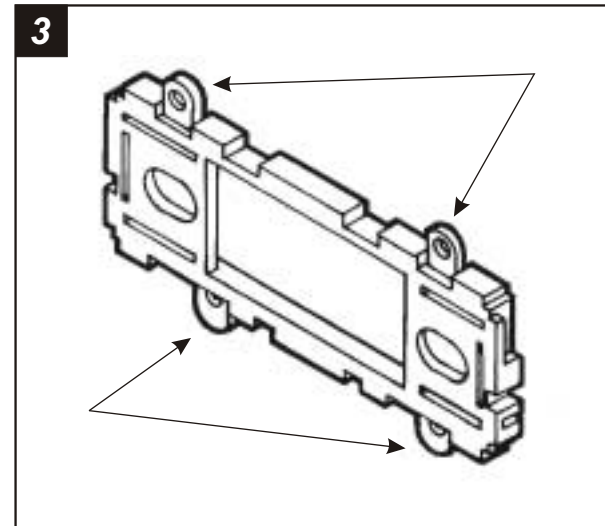

3
Locate **Radio Housing #2** and use the attached mounting tabs during the installation in step #8. (It is NOT necessary to mount Brackets to the Housing). Skip to the Installation Instructions for ALL VEHICLES on Page #14.

NISSAN Hardbody Pickup / Pathfinder 1986 1/2-93

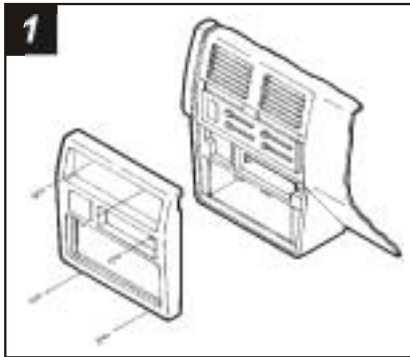

Disconnect the negative battery terminal to prevent an accidental short circuit. Remove the ashtray and (1) screw exposed in the top-right corner. Remove (2) Phillips screws above the climate controls. Remove (2) Phillips screws from the bottom of the dash trim bezel. Unsnap the bezel and disconnect the cigarette lighter wiring. Remove (4) screws securing the factory head unit and disconnect the wiring.

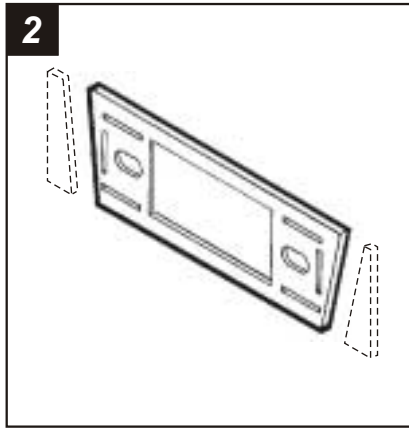

Using the scored lines as a guide, cut and remove the *dashed* portions of **Faceplate #2**.

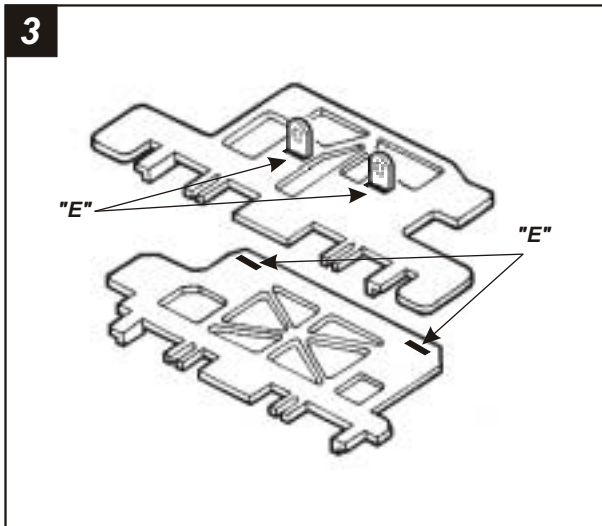

Slide **Mounting Tabs #8** into slots "**E**" on **Brackets #13** and **#14**. The Mounting Tabs, Brackets and Bracket slots can be identified by the stamped letter on each component. *Skip to the Installation Instructions for ALL VEHICLES on Page #14.*

NISSAN Pulsar 1987-90

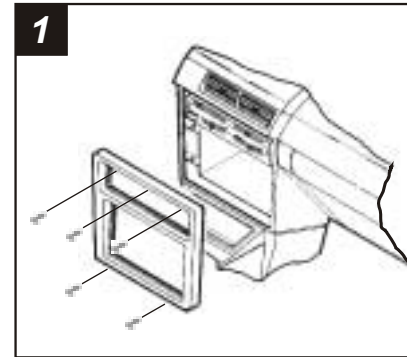

Disconnect the negative battery terminal to prevent an accidental short circuit. Remove (3) screws above the climate controls. Remove (2) screws from the bottom edge of the dash trim bezel. Unclip the bezel and remove. Remove (4) screws securing the factory head unit and disconnect the wiring.

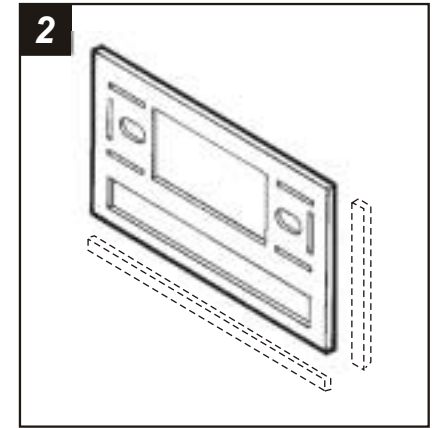

Using the scored lines as a guide, cut and remove the *dashed* portions of **Faceplate #1**.

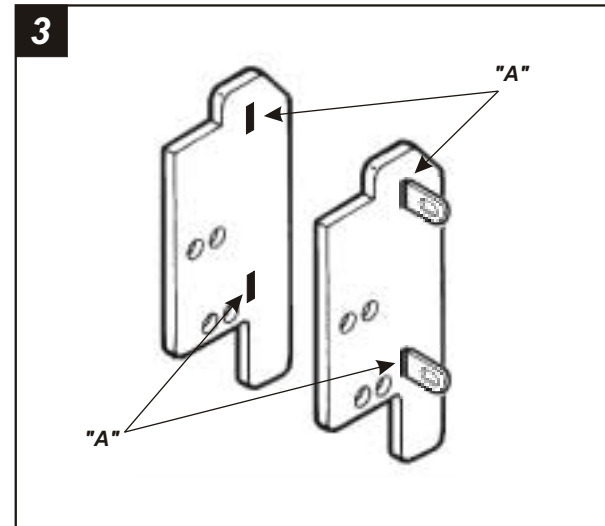

Slide **Mounting Tabs #8** into slots "**A**" on **Bracket Set #9**. The Mounting Tabs, Brackets and Bracket slots can be identified by the stamped letter on each component. *Skip to the Installation Instructions for ALL VEHICLES on Page #14.*

NISSAN Pulsar 1983-86 / Sentra 1982-86

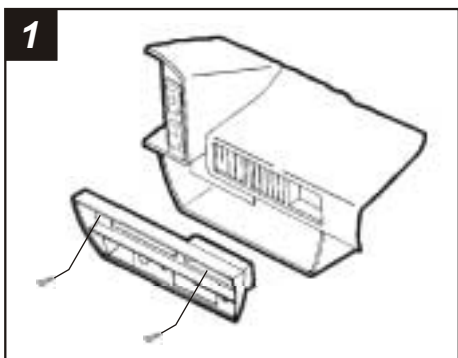

1
Disconnect the negative battery terminal to prevent an accidental short circuit. Remove (2) Phillips screws from the top of the dash trim bezel. Remove the ashtray and (1) screw exposed on the ashtray bracket. Remove the bracket. Unclip the dash trim bezel and disconnect the wiring. Remove (2) Phillips screws securing the factory head unit to the shelf. Remove the unit and disconnect the wiring.

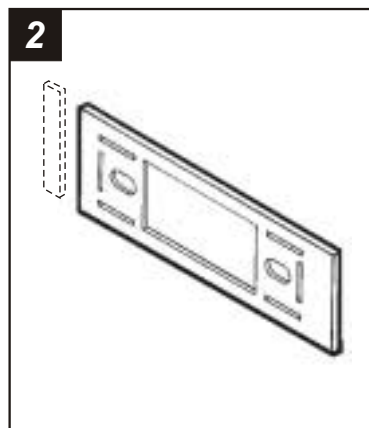

2
Using the scored lines as a guide, cut and remove the *dashed* portions of **Faceplate #2**. (This model does NOT require the use of a Radio Housing or Mounting Brackets).

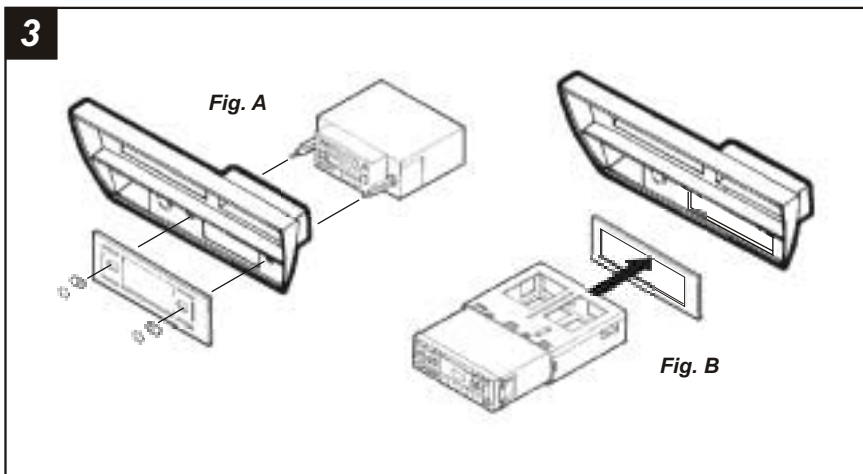

3
2-SHAFT HEAD UNITS: Slide the aftermarket head unit into the dash trim bezel, place the Faceplate and **Shaft Masks** over the radio shafts and secure with shaft nuts. (see Fig. A). Make wiring connections and re-attach the dash trim bezel.

DIN HEAD UNITS: Cut and remove the shaft supports from the Faceplate. Cut a DIN opening in the dash trim bezel. Slide the DIN cage through the Faceplate into the dash trim bezel and secure by bending the metal locking tabs down. Make wiring connections and slide the aftermarket head unit into the cage until secure. (see Fig. B). Re-attach the dash trim bezel.

NISSAN Maxima 1982-84

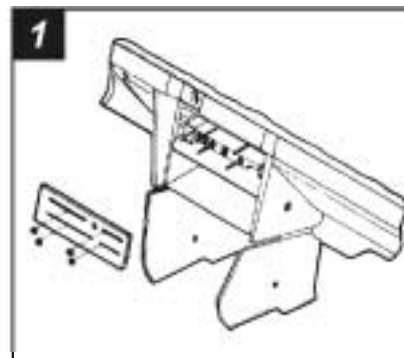

1
Disconnect the negative battery terminal to prevent an accidental short circuit. Remove the knobs from the climate controls. Using a small screwdriver, pry out on the climate control trim panel and remove. Remove (2) screws securing the factory dummy plate and discard the plate.

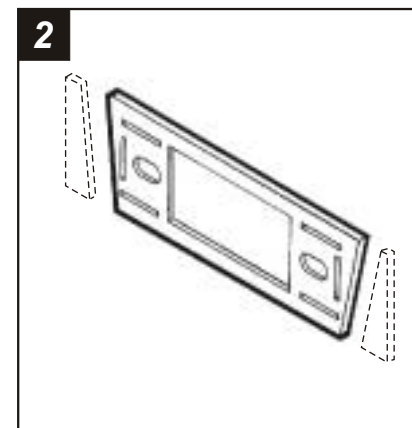

2
Using the scored lines as a guide, cut and remove the *dashed* portions of **Faceplate #2**.

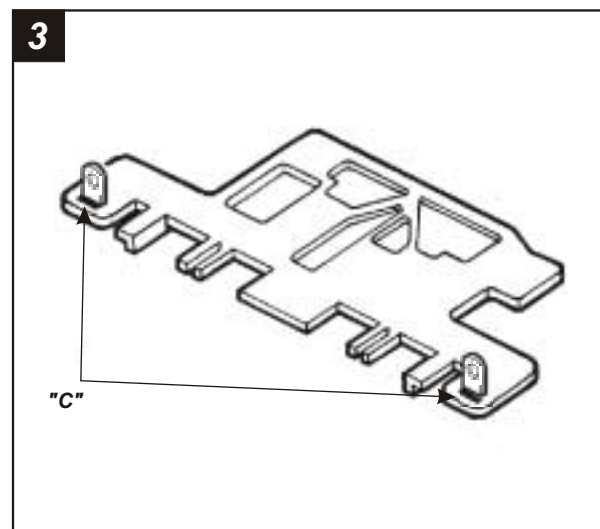

3
Slide **Mounting Tabs #8** into slots "C" on **Bracket Set #14**. The Mounting Tabs, Bracket and Bracket slots can be identified by the stamped letter on each component. Skip to the Installation Instructions for ALL VEHICLES on Page #14.

NISSAN Maxima 1987-88

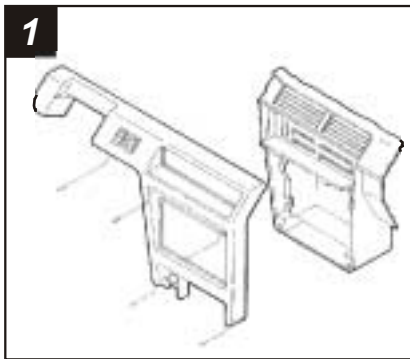

1
Disconnect the negative battery terminal to prevent an accidental short circuit. Remove (2) Phillips screws from the bottom of the dash trim bezel. Remove (2) Phillips screws above the radio opening. Unclip the dash trim bezel and disconnect the defroster and rear wiper wiring. Remove (4) screws securing the factory head unit and disconnect the wiring.

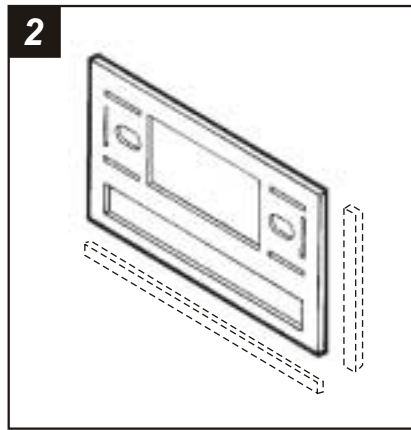

2
Using the scored lines as a guide, cut and remove the *dashed* portions of **Faceplate #1**.

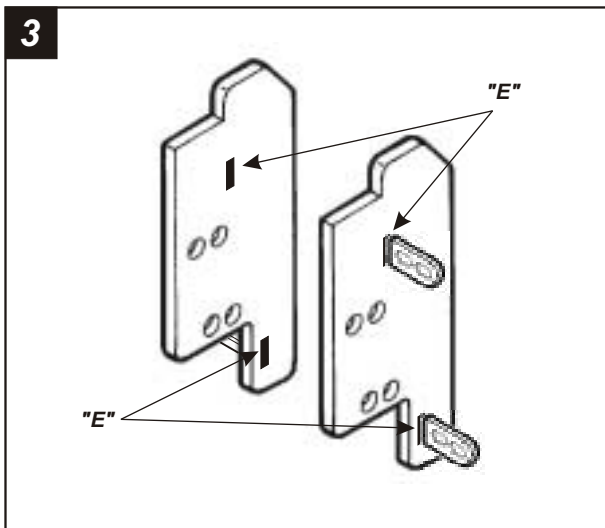

3
Slide **Mounting Tabs #18** into slots "**E**" on **Bracket Set #9**. The Mounting Tabs, Bracket and Bracket slots can be identified by the stamped letter on each component. *Skip to the Installation Instructions for ALL VEHICLES on Page #14.*

NISSAN Maxima 1989-91

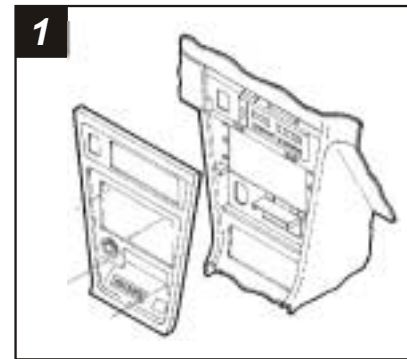

1
Disconnect the negative battery terminal to prevent an accidental short circuit. Remove (2) Phillips screws above the radio opening. Remove the ashtray and (1) screw in the right corner of the ashtray housing. Remove (1) screw below the cigarette lighter and unclip the dash trim bezel. Remove (4) screws securing the factory head unit and disconnect the wiring.

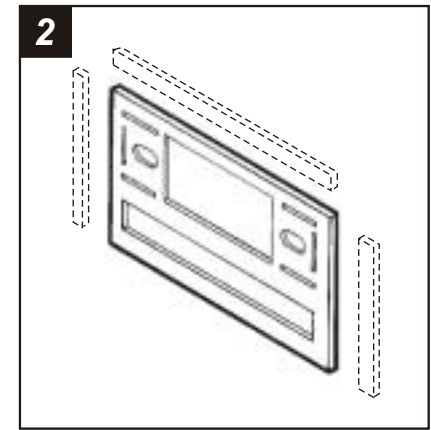

2
Using the scored lines as a guide, cut and remove the *dashed* portions of **Faceplate #1**.

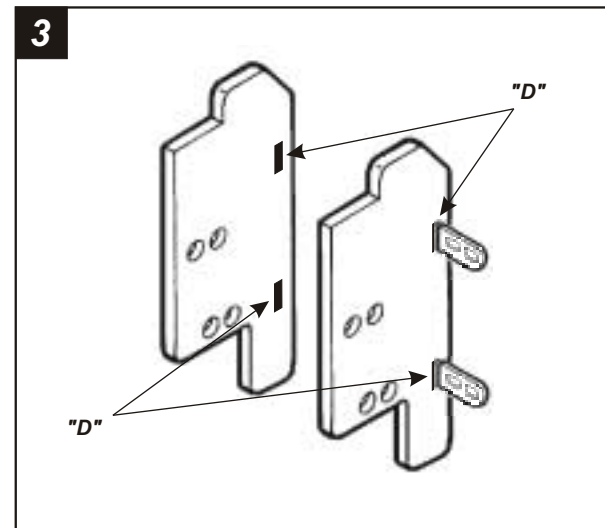

3
Slide **Mounting Tabs #18** into slots "**D**" on **Brackets #9**. The Mounting Tabs, Brackets and Bracket slots can be identified by the stamped letter on each component. *Skip to the Installation Instructions for ALL VEHICLES on Page #14.*