

MERCURY Villager / NISSAN Quest 1993-95

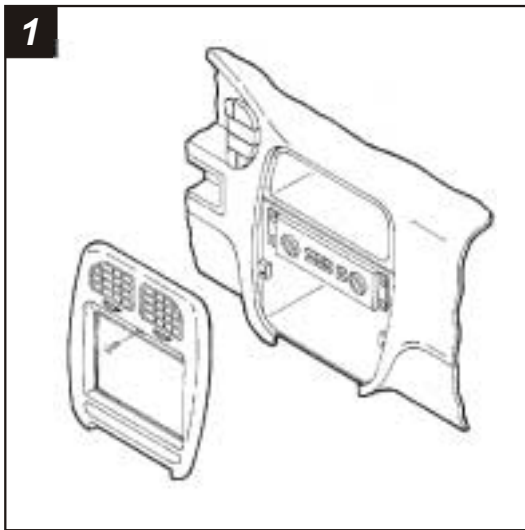

Disconnect the negative battery terminal to prevent an accidental short circuit. Remove (1) screw above the climate controls. Unclip the radio trim bezel and remove. Remove (4) Phillips screws securing the factory radio housing and remove the housing. Disconnect the wiring. Remove (8) Phillips screws securing the factory radio to the factory radio housing and remove the radio. *Skip to the Installation Instructions for ALL VEHICLES on Page #2.*

ALL VEHICLES

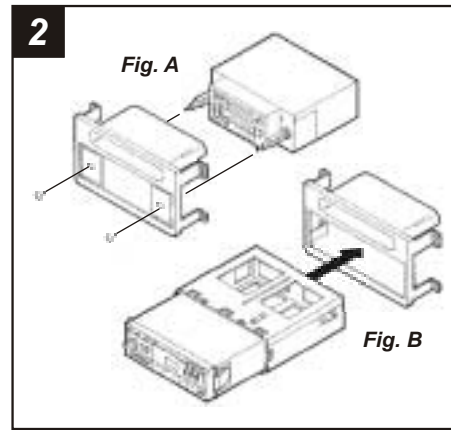

2-SHAFT HEAD UNITS: Slide the aftermarket head unit into the **Radio Housing** and secure with shaft nuts. (see Fig. A)

DIN HEAD UNITS: Cut and remove the shaft supports. Slide the DIN cage into the **Radio Housing** and secure by bending the metal locking tabs down. Slide the aftermarket head unit into the cage until secure. (see Fig. B)

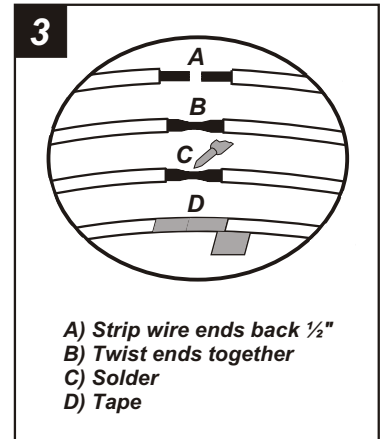

Locate the factory wiring harness in the dash. Metra recommends using the proper mating adaptor and making connections as shown. (Isolate and individually tape off the ends of any unused wires to prevent electrical short circuit).

MERCURY Villager / NISSAN Quest 1996-98

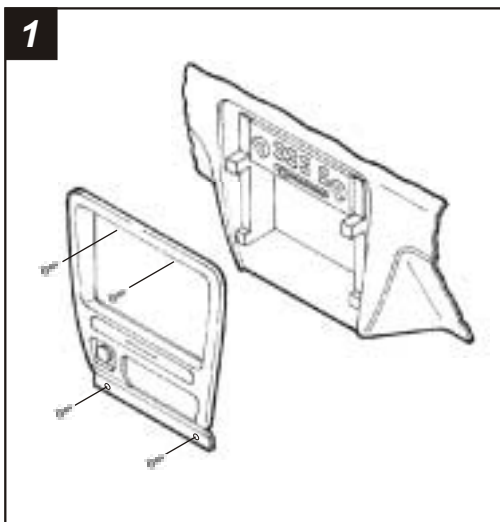

Disconnect the negative battery terminal to prevent an accidental short circuit. Remove (4) plastic screws from the base of the storage compartment. Pop out (4) anchor clips (securing the screws) and remove the compartment. Remove (2) Phillips screws from the base of the radio trim bezel. Remove (2) Phillips screws above the radio opening. Remove the ashtray. Pull up and out on the radio trim bezel and remove the bezel. Remove (4) Phillips screws securing the factory radio housing and remove the housing. Disconnect the wiring. Remove (2) Phillips screws securing the factory radio to the housing and remove the radio. *Skip to the Installation Instructions for ALL VEHICLES on Page #2.*

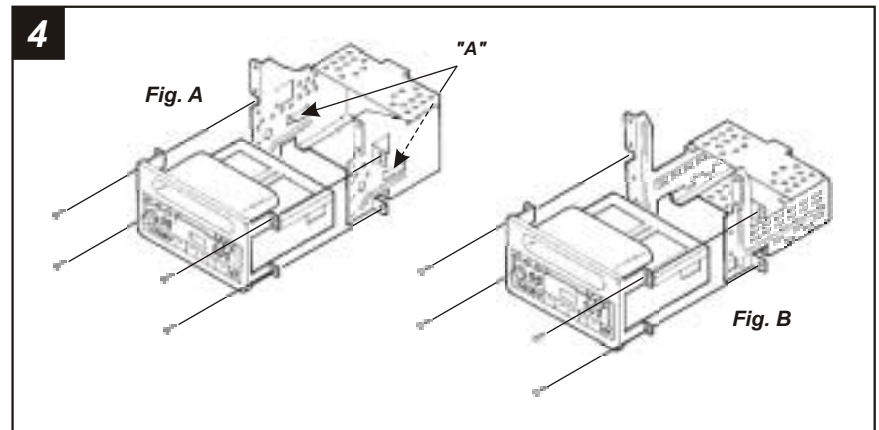

VILLAGER 1993-95, QUEST 1993-95: Bend down tabs "A" on the factory radio housing until they are flush with the walls of the housing. Re-connect the battery terminal and test the unit for proper operation. Mount the head unit/kit assembly to the sub-dash (through the holes in the factory radio housing) with (4) Phillips screws previously removed in step #1. (see Fig. A)

VILLAGER 1996-98, QUEST 1996-98: Re-connect the battery terminal and test the unit for proper operation. Mount the head unit/kit assembly to the sub-dash (through the holes in the factory radio housing) with (4) Phillips screws previously removed in step #1. (see Fig. B)

KIT FEATURES

- ▶ Shaft and DIN unit provisions
- ▶ Pocket provisions

99-7412

INSTALLATION INSTRUCTIONS

KIT COMPONENTS



APPLICATIONS

CAR	PAGE
MERCURY	
Villager 1993-95.....	1-2
Villager 1996-98.....	1-2
NISSAN	
Quest 1993-95.....	1-2
Quest 1996-98.....	1-2

TOOLS REQUIRED



Phillips screwdriver



Cutting tool



Socket wrench

