

KIT FEATURES

- ▶ DIN head unit provisions
- ▶ CD jewel case pocket (holds 2 jewel cases)

KIT COMPONENTS

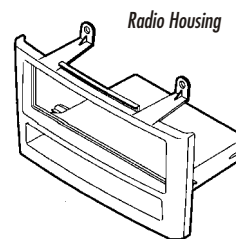

TOOLS REQUIRED



99-7416

INSTALLATION INSTRUCTIONS

APPLICATIONS

<u>CAR</u>	<u>PAGE</u>
NISSAN	
Maxima 2000-02*	1-2

* This kit fits the Bose and Comfort & Convenience packages.



ALL VEHICLES

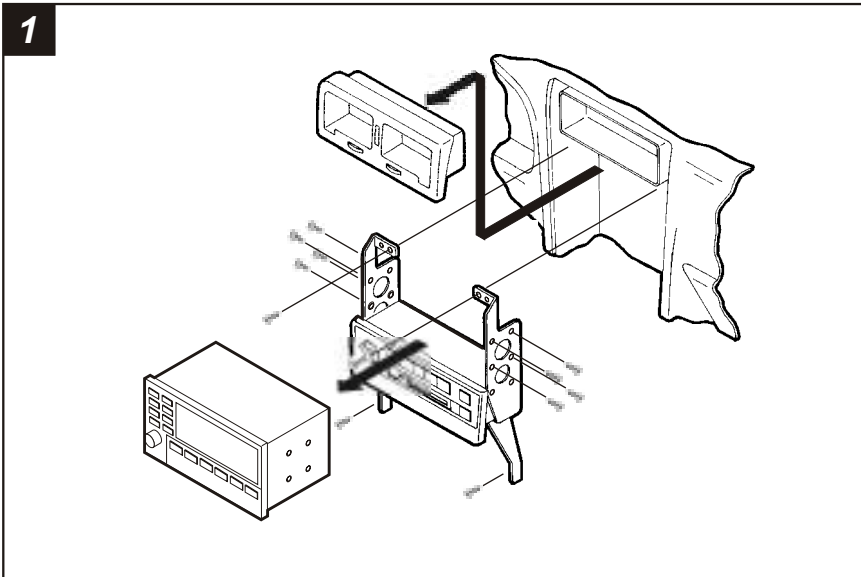

Disconnect the negative battery terminal to prevent an accidental short circuit. Pull out on the climate control trim bezel and remove. Remove (2) Phillips screws exposed at the top of the factory bracket assembly. Remove the ashtray and (1) Phillips screw exposed in the ashtray cavity. Pull up on the gear shifter trim and remove. Unclip the lower dash trim bezel and remove. Remove (2) Phillips screws exposed at the bottom of the factory bracket assembly and remove the assembly from the sub-dash. Remove (8) Phillips screws securing the factory head unit to the bracket assembly and remove the unit.

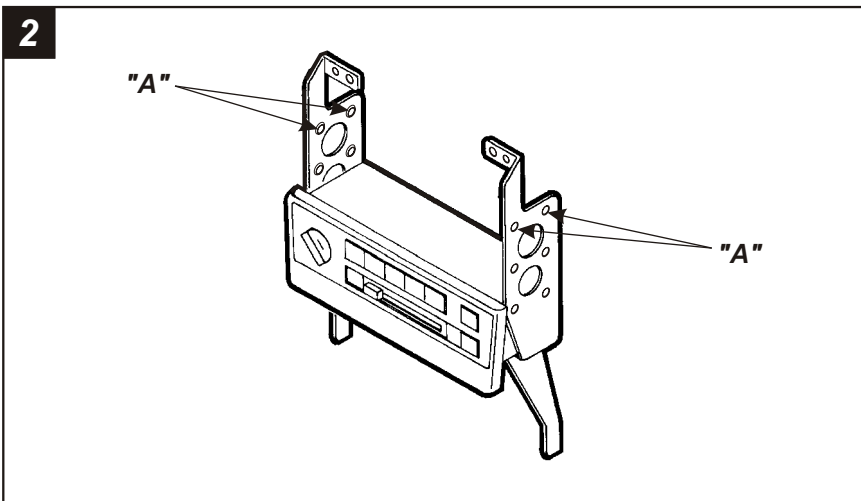

Using a hammer, flatten the protruding screw holes ("A") on the factory brackets.

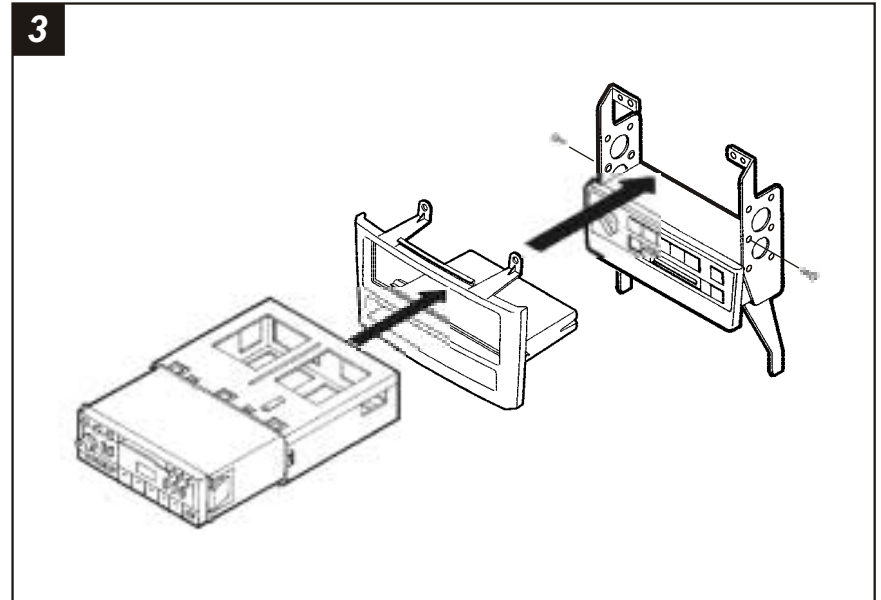

Mount the **Radio Housing** to the factory brackets with (2) #8 x 1/2" Phillips Truss-Head Screws supplied. Slide the DIN cage into the Radio Housing and secure by bending the metal locking tabs down. Slide the aftermarket head unit into the cage until secure.

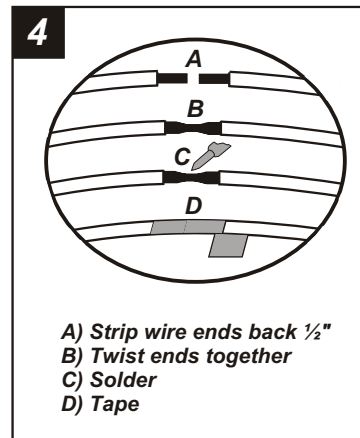

Locate the factory wiring harness in the dash. Metra recommends using the proper mating adaptor and making connections as shown. (Isolate and individually tape off the ends of any unused wires to prevent electrical short circuit).

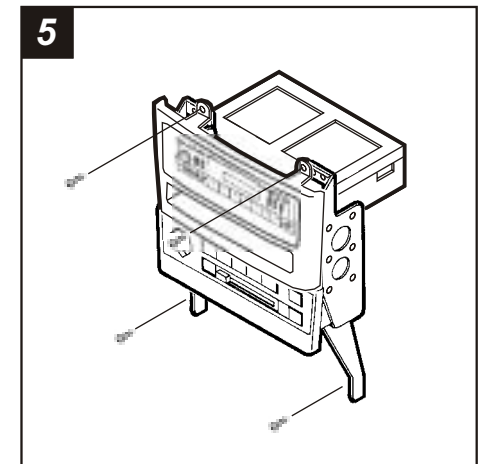

Re-connect the battery terminal and test the unit for proper operation. Mount the factory bracket assembly to the sub-dash with (4) Phillips screws previously removed in step #1.