

KIT FEATURES

- ▶ ISO and DIN unit provisions
- ▶ Pocket (holds 2 jewel cases)

KIT COMPONENTS

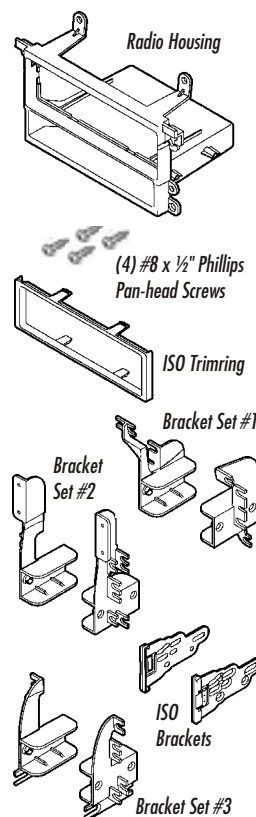

TOOLS REQUIRED



99-7417

INSTALLATION INSTRUCTIONS

APPLICATIONS

CAR	PAGE
INFINITI	
I-30 1996-99.....	9
MERCURY	
Villager 1993-95.....	1
Villager 1996-98.....	1
Villager 1999-02.....	2
NISSAN	
200SX 1995-98.....	2
240SX 1995-98.....	3
Altima 1998-01.....	3
Frontier 1998-01.....	4
Frontier 2002.....	4
Maxima 1995-99.....	5
Maxima 2000-02*.....	5
Pathfinder 1996-00.....	6
Pathfinder 2001-02.....	6
Quest 1993-95.....	7
Quest 1996-98.....	7
Quest 1999-02.....	2
Sentra 1995-99.....	8
Xterra 2000-01.....	8
Xterra 2002.....	4

* Fits all models EXCEPT the Bose and Comfort & Convenience pkgs.

MERCURY Villager 1993-95

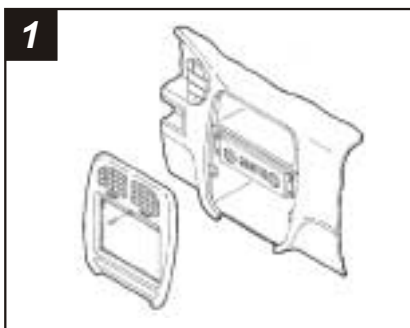

Disconnect the negative battery terminal to prevent an accidental short circuit. Remove (1) screw above the climate controls. Unclip the radio trim bezel and remove. Remove (4) Phillips screws securing the factory radio housing and remove the housing. Disconnect the wiring. Remove (8) Phillips screws securing the factory radio to the factory radio housing and remove the radio.

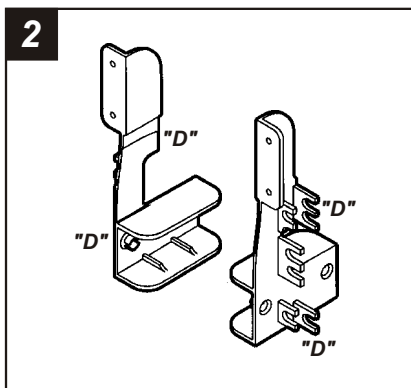

Cut and remove all mounting tabs on **Bracket Set #2** EXCEPT tabs "D". (The tabs can be identified by the stamped letter by each tab). Skip to the *Installation Instructions for ALL VEHICLES on Page #9*.

4

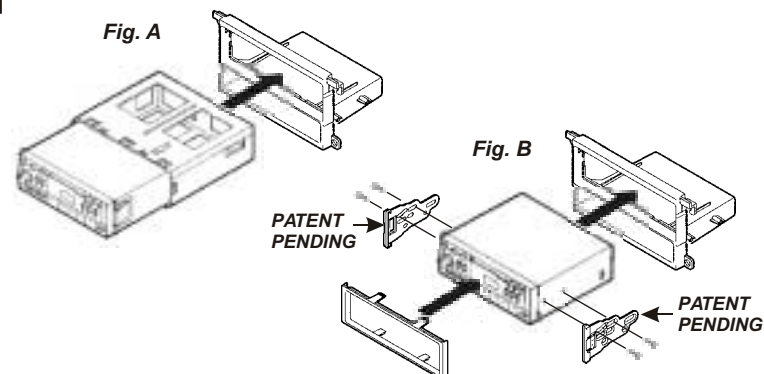

DIN HEAD UNITS: Slide the DIN cage into the kit and secure by bending the metal locking tabs down. Slide the aftermarket head unit into the cage until secure (see Fig. A).

ISO HEAD UNITS: Secure the **ISO Brackets** to the sides of the aftermarket head unit with the screws supplied with the unit. Slide the head unit assembly into the **Radio Housing** until the side clips engage and attach the **ISO Trimming** over the mounted head unit (see Fig. B).

MERCURY Villager 1996-98

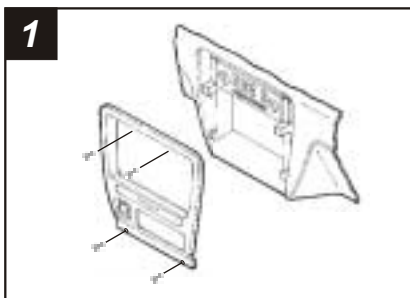

Disconnect the negative battery terminal to prevent an accidental short circuit. Remove (4) plastic screws from the base of the storage compartment. Pop out (4) anchor clips (securing the screws) and remove the compartment. Remove (2) Phillips screws from the base of the radio trim bezel. Remove (2) Phillips screws above the radio opening. Remove the ashtray. Pull up and out on the radio trim bezel and remove the bezel. Remove (4) Phillips screws securing the factory radio housing and remove the housing. Disconnect the wiring. Remove (2) Phillips screws securing the factory radio to the housing and remove the radio.

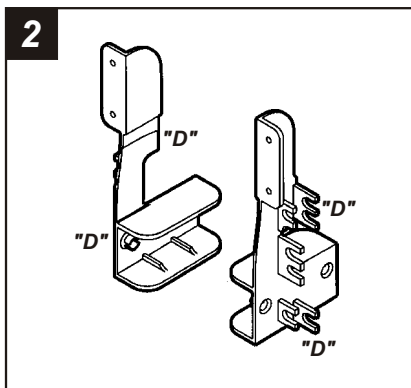

Cut and remove all mounting tabs on **Bracket Set #2** EXCEPT tabs "D". (The tabs can be identified by the stamped letter by each tab). Skip to the *Installation Instructions for ALL VEHICLES on Page #9*.

5

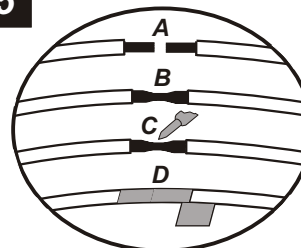

- A) Strip wire ends back ½"
- B) Twist ends together
- C) Solder
- D) Tape

Locate the factory wiring harness in the dash. Metra recommends using the proper mating adaptor and making connections as shown. (Isolate and individually tape off the ends of any unused wires to prevent electrical short circuit).

6

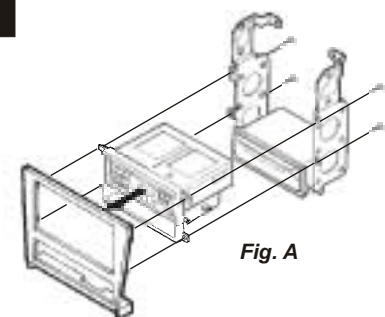

Re-connect the battery terminal and test the unit for proper operation.

MAXIMA 1995-99, I-30: Mount the head unit/kit assembly to the trim bezel and factory bracket assembly with factory screws and mount to the sub-dash with factory screws (Fig. A).

MAXIMA 2000-02: Mount the head unit/kit assembly to the factory bracket assembly with (4) **Phillips Flat-head Screws** supplied and mount to the sub-dash with factory screws.

240SX: Mount the head unit/kit assembly to the trim bezel (using tabs "B") with factory screws and then to the sub-dash (using tabs "C") with factory screws.

200SX, ALTIMA, FRONTIER, PATHFINDER, QUEST, SENTRA, VILLAGER, XTERRA: Mount the head unit/kit assembly to the sub-dash with factory screws.

INFINITI I-30 1996-99

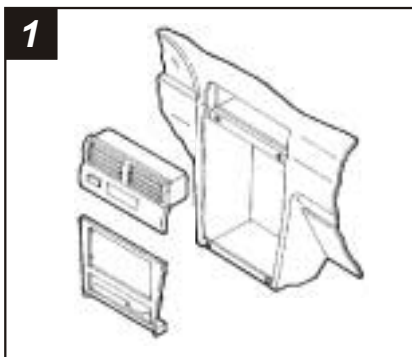

1 Disconnect the negative battery terminal to prevent an accidental short circuit. Unclip the gear shifter trim bezel and remove (2) screws exposed. Remove (1) screw to the left of the ashtray and unclip the ashtray assembly. Unclip the clock/vent assembly and remove. Remove (4) screws from the top of the mounting bracket assembly. Disconnect the wiring and remove the assembly. Remove the screws securing the mounting brackets to the assembly and remove the brackets.

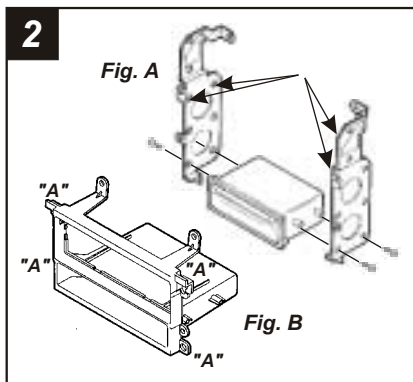

2 Using a hammer, flatten the protruding screw holes on the factory mounting brackets. Mount the factory pocket to the brackets with those screws previously removed in step #1 (Fig. A). Cut and remove all mounting tabs on the **Radio Housing** EXCEPT tabs "A" (Fig. B). The tabs can be identified by the stamped letter on each tab. Skip to the *Installation Instructions for ALL VEHICLES* on Page #9.

ALL VEHICLES

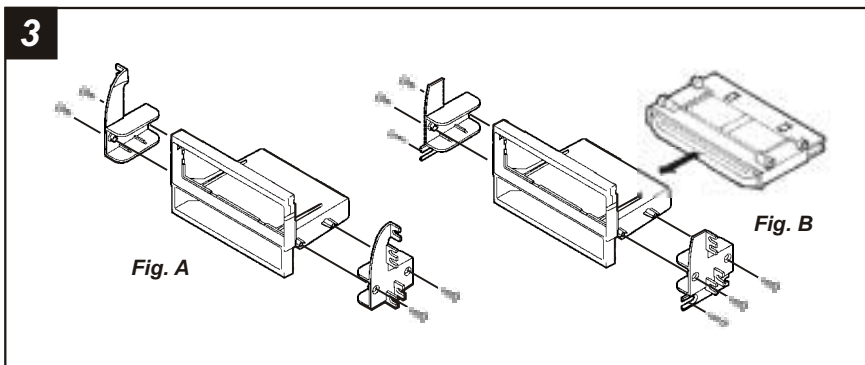

240SX, I-30, MAXIMA: Skip to step #4.

ALTIMA, FRONTIER, PATHFINDER, QUEST, VILLAGER, XTERRA: Cut and remove the mounting tabs from the **Radio Housing** and mount the converted Brackets to the Housing with (4) #8 x 1/2" Phillips Flat-head Screws supplied (Fig. A).

200SX, SENTRA: Cut and remove the mounting tabs from the **Radio Housing**. Mount one of the converted Brackets to the Housing with (2) #8 x 1/2" Phillips Flat-head Screws supplied and mount one side of the cupholder to the Bracket with (1) factory screw and (1) locating pin. Mount the other Bracket to the Housing with (2) #8 x 1/2" Phillips Flat-head Screws supplied and mount the other side of the cupholder with (1) factory screw and (1) locating pin (Fig. B).

MERCURY Villager / NISSAN Quest 1999-02

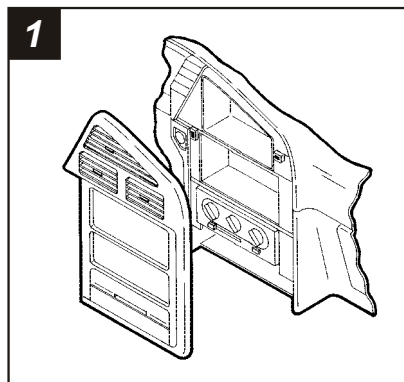

1 Disconnect the negative battery terminal to prevent an accidental short circuit. Open the ashtray/cupholder assembly, depress the retaining clips on each side and remove the assembly. Remove (2) Phillips screws from each side of the ashtray/cupholder assembly. Remove (4) plastic rivets from the lower pocket and slide the pocket back. (NOTE: It is NOT necessary to remove the pocket. Unclip the dash trim bezel and remove. Remove (4) Phillips screws securing the factory head unit and disconnect the wiring.

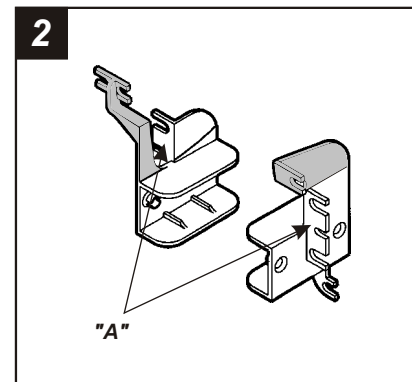

2 Cut **Bracket Set #1** along the scored lines removing the SHADED portions of the Brackets. Cut and remove all mounting tabs EXCEPT tabs "A". (The tabs can be identified by the stamped letter by each tab). Skip to the *Installation Instructions for ALL VEHICLES* on Page #9.

NISSAN 200SX 1995-98

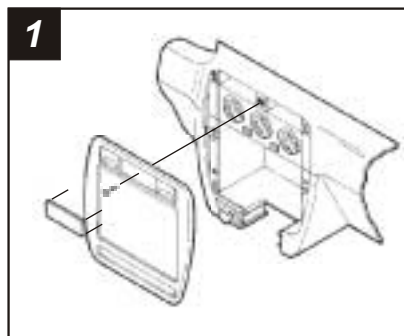

1 Disconnect the negative battery terminal to prevent an accidental short circuit. Unclip the dummy plate from the center of the switch panel (above the radio opening). Unclip the radio trim bezel and remove. Remove (4) Phillips screws securing the factory head unit and disconnect the wiring. Remove (2) Phillips screws securing the factory cupholder and remove.

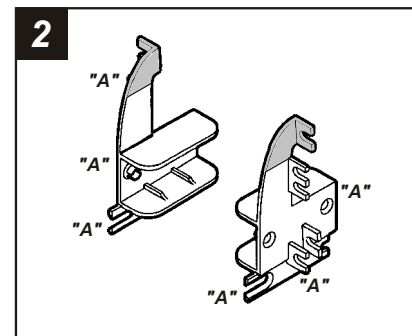

2 Cut **Bracket Set #3** along the scored lines removing the SHADED portions of the Brackets. Cut and remove all mounting tabs EXCEPT tabs "A". (The tabs can be identified by the stamped letter by each tab). Skip to the *Installation Instructions for ALL VEHICLES* on Page #9.

NISSAN 240SX 1995-98

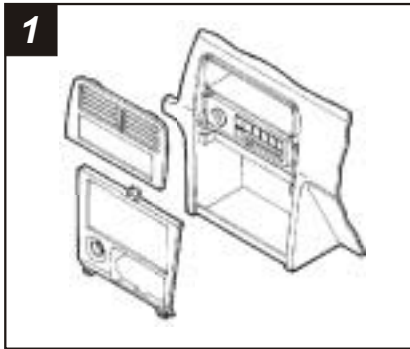

1
Disconnect the negative battery terminal to prevent an accidental short circuit. Unclip the climate control trim bezel and remove (2) screws exposed. Unclip the gear shifter trim bezel and remove (2) screws exposed. Remove the ashtray and (1) screw exposed. Unclip the radio trim bezel (the factory head unit, pocket and mounting brackets are secured to the bezel). Disconnect the wiring. Remove the screws securing the mounting brackets to the assembly and remove the brackets.

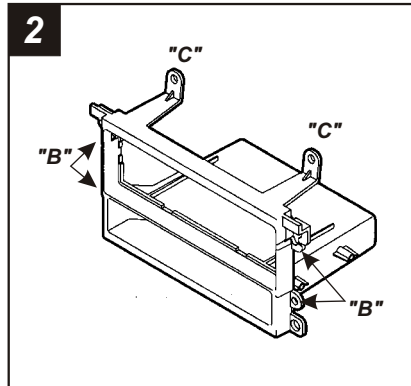

2
Cut and remove all mounting tabs on the **Radio Housing** EXCEPT tabs "**B**" and "**C**". (The tabs can be identified by the stamped letter on each tab). *Skip to the Installation Instructions for ALL VEHICLES on Page #9.*

NISSAN Sentra 1995-99

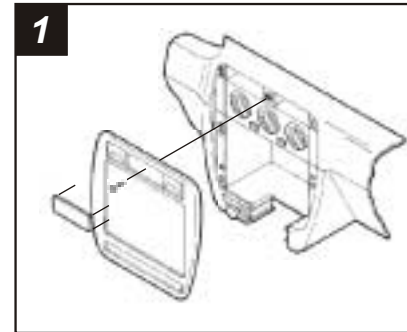

1
Disconnect the negative battery terminal to prevent an accidental short circuit. Unclip the dummy plate from the center of the switch panel (above the radio opening). Unclip the radio trim bezel and remove. Remove (4) Phillips screws securing the factory head unit and disconnect the wiring. Remove (2) Phillips screws securing the factory cupholder and remove.

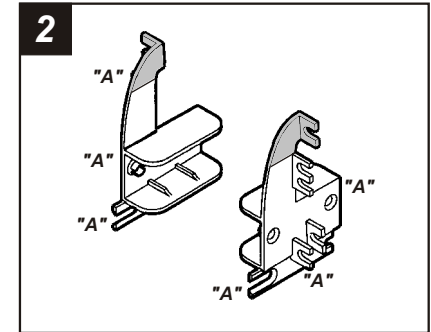

2
Cut **Bracket Set #3** along the scored lines removing the SHADED portions of the Brackets. Cut and remove all mounting tabs EXCEPT tabs "**A**". (The tabs can be identified by the stamped letter by each tab). *Skip to the Installation Instructions for ALL VEHICLES on Page #9.*

NISSAN Altima 1998-01

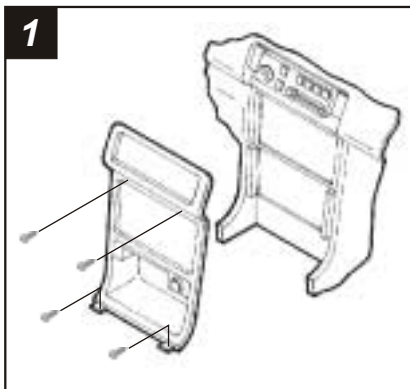

1
Disconnect the negative battery terminal to prevent an accidental short circuit. Unclip the gear shifter trim bezel and remove (2) Phillips screws exposed. Remove (2) Phillips screws above the radio opening. Unclip the radio trim bezel. Remove (4) Phillips screws from the factory head unit and disconnect the wiring.

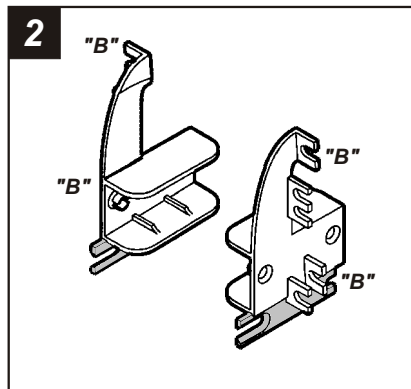

2
Cut **Bracket Set #3** along the scored lines removing the SHADED portions of the Brackets. Cut and remove all mounting tabs EXCEPT tabs "**B**". (The tabs can be identified by the stamped letter by each tab). *Skip to the Installation Instructions for ALL VEHICLES on Page #9.*

NISSAN Xterra 2000-01

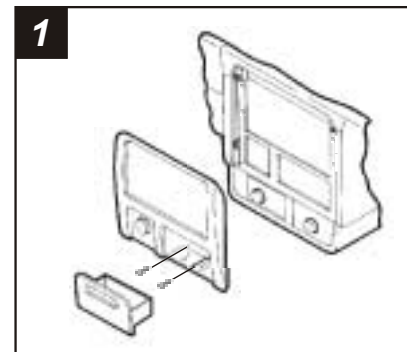

1
Disconnect the negative battery terminal to prevent an accidental short circuit. Remove the ashtray and (2) Phillips screws exposed in the ashtray cavity. Unclip the radio trim bezel and remove. Remove (4) Phillips screws securing the factory head unit and disconnect the wiring.

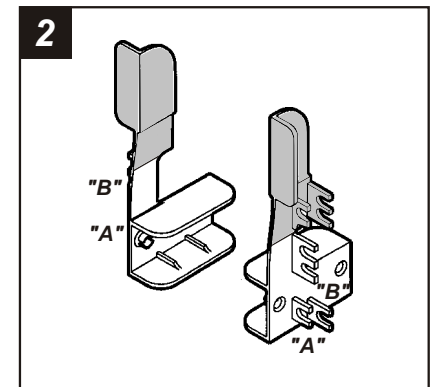

2
Cut **Bracket Set #2** along the scored lines removing the SHADED portions of the Brackets. Cut and remove all mounting tabs EXCEPT tabs "**A**" and "**B**". (The tabs can be identified by the stamped letter by each tab). *Skip to the Installation Instructions for ALL VEHICLES on Page #9.*

NISSAN Quest 1996-98

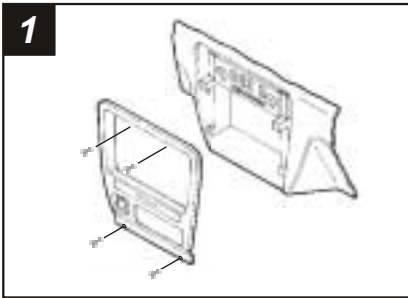

Disconnect the negative battery terminal to prevent an accidental short circuit. Remove (4) plastic screws from the base of the storage compartment. Pop out (4) anchor clips (securing the screws) and remove the compartment. Remove (2) Phillips screws from the base of the radio trim bezel. Remove (2) Phillips screws above the radio opening. Remove the ashtray. Pull up and out on the radio trim bezel and remove the bezel. Remove (4) Phillips screws securing the factory radio housing and remove the housing. Disconnect the wiring. Remove (2) Phillips screws securing the factory radio to the housing and remove the radio.

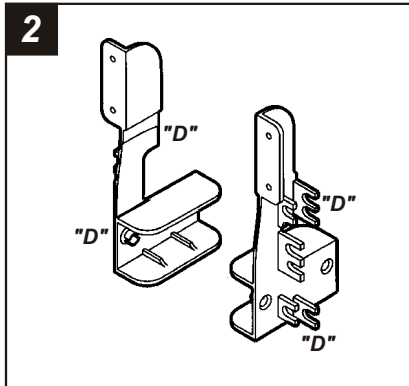

Cut and remove all mounting tabs on **Bracket Set #2** EXCEPT tabs "D". (The tabs can be identified by the stamped letter by each tab). Skip to the *Installation Instructions for ALL VEHICLES on Page #9*.

NISSAN Frontier 1998-01

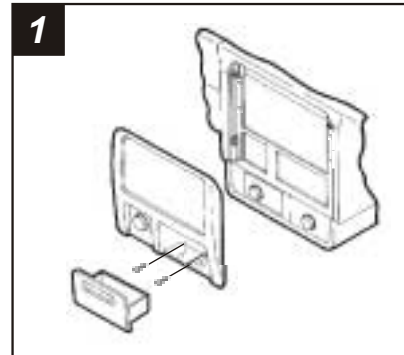

Disconnect the negative battery terminal to prevent an accidental short circuit. Remove the ashtray and (2) Phillips screws exposed in the ashtray cavity. Unclip the radio trim bezel and remove. Remove (4) Phillips screws securing the factory head unit and disconnect the wiring.

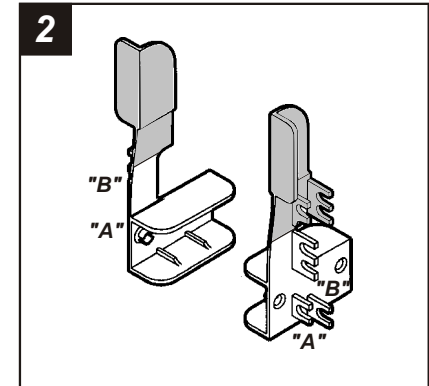

Cut **Bracket Set #2** along the scored lines removing the SHADED portions of the Brackets. Cut and remove all mounting tabs EXCEPT tabs "A" and "B". (The tabs can be identified by the stamped letter by each tab). Skip to the *Installation Instructions for ALL VEHICLES on Page #9*.

NISSAN Quest 1993-95

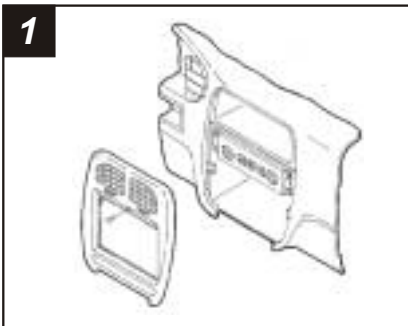

Disconnect the negative battery terminal to prevent an accidental short circuit. Remove (1) screw above the climate controls. Unclip the radio trim bezel and remove. Remove (4) Phillips screws securing the factory radio housing and remove the housing. Disconnect the wiring. Remove (8) Phillips screws securing the factory radio to the factory radio housing and remove the radio.

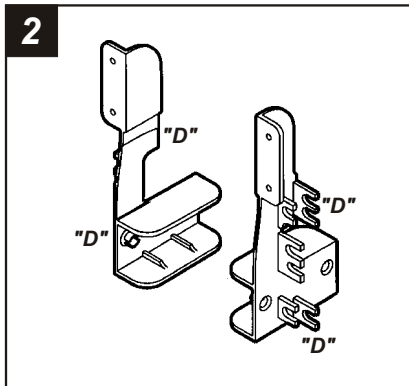

Cut and remove all mounting tabs on **Bracket Set #2** EXCEPT tabs "D". (The tabs can be identified by the stamped letter by each tab). Skip to the *Installation Instructions for ALL VEHICLES on Page #9*.

NISSAN Frontier / Xterra 2002

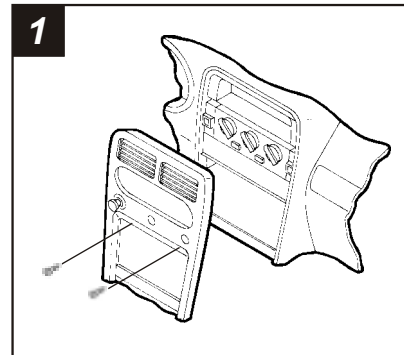

Disconnect the negative battery terminal to prevent an accidental short circuit. Unclip the gear shifter trim bezel and remove. Remove (2) Phillips screws exposed in the shifter cavity. Remove (2) Phillips screws under the climate control cluster. Unclip the radio trim bezel and remove. Remove (4) Phillips screws securing the factory head unit and disconnect the wiring. **CAUTION: DO NOT CYCLE THE KEY WHEN REMOVING A DASH WITH PASSENGER AIRBAG ON/OFF SWITCH).**

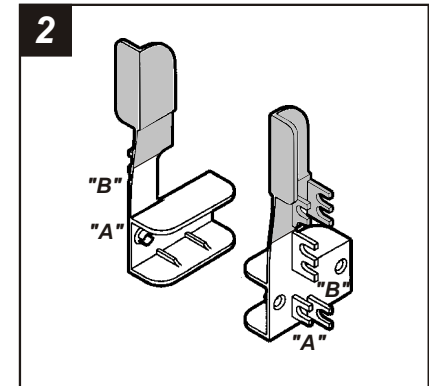

Cut **Bracket Set #2** along the scored lines removing the SHADED portions of the Brackets. Cut and remove all mounting tabs EXCEPT tabs "A" and "B". (The tabs can be identified by the stamped letter by each tab). Skip to the *Installation Instructions for ALL VEHICLES on Page #9*.

NISSAN Maxima 1995-99

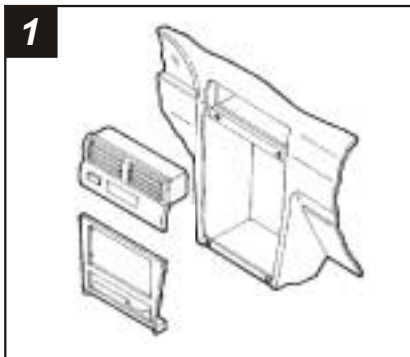

Disconnect the negative battery terminal to prevent an accidental short circuit. Unclip the gear shifter trim bezel and remove (2) screws exposed. Remove (1) screw to the left of the ashtray and unclip the ashtray assembly. Unclip the clock/vent assembly and remove. Remove (4) screws from the top of the mounting bracket assembly. Disconnect the wiring and remove the assembly. Remove the screws securing the mounting brackets to the assembly and remove the brackets.

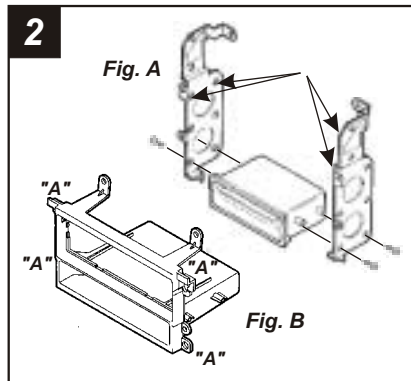

Using a hammer, flatten the protruding screw holes on the factory mounting brackets. Mount the factory pocket to the brackets with those screws previously removed in step #1 (Fig. A). Cut and remove all mounting tabs on the **Radio Housing** EXCEPT tabs "A" (Fig. B). The tabs can be identified by the stamped letter on each tab. Skip to the *Installation Instructions for ALL VEHICLES on Page #9*.

NISSAN Pathfinder 1996-00

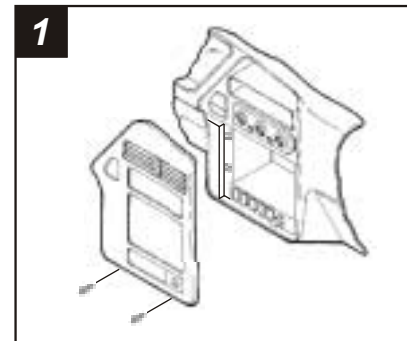

Disconnect the negative battery terminal to prevent an accidental short circuit. Remove (2) screws from the base of the radio trim bezel. Unclip the bottom edge of the radio trim bezel and disconnect the hazard light, defroster, wiper and cigarette lighter wiring. Remove the radio trim bezel. Remove (4) screws securing the factory head unit and disconnect the wiring.

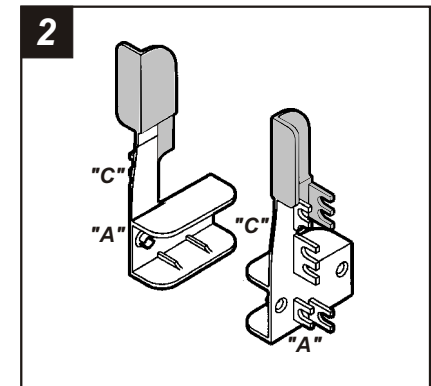

Cut **Bracket Set #2** along the scored lines removing the SHADED portions of the Brackets. Cut and remove all mounting tabs EXCEPT tabs "A" and "C". (The tabs can be identified by the stamped letter by each tab). Skip to the *Installation Instructions for ALL VEHICLES on Page #9*.

NISSAN Maxima 2000-02



Illustration not available

Disconnect the negative battery terminal to prevent an accidental short circuit. Unclip the vent/radio trim bezel assembly and remove. (NOTE: For Bose systems, the vent assembly will be removed without the bezel). Remove the ashtray insert and (1) Phillips screw exposed. Unclip the gear shifter bezel/ashtray assembly and remove. Remove (2) Phillips screws above the factory head unit and (2) Phillips screws below the climate control panel. Remove the head unit/climate control panel assembly and disconnect the wiring.

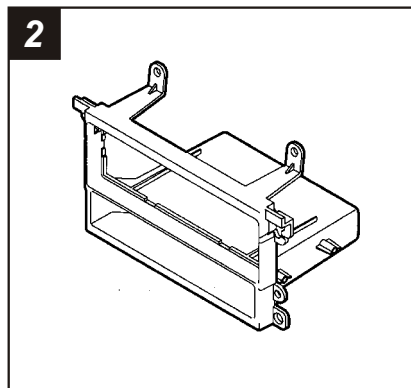

Cut and remove all mounting tabs on the **Radio Housing**. Skip to the *Installation Instructions for ALL VEHICLES on Page #9*.

NISSAN Pathfinder 2001-02



Illustration not available

Disconnect the negative battery terminal to prevent an accidental short circuit. Using a screwdriver, pry out on the top of the vent assembly (w/ clock) and remove. Remove (2) Phillips screws from the top of the radio trim bezel and remove. Remove (4) Phillips screws securing the factory head unit and disconnect the wiring.

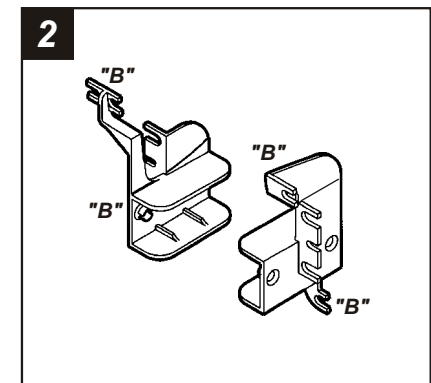

Cut and remove all mounting tabs from **Bracket Set #1** EXCEPT tabs "B". (The tabs can be identified by the stamped letter by each tab). Skip to the *Installation Instructions for ALL VEHICLES on Page #9*.