

KIT FEATURES

- ▶ Shaft and DIN unit provisions

KIT COMPONENTS

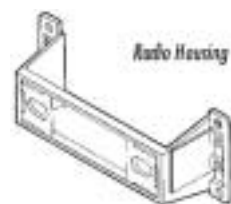

99-7615

INSTALLATION INSTRUCTIONS

APPLICATIONS

CAR	PAGE
NISSAN	
NX 1991-94.....	1-2
Sentra 1987-90.....	1-2
Sentra 1991-94.....	1-2



TOOLS REQUIRED



Phillips screwdriver



Cutting tool



Adjustable wrench

NISSAN Sentra 1987-90

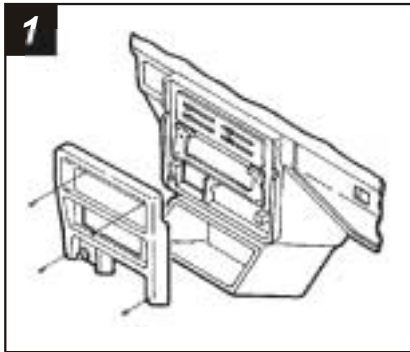

Disconnect the negative battery terminal to prevent an accidental short circuit. Remove the ashtray. Remove (2) screws above the climate controls. Remove (2) screws from the base of the radio trim bezel. Remove the bezel. Remove (4) screws securing the factory head unit and disconnect the wiring.

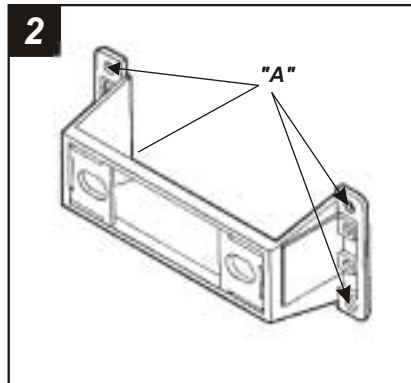

Locate mounting tabs "A" on the **Radio Housing**. The mounting tabs can be identified by the stamped letter on the back of each tab. Skip to the *Installation Instructions for ALL VEHICLES on Page #2*.

NISSAN Sentra 1991-94 NX 1991-94

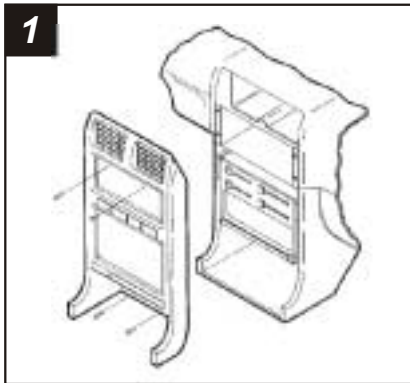

Disconnect the negative battery terminal to prevent an accidental short circuit. Remove the ashtray and (2) screws exposed. Remove (2) screws above the radio opening. Pry out on the a/c vents and remove (2) screws exposed (the left vent secures the vent control cable). Unclip the dash trim bezel and disconnect the cigarette lighter, illumination and switch connectors. Remove the bezel. Remove (4) screws securing the factory head unit and disconnect the wiring.

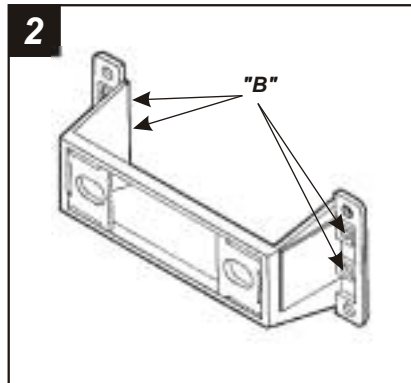

Cut and remove all mounting tabs on the **Radio Housing** EXCEPT tabs "B". The mounting tabs can be identified by the stamped letter on the back of each tab. Skip to the *Installation Instructions for ALL VEHICLES on Page #2*.

ALL VEHICLES

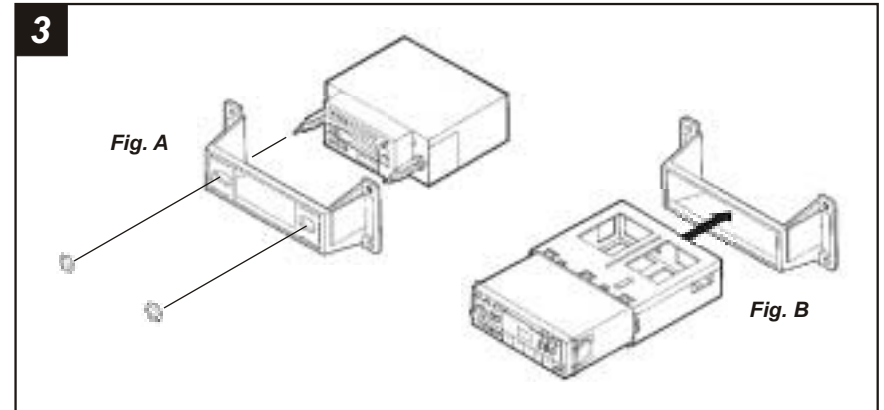

2-SHAFT HEAD UNITS: Slide the aftermarket head unit into the kit and secure with shaft nuts. (see Fig. A)

DIN HEAD UNITS: Cut and remove the shaft supports from the **Radio Housing**. Slide the DIN cage into the kit and secure by bending the metal locking tabs down. Slide the aftermarket head unit into the cage until secure. (see Fig. B)

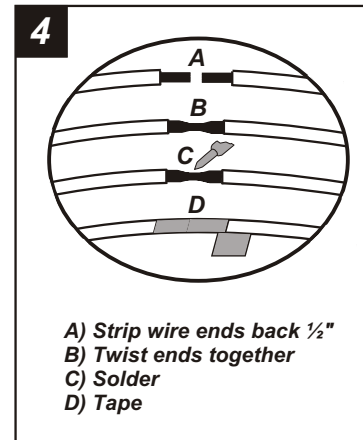

Locate the factory wiring harness in the dash. Metra recommends using the proper mating adaptor and making connections as shown. (Isolate and individually tape off the ends of any unused wires to prevent electrical short circuit).

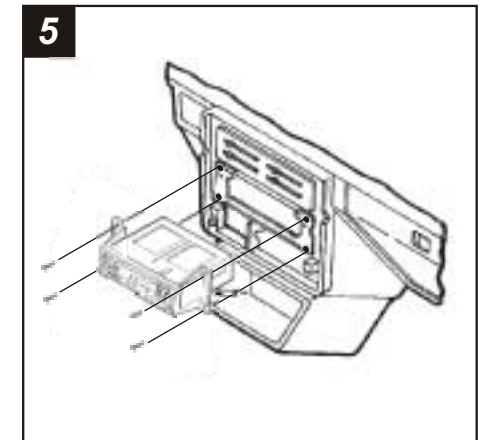

Re-connect the battery terminal and test the unit for proper operation. Mount the head unit/kit assembly to the sub-dash with (4) screws previously removed in step #1.