

KIT FEATURES

- ▶ Shaft and DIN unit provisions
- ▶ Rear support provisions

KIT COMPONENTS

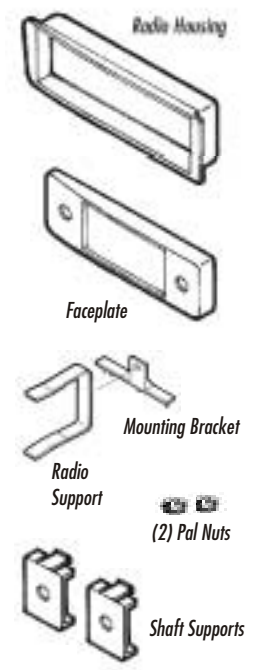

TOOLS REQUIRED



99-7891

INSTALLATION INSTRUCTIONS

APPLICATIONS

CAR	PAGE
HONDA	
Civic 1996-98.....	1-2



ALL VEHICLES

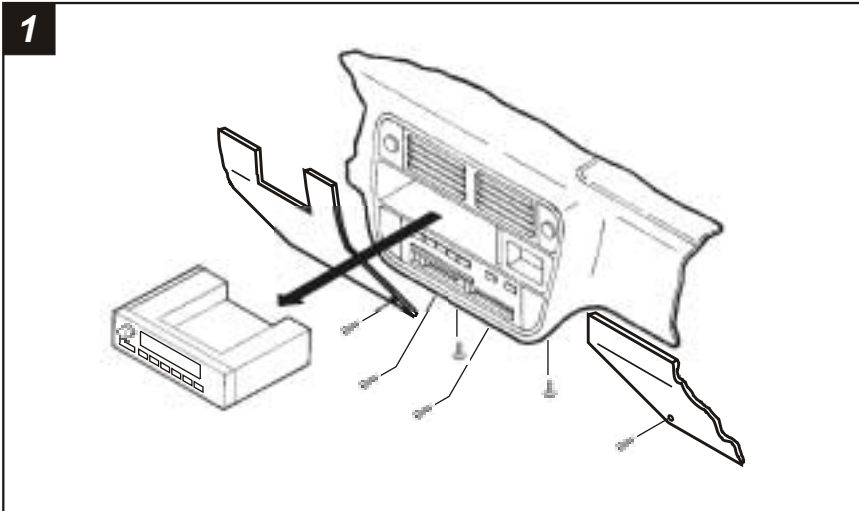

Disconnect the negative battery terminal to prevent an accidental short circuit. Remove (2) Phillips screws from the bottom edge of the glove box door and remove the door. Remove (3) Phillips screws from the lower steering column panel. Pull straight down on the lower steering column panel and remove the panel. Remove (2) Phillips screws under the climate control panel. Remove (4) Phillips screws from the lower dash location. Remove (2) 8mm hex-head screws securing the bottom-rear of the factory head unit and disconnect the wiring.

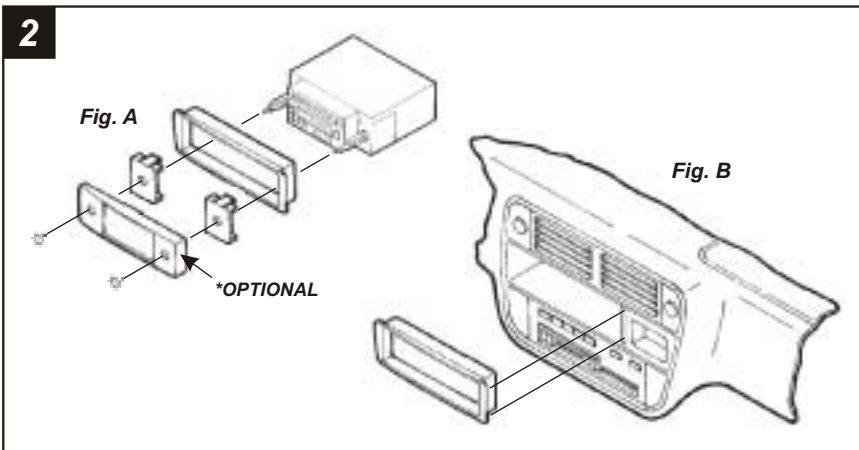

2-SHAFT HEAD UNITS: Snap the **Faceplate*** and **Shaft Supports** into the **Radio Housing**. Slide the aftermarket head unit into the kit and secure with shaft nuts. (see Fig. A)

DIN HEAD UNITS: Position the **Radio Housing** in the radio opening by inserting the locating pins on the right side of the Housing into the holes on the left side of the factory pocket. (see Fig. B)

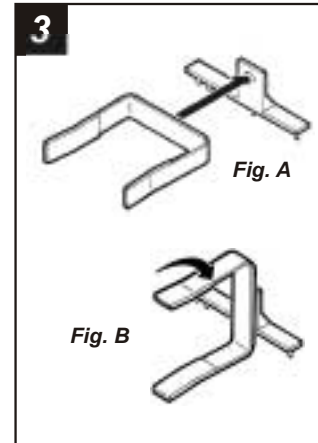

Insert the **Radio Support** into the **Mounting Bracket**. (see Fig. A). Turn the Radio Support to lock into place. (see Fig. B)

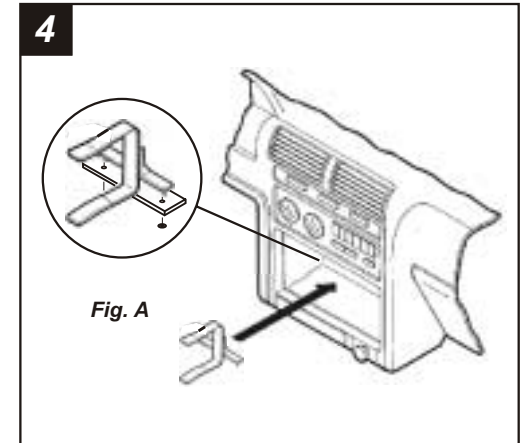

Mount the assembly to the factory mounting plate in the sub-dash with (2) **Pal Nuts** supplied. (see Fig. A)

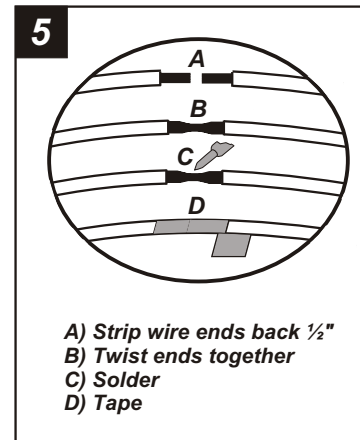

Locate the factory wiring harness in the dash. Metra recommends using the proper mating adaptor and making connections as shown. (Isolate and individually tape off the ends of any unused wires to prevent electrical short circuit).

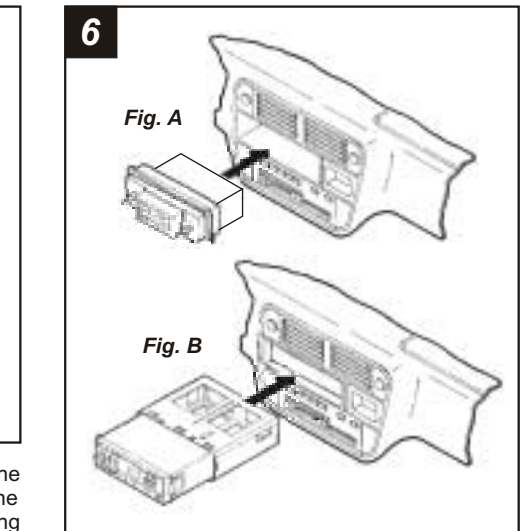

2-SHAFT HEAD UNITS: Re-connect the battery terminal and test the unit for proper operation. Snap the head unit/kit assembly into the sub-dash. Be sure the unit engages the **Radio Support** in the dash. (see Fig. A)

DIN HEAD UNITS: Re-connect the battery terminal and test the unit for proper operation. Slide the DIN cage into the mounted **Radio Housing** and secure by bending the metal locking tabs down. Slide the aftermarket head unit into the cage until secure. Be sure the unit engages the **Radio Support** in the dash. (see Fig. B)