

Mount the climate control pod to the back of the dash trim bezel with (3) Phillips screws previously removed in step #2.

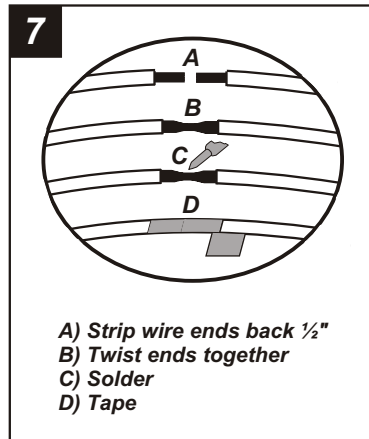

A) Strip wire ends back 1/2"  
 B) Twist ends together  
 C) Solder  
 D) Tape

Locate the factory wiring harness in the dash. Metra recommends using the proper mating adaptor and making connections as shown. (Isolate and individually tape off the ends of any unused wires to prevent electrical short circuit).

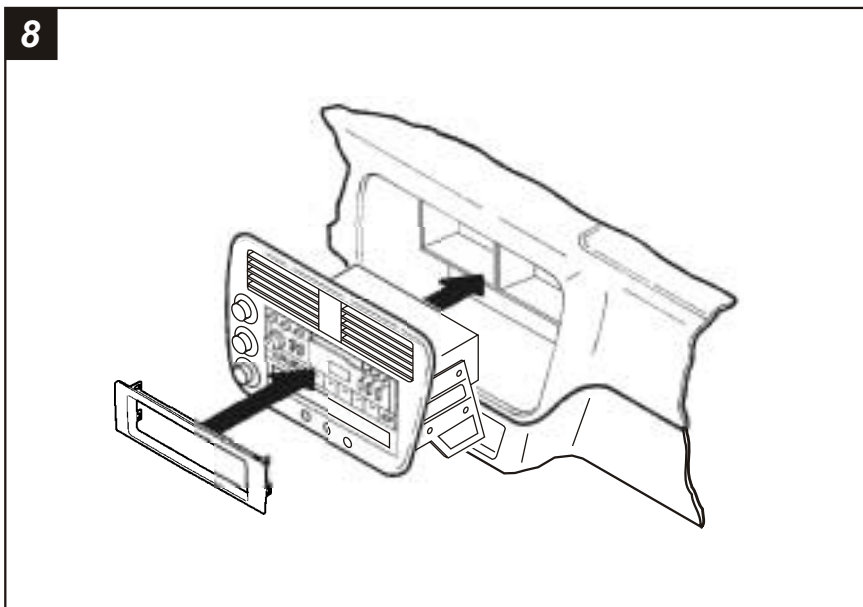

Re-connect the battery terminal and test the unit for proper operation. Slide the dash trim bezel assembly into the sub-dash and snap the **Faceplate** over the mounted head unit.

### KIT FEATURES

- ▶ ISO and DIN head unit provisions
- ▶ Factory pocket provisions

### KIT COMPONENTS

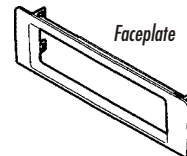
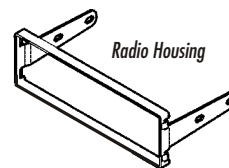

### TOOLS REQUIRED



Phillips screwdriver



Panel removal tool



Cutting tool



# 99-7897 INSTALLATION INSTRUCTIONS

### APPLICATIONS

| <b>CAR</b>       | <b>PAGE</b> |
|------------------|-------------|
| <b>HONDA</b>     |             |
| Civic 2003*..... | 1-3         |

\* This kit is not designed for Civic SI Model



## ALL VEHICLES

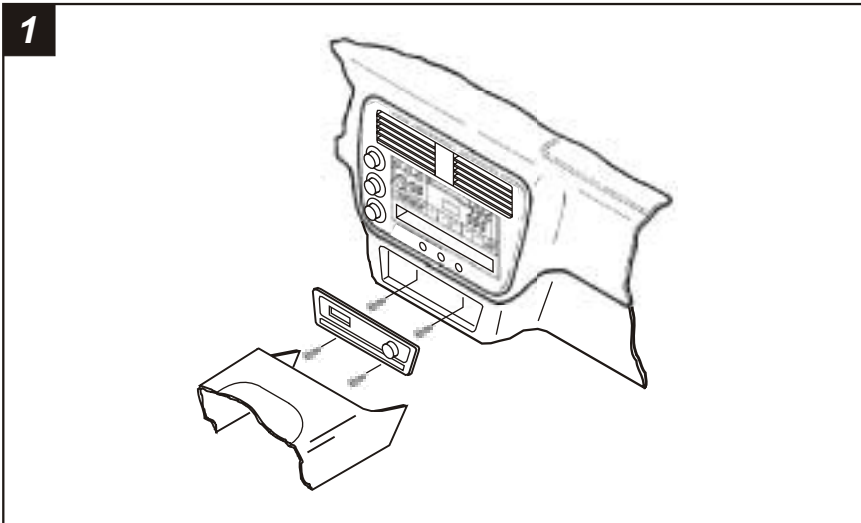

Disconnect the negative battery terminal to prevent an accidental short circuit. Unclip the parking brake trim panel and remove (2) Phillips screws exposed. Remove (1) plastic clip and (1) Phillips screw from each side of the center console. Slide the center console toward the back of the vehicle to access (2) Phillips screws on the power outlet panel. Unclip the power outlet panel and remove (2) Phillips screws exposed. Unclip the dash trim bezel assembly (including the head unit and climate controls) and remove the assembly.

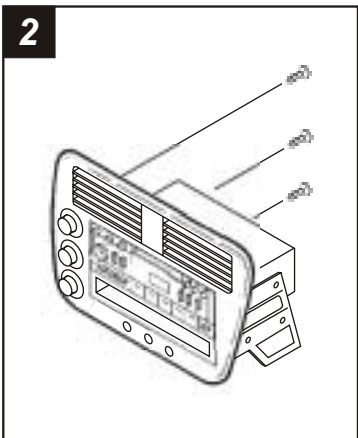

Remove (3) screws securing the climate control pod to the back of the dash trim bezel and remove the pod.

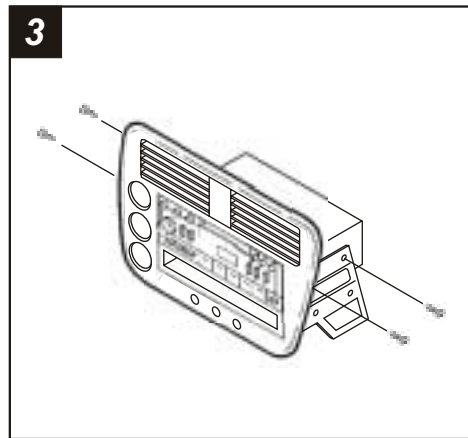

Remove (4) Phillips screws securing the factory head unit to the bracket assembly and remove the unit.

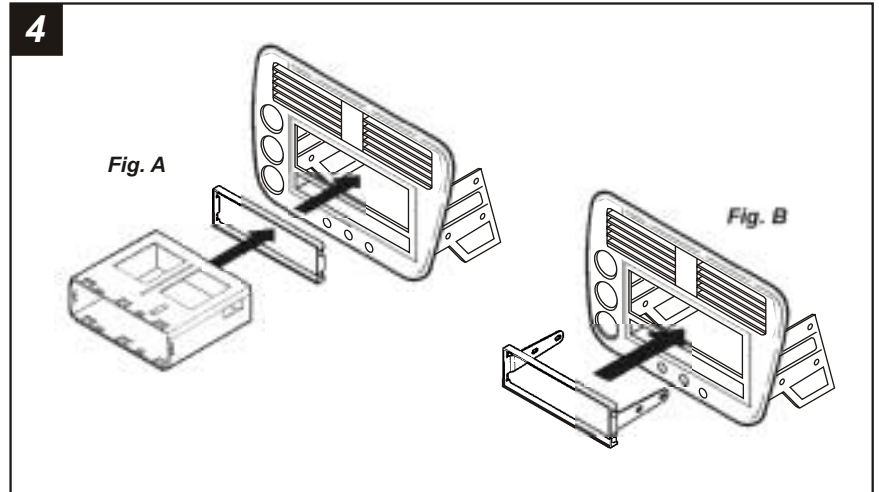

**DIN HEAD UNITS:** Cut and remove the ISO brackets from the **Radio Housing**. Snap the Radio Housing into the sub-dash, slide the DIN cage into the Housing and secure by bending the metal locking tabs down. (see Fig. A).

**ISO HEAD UNITS:** Snap the Radio Housing into the sub-dash. (see Fig. B).

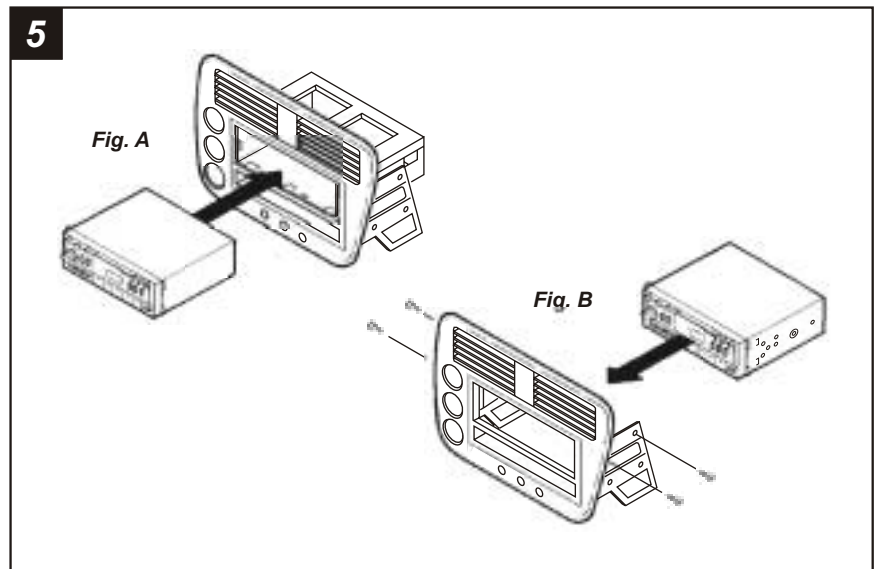

**DIN HEAD UNITS:** Slide the aftermarket head unit into the mounted cage until secure. (see Fig. A)

**ISO HEAD UNITS:** Slide the head unit into the mounted Radio Housing, align the holes in the head unit with the holes in the factory brackets and mount the unit to the brackets with the screws supplied with the unit. (see Fig. B).