

2-SHAFT HEAD UNITS: Snap the Faceplate onto the front of the Radio Housing. (For applications using **Faceplate #2**, cut and remove the bottom portion of the Faceplate). Slide the aftermarket head unit into the kit and secure with shaft nuts. (see Fig. A)

DIN HEAD UNITS: Cut and remove the shaft supports from the Faceplate and Radio Housing. (For applications using **Faceplate #2**, cut and remove the bottom portion of the Faceplate). Snap the Faceplate onto the front of the Housing. Slide the DIN cage into the kit and secure by bending the metal locking tabs down. Slide the aftermarket head unit into the cage until secure. (see Fig. B)

(If an equalizer will be included, slide the unit into the back of the **Radio Housing** and secure. If an equalizer will NOT be included, snap the **Equalizer Dummy Plate** into the opening).

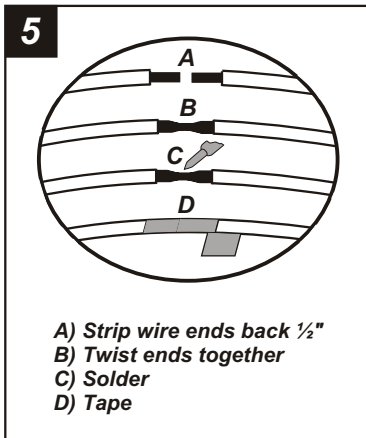

- A) Strip wire ends back 1/2"
- B) Twist ends together
- C) Solder
- D) Tape

Locate the factory wiring harness in the dash. Metra recommends using the proper mating adaptor and making connections as shown. (Isolate and individually tape off the ends of any unused wires to prevent electrical short circuit).

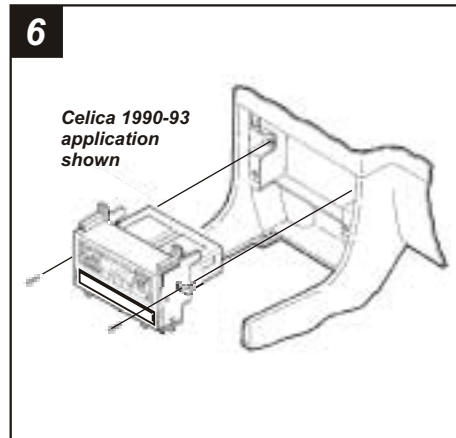

Re-connect the battery terminal and test the unit for proper operation. Mount the head unit/kit assembly to the sub-dash with those screws previously removed in step #1. (It may be necessary to trim the ends of the Mounting Tabs to provide proper clearance).

KIT COMPONENTS

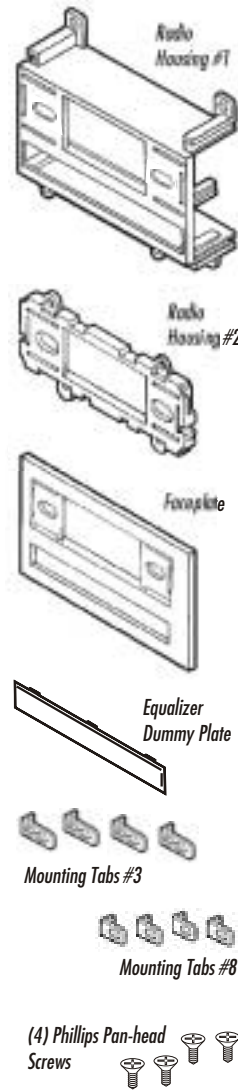

TOOLS REQUIRED



99-8100 INSTALLATION INSTRUCTIONS

APPLICATIONS

CAR	PAGE
TOYOTA	
4Runner 1984-88.....	8
Camry 1983-86.....	1
Celica 1982-85.....	1
Celica (GT/GTS) 1986-89.....	2
Celica (ST) 1986-89.....	2
Celica 1990-93.....	3
Corolla (sport coupe/liftback) 1982-83.....	3
Corolla 1984-87.....	4
Corolla (sedan/wagon-lower dash) 1988-93.....	4
Corolla (sedan/wagon-upper dash) 1988-93.....	5
Cressida 1985-87.....	5
Landcruiser 1982-87.....	6
Landcruiser 1988-92.....	6
MR2 1985-86.....	7
MR2 1987-90.....	7
Pickup 1984-88.....	8
Pickup (single DIN) 1989-91.....	8
Pickup (double DIN) 1989-91.....	9
Supra 1983-85.....	1
Supra 1986.5-92.....	9

TOYOTA Camry 1983-86

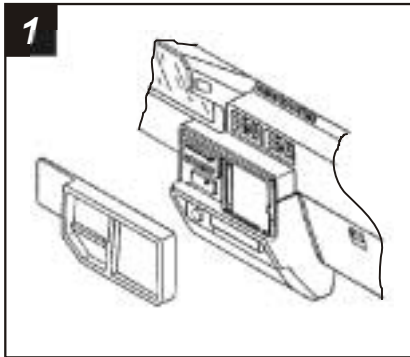

Disconnect the negative battery terminal to prevent an accidental short circuit. Remove (3) Phillips screws above the climate controls. Remove (2) Phillips screws from the left side of the dash trim bezel and remove the bezel. Remove the screws securing the factory head unit and disconnect the wiring.

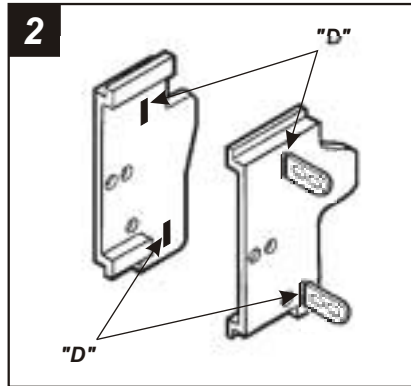

Slide **Mounting Tabs #3** into slots "**D**" on **Bracket Set #2**. The Mounting Tabs, Brackets and Bracket slots can be identified by the stamped letter on each component. Skip to the *Installation Instructions for ALL VEHICLES* on Page #10.

TOYOTA Celica / Supra 1983-85

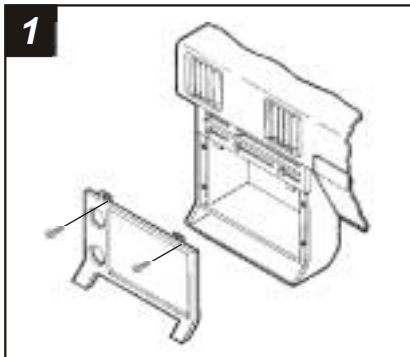

Disconnect the negative battery terminal to prevent an accidental short circuit. Remove the ashtray and the climate control knobs. Remove (3) flat-head screws from the climate control panel and remove the panel. Remove (2) Phillips screws from the top edge of the radio trim bezel. Remove (4) Phillips screws from the base of the radio trim bezel and remove the bezel. Remove (4) Phillips screws from the factory head unit and disconnect the wiring.

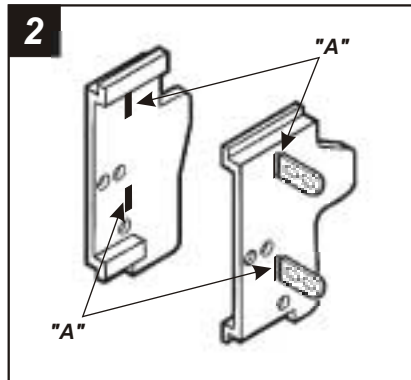

Slide **Mounting Tabs #3** into slots "**A**" on **Bracket Set #2**. The Mounting Tabs, Brackets and Bracket slots can be identified by the stamped letter on each component. Skip to the *Installation Instructions for ALL VEHICLES* on Page #10.

ALL VEHICLES

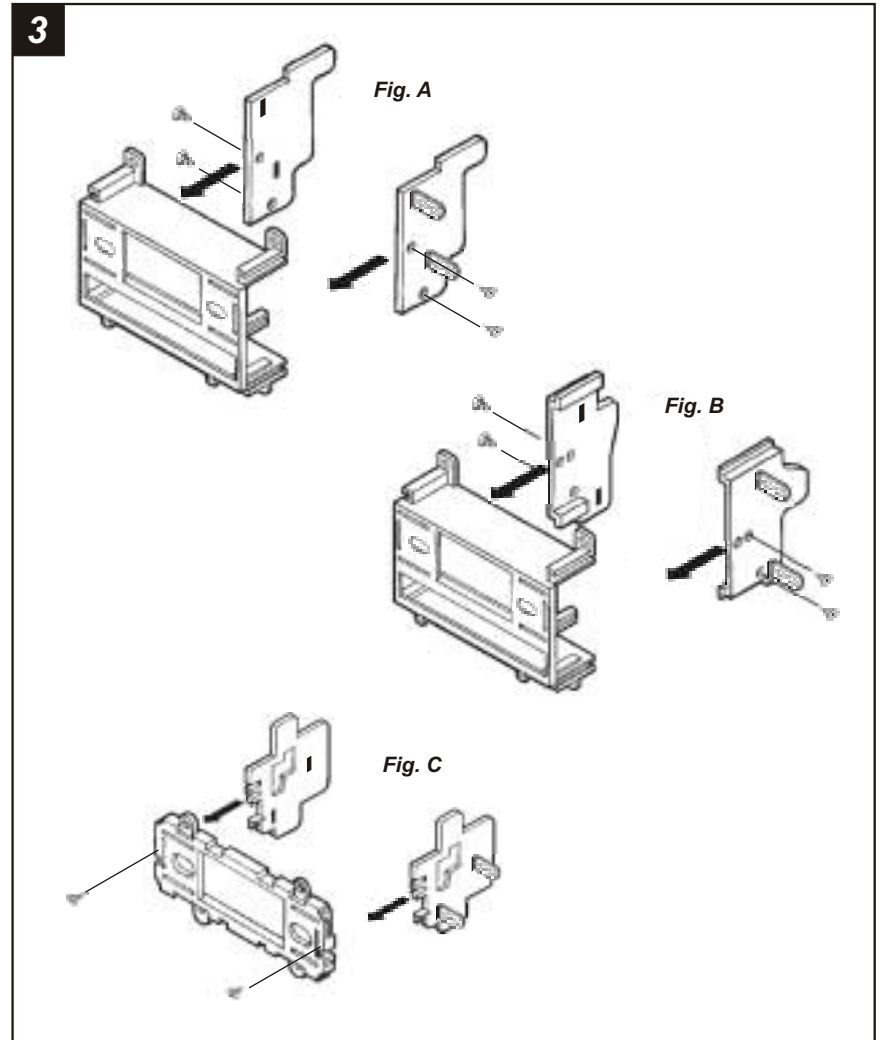

CELICA 1990-93, COROLLA (sport coupe/liftback) 1982-83, COROLLA (sedan/wagon-lower dash) 1988-92, COROLLA 1984-87, LANDCRUISER 1988-92, MR2 1987-90, PICKUP 1984-88, CRESSIDA, 4RUNNER: Mount **Bracket Set #1** to **Radio Housing #1** with (4) **Phillips Pan-head Screws** supplied. (see Fig. A)

CELICA 1982-85, CELICA 1986-89, COROLLA (lower dash) 1988-92, PICKUP (double DIN) 1989-91, SUPRA 1982-85, CAMRY: Mount **Bracket Set #2** to **Radio Housing #1** with (4) **Phillips Pan-head Screws** supplied. (see Fig. B)

COROLLA (upper dash) 1982-83, COROLLA (sedan/wagon-upper dash) 1988-92, LANDCRUISER 1982-87, MR2 1985-86, PICKUP (single DIN) 1989-91: Mount **Bracket Set #12** to **Radio Housing #2** with (2) **Phillips Pan-head Screws** supplied. (see Fig. C)

TOYOTA Pickup (double DIN) 1989-91

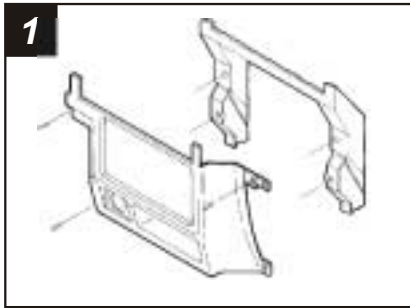

Disconnect the negative battery terminal to prevent an accidental short circuit. Remove (3) screws and (1) bolt securing the driver's side speaker panel and remove the panel. Remove (1) screw from the left side of the housing and unsnap the ignition cover. Remove the glove compartment assembly by removing (1) 10mm bolt from the bottom of the speaker panel and (3) screws from the right side of the housing. Remove the remaining (3) screws securing the radio trim bezel. Remove the screws securing the factory head unit and disconnect the wiring.

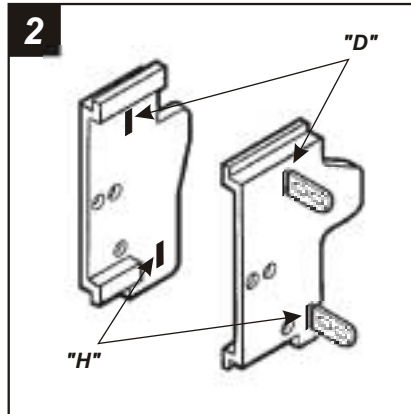

Slide **Mounting Tabs #3** into slots **"H"** and **"D"** on **Bracket Set #2**. The Mounting Tabs, Brackets and Bracket slots can be identified by the stamped letter on each component. Skip to the *Installation Instructions for ALL VEHICLES* on Page #10.

TOYOTA Celica (GT/GTS) 1986-89

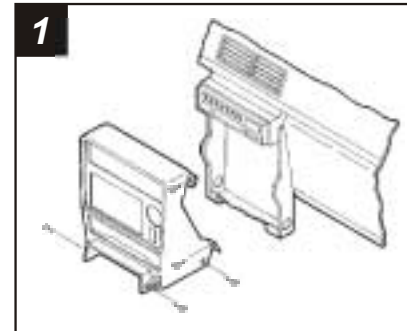

Disconnect the negative battery terminal to prevent an accidental short circuit. Remove (2) screws from the lower steering column panel and remove the panel. Remove (2) screws exposed on the dash trim bezel. Open the glove box and remove (2) screws exposed. Remove (2) screws from the ashtray cavity and (2) screws from the bracket. Remove (2) screws from each side of the dash trim bezel and unclip the bezel. Remove the screws securing the factory head unit and disconnect the wiring.

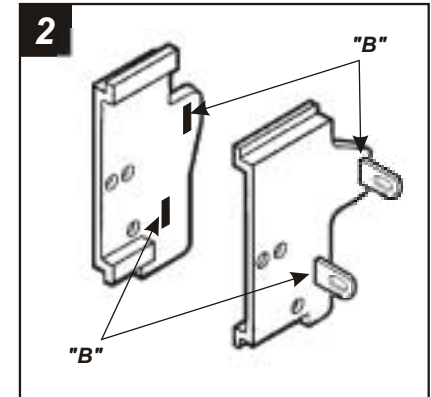

Slide **Mounting Tabs #3** and **#8** into slots **"B"** on **Bracket Set #2**. The Mounting Tabs, Brackets and Bracket slots can be identified by the stamped letter on each component. Skip to the *Installation Instructions for ALL VEHICLES* on Page #10.

TOYOTA Supra 1986-92

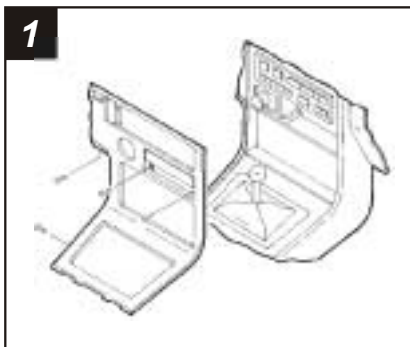

Disconnect the negative battery terminal to prevent an accidental short circuit. Remove the ashtray and (2) screws from the ashtray cavity. Remove (1) screw to the right of the steering column and (1) screw to the left of the gear shifter. Remove the screws securing the factory head unit and disconnect the wiring.

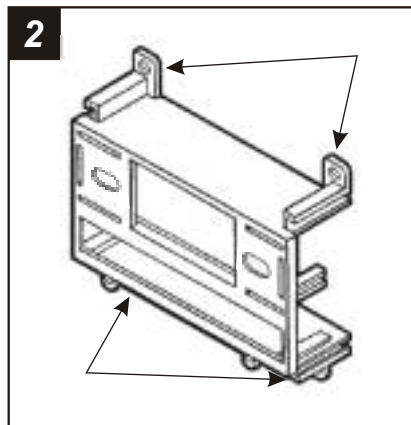

Locate the Mounting tabs on **Radio Housing #1**. (Brackets are NOT required for this vehicle). Skip to the *Installation Instructions for ALL VEHICLES* on Page #10.

TOYOTA Celica (ST) 1986-89

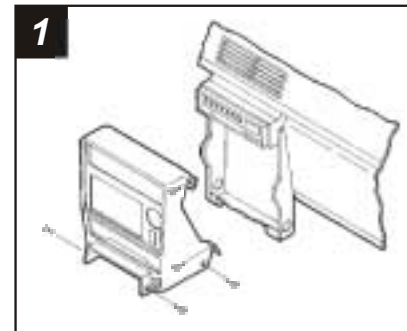

Disconnect the negative battery terminal to prevent an accidental short circuit. Remove (2) screws from the lower steering column panel and remove the panel. Remove (2) screws exposed on the dash trim bezel. Open the glove box and remove (2) screws exposed. Remove (2) screws from the ashtray cavity and (2) screws from the bracket. Remove (2) screws from each side of the dash trim bezel and unclip the bezel. Remove the screws securing the factory head unit and disconnect the wiring.

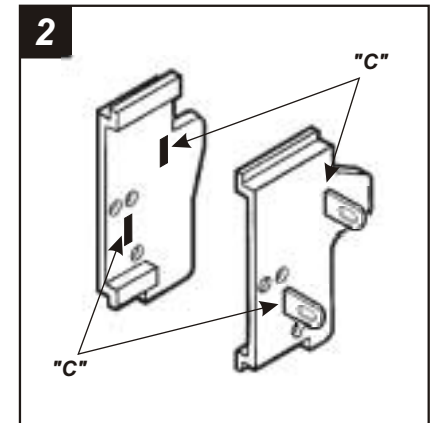

Slide **Mounting Tabs #8** into slots **"C"** on **Bracket Set #2**. The Mounting Tabs, Brackets and Bracket slots can be identified by the stamped letter on each component. Skip to the *Installation Instructions for ALL VEHICLES* on Page #10.

TOYOTA Celica 1990-93

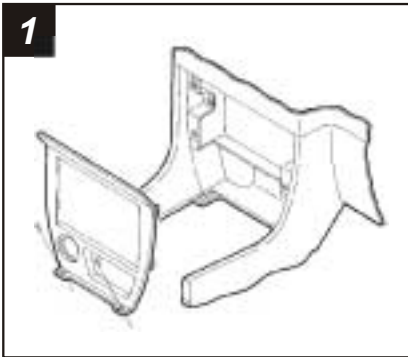

1
Disconnect the negative battery terminal to prevent an accidental short circuit. Pry up on the gear shifter trim panel and remove the panel. Remove (2) screws exposed on the bottom edge of the radio trim bezel. Unclip the bezel, and disconnect the ashtray and cigarette lighter wiring. Remove the screws securing the factory head unit and disconnect the wiring.

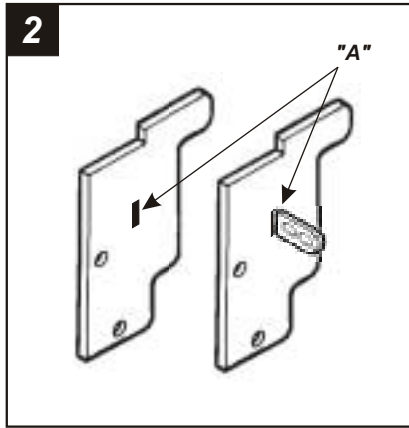

2
Slide **Mounting Tabs #3** into slots "**A**" on **Bracket Set #1**. The Mounting Tabs, Brackets and Bracket slots can be identified by the stamped letter on each component. Skip to the *Installation Instructions for ALL VEHICLES* on Page #10.

TOYOTA Pickup 1984-88 / 4Runner 1984-88

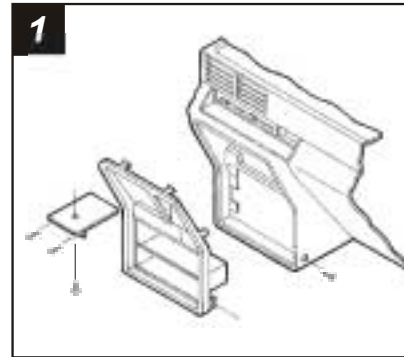

1
Disconnect the negative battery terminal to prevent an accidental short circuit. Remove the ashtray and (3) screws from the ashtray bracket. Remove (1) screw from each side of the dash console and unclip the dash trim bezel. Remove the screws securing the factory head unit and disconnect the wiring.

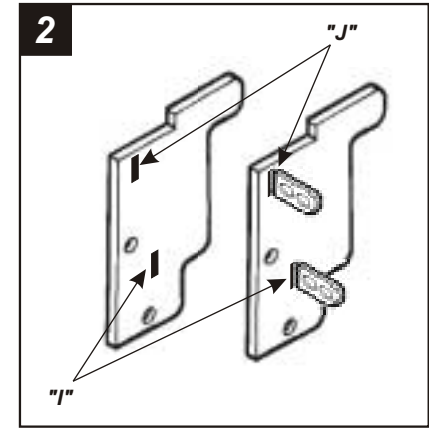

2
Slide **Mounting Tabs #3** into slots "**J**" and "**I**" on **Bracket Set #1**. The Mounting Tabs, Brackets and Bracket slots can be identified by the stamped letter on each component. Skip to the *Installation Instructions for ALL VEHICLES* on Page #10.

TOYOTA Corolla (sport coupe/liftback) 1982-83

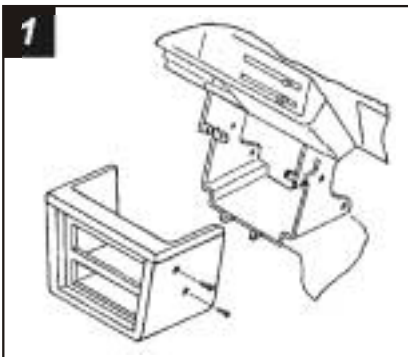

1
Disconnect the negative battery terminal to prevent an accidental short circuit. Remove (2) screws from each side of the dash trim bezel and remove the bezel. Remove (4) screws securing the upper radio dummy cover to the bezel and remove.

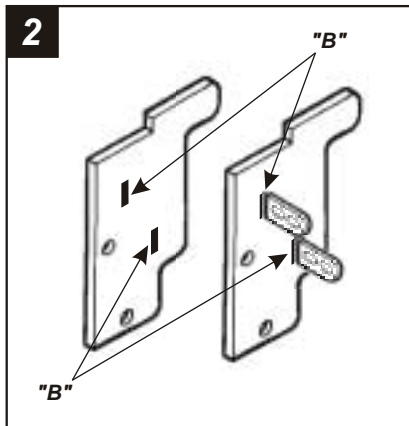

2
Slide **Mounting Tabs #3** into slots "**B**" on **Bracket Set #1**. The Mounting Tabs, Brackets and Bracket slots can be identified by the stamped letter on each component. Skip to the *Installation Instructions for ALL VEHICLES* on Page #10.

TOYOTA Pickup (single DIN) 1989-91

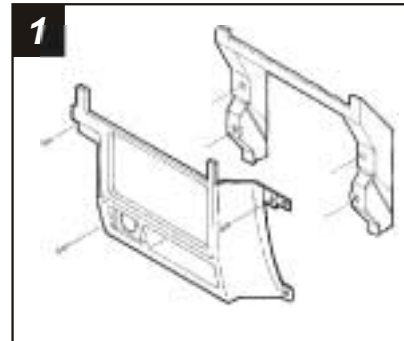

1
Disconnect the negative battery terminal to prevent an accidental short circuit. Remove (3) screws and (1) bolt securing the driver's side speaker panel and remove the panel. Remove (1) screw from the left side of the housing and unsnap the ignition cover. Remove the glove compartment assembly by removing (1) 10mm bolt from the bottom of the speaker panel and (3) screws from the right side of the housing. Remove the remaining (3) screws securing the radio trim bezel. Remove the screws securing the factory head unit and disconnect the wiring.

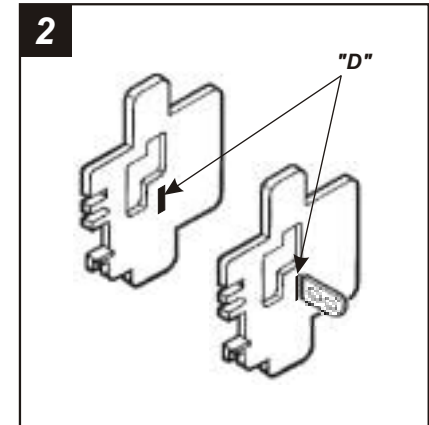

2
Slide **Mounting Tabs #3** into slots "**D**" on **Bracket Set #12**. The Mounting Tabs, Brackets and Bracket slots can be identified by the stamped letter on each component. Skip to the *Installation Instructions for ALL VEHICLES* on Page #10.

TOYOTA MR2 1985-86

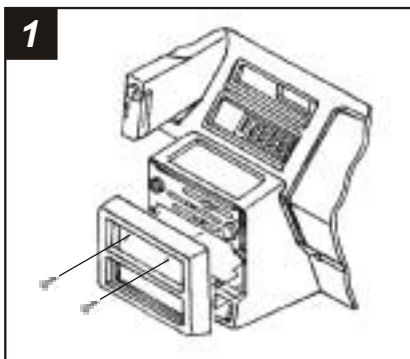

1
Disconnect the negative battery terminal to prevent an accidental short circuit. Remove (2) Phillips screws above the climate controls. Unclip the lower edge of the radio trim bezel and remove. Remove the screws securing the factory head unit and disconnect the wiring.

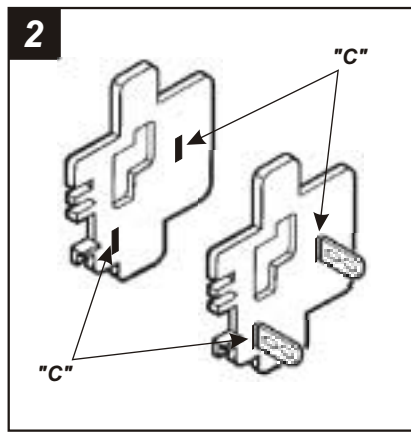

2
Slide **Mounting Tabs #3** into slots **"C"** on **Bracket Set #12**. The Mounting Tabs, Brackets and Bracket slots can be identified by the stamped letter on each component. Skip to the *Installation Instructions for ALL VEHICLES* on Page #10.

TOYOTA Corolla 1984-87

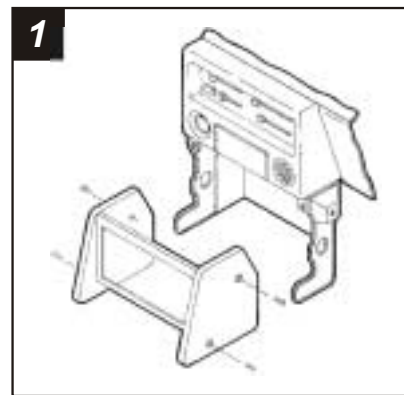

1
Disconnect the negative battery terminal to prevent an accidental short circuit. Remove (2) Phillips screws from each side of the radio trim bezel. Remove the bezel. Remove (4) screws securing the factory head unit and disconnect the wiring.

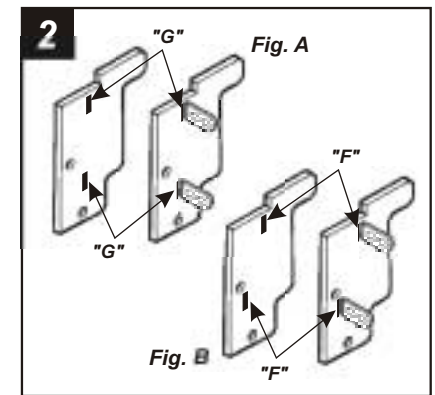

2
2DR/3DR MODELS: Slide **Mounting Tabs #3** into slots **"G"** on **Bracket Set #1**. (see Fig. A).
4DR/5DR MODELS: Slide **Mounting Tabs #3** into slots **"F"** on **Bracket Set #1**. (see Fig. B).
The Mounting Tabs, Brackets and Bracket slots can be identified by the stamped letter on each component. Skip to the *Installation Instructions for ALL VEHICLES* on Page #10.

TOYOTA MR2 1987-90



1
Disconnect the negative battery terminal to prevent an accidental short circuit. Remove (2) screws from the top of the dash trim bezel and remove the bezel. Remove (4) screws from the factory head unit (or coin tray dummy panel) and disconnect the wiring.

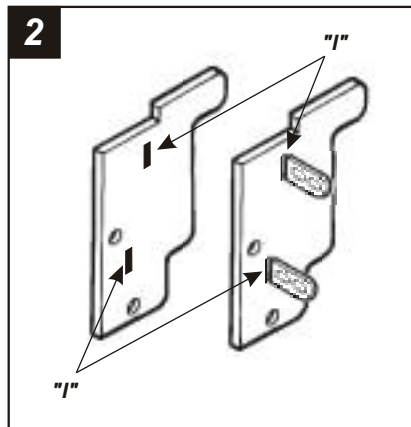

2
Slide **Mounting Tabs #3** into slots **"I"** on **Bracket Set #12**. The Mounting Tabs, Brackets and Bracket slots can be identified by the stamped letter on each component. Skip to the *Installation Instructions for ALL VEHICLES* on Page #10.

TOYOTA Corolla (sed/wag-lower dash) 1988-93

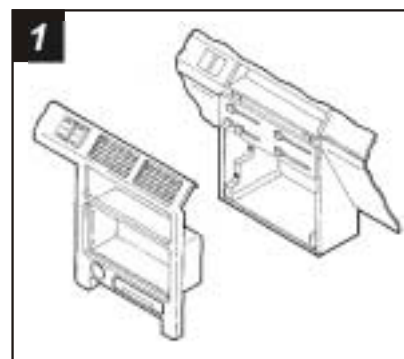

1
Disconnect the negative battery terminal to prevent an accidental short circuit. Remove (1) screw to the right of the ignition switch. Remove (1) screw above the left speaker. Unclip the dash trim bezel (some force may be required). Remove the screws securing the factory head unit and disconnect the wiring.

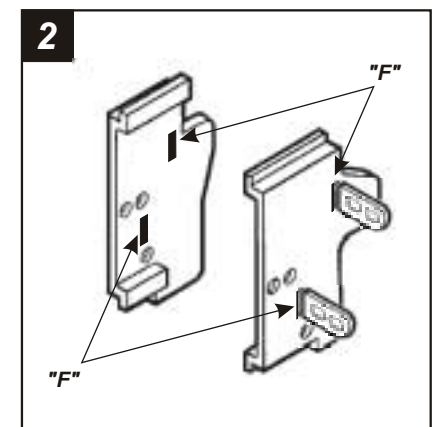

2
Slide **Mounting Tabs #3** into slots **"F"** on **Bracket Set #2**. The Mounting Tabs, Brackets and Bracket slots can be identified by the stamped letter on each component. Skip to the *Installation Instructions for ALL VEHICLES* on Page #10.

TOYOTA Corolla (sed/wag-upper dash) 1988-93

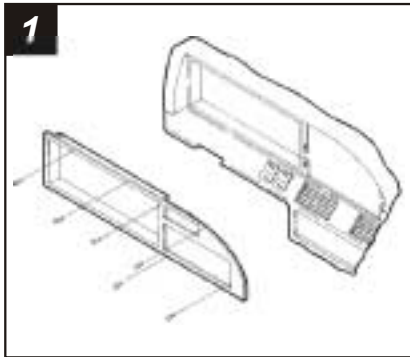

1
Disconnect the negative battery terminal to prevent an accidental short circuit. Remove (4) screws from the top edge of the dash trim bezel. Remove (2) screws below the radio opening. Remove (1) screw from the lower-left tab of the dash trim bezel (to the right of the a/c vent). Unclip the bezel. Remove the screws securing the factory head unit and disconnect the wiring.

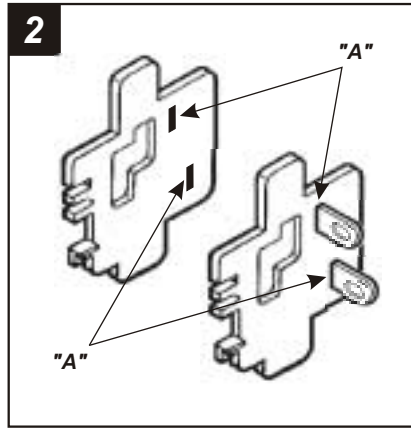

2
Slide **Mounting Tabs #8** into slots **"A"** on **Bracket Set #12**. The Mounting Tabs, Brackets and Bracket slots can be identified by the stamped letter on each component. Skip to the *Installation Instructions for ALL VEHICLES* on Page #10.

TOYOTA Landcruiser 1982-87

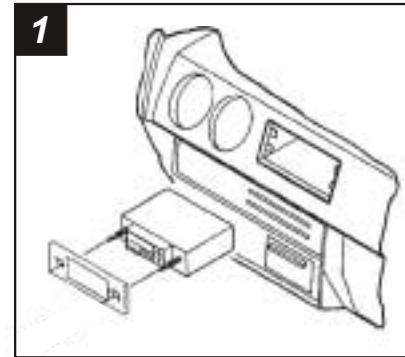

1
Disconnect the negative battery terminal to prevent an accidental short circuit. Remove (4) Phillips screws securing the factory head unit and disconnect the wiring.

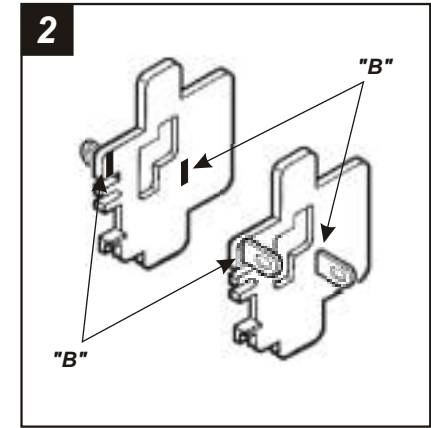

2
Slide **Mounting Tabs #3** and **#8** into slots **"B"** on **Bracket Set #12**. The Mounting Tabs, Brackets and Bracket slots can be identified by the stamped letter on each component. Skip to the *Installation Instructions for ALL VEHICLES* on Page #10.

TOYOTA Cressida 1985-87

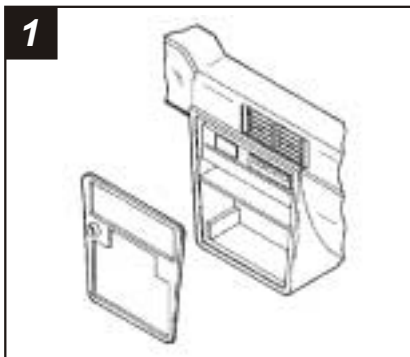

1
Disconnect the negative battery terminal to prevent an accidental short circuit. Unclip the climate control trim panel and remove (2) screws exposed. Remove (2) screws above the radio opening. Unclip the dash trim bezel, disconnect the wiring and remove the bezel. Remove (4) screws securing the factory head unit and disconnect the wiring.

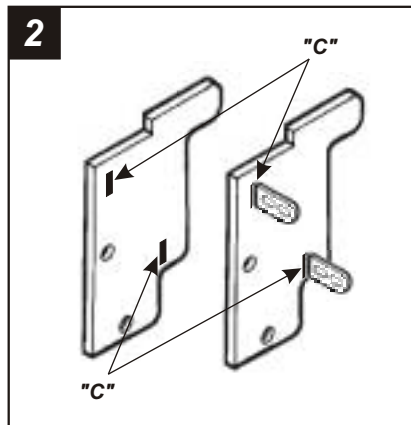

2
Slide **Mounting Tabs #3** into slots **"C"** on **Bracket Set #1**. The Mounting Tabs, Brackets and Bracket slots can be identified by the stamped letter on each component. Skip to the *Installation Instructions for ALL VEHICLES* on Page #10.

TOYOTA Landcruiser 1988-92

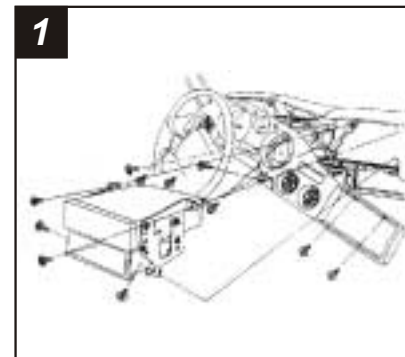

1
Disconnect the negative battery terminal to prevent an accidental short circuit. Remove (3) screws from the lower edge of the climate control panel. Remove (8) screws from the perimeter of the dash trim bezel. Pull out on the lower edge of the bezel and remove. Remove the screws securing the factory head unit and disconnect the wiring.

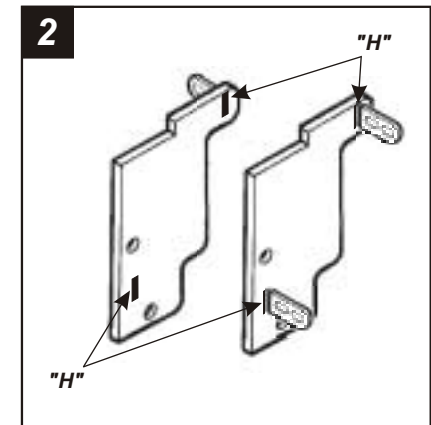

2
Slide **Mounting Tabs #3** into slots **"H"** on **Bracket Set #1**. The Mounting Tabs, Brackets and Bracket slots can be identified by the stamped letter on each component. Skip to the *Installation Instructions for ALL VEHICLES* on Page #10.