

Position the factory climate control module above the **Radio Housing** and secure to the **Mounting Brackets** with (4) Phillips screws previously removed in step #1.

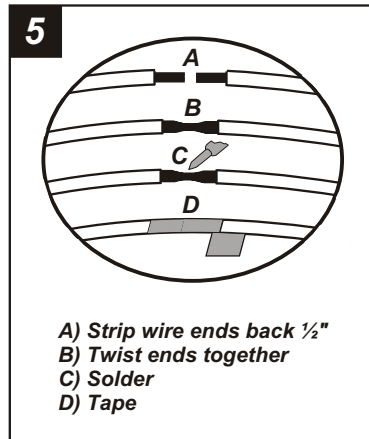

A) Strip wire ends back 1/2"
B) Twist ends together
C) Solder
D) Tape

Locate the factory wiring harness in the dash. Metra recommends using the proper mating adaptor and making connections as shown. (Isolate and individually tape off the ends of any unused wires to prevent electrical short circuit).

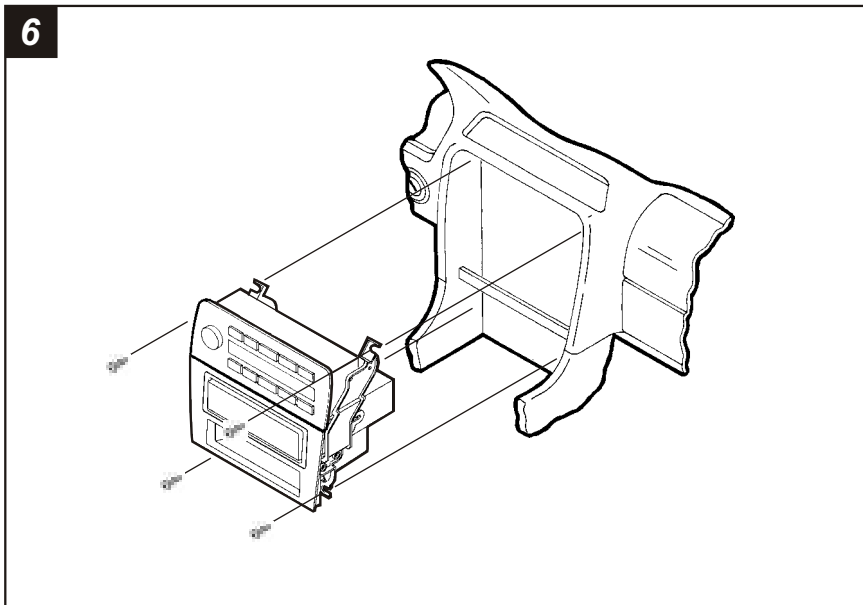

Re-connect the battery terminal and test the unit for proper operation. Mount the head unit/kit assembly to the sub-dash with (4) Phillips screws previously removed in step #1.

KIT FEATURES

- ▶ ISO and DIN head unit provisions
- ▶ Pocket

KIT COMPONENTS

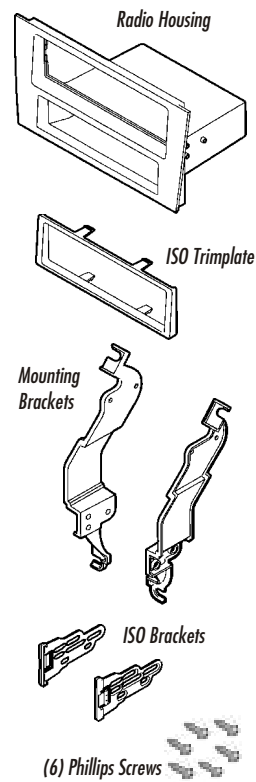

TOOLS REQUIRED

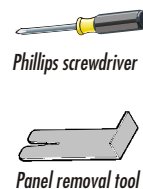

99-8150 INSTALLATION INSTRUCTIONS

APPLICATIONS

CAR	PAGE
LEXUS	
ES300 1992-96.....	1-3



ALL VEHICLES

1

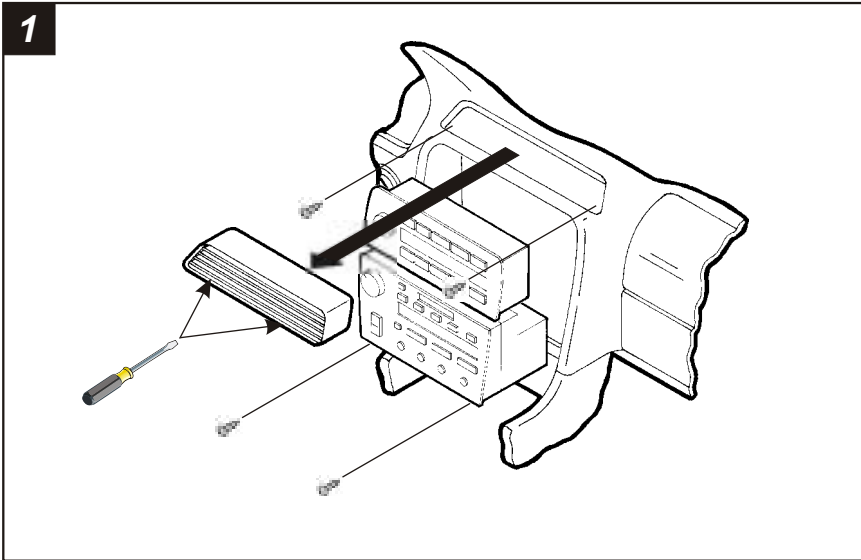

Disconnect the negative battery terminal to prevent an accidental short circuit. Unclip the plastic trim piece from the bottom of the factory head unit and remove (2) Phillips screws exposed. Insert a small flat-blade screwdriver into the air vents and disengage the clips securing the vents to the dash. Remove (2) Phillips screws exposed in the vent cavity. Pull the climate control module/head unit assembly from the sub-dash and disconnect the wiring. Remove (4) Phillips screws securing the climate control module to the factory brackets and remove the module.

2

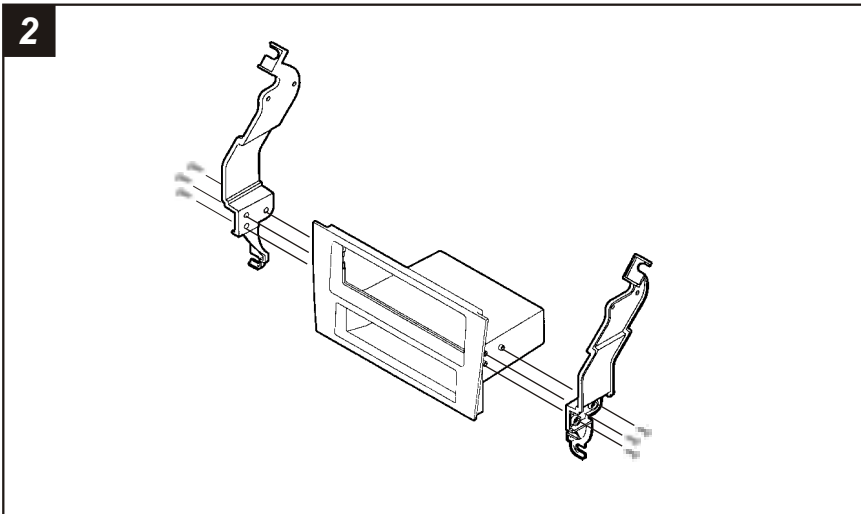

Mount the **Mounting Brackets** to the **Radio Housing** with (6) **Phillips Screws** supplied.

1

3

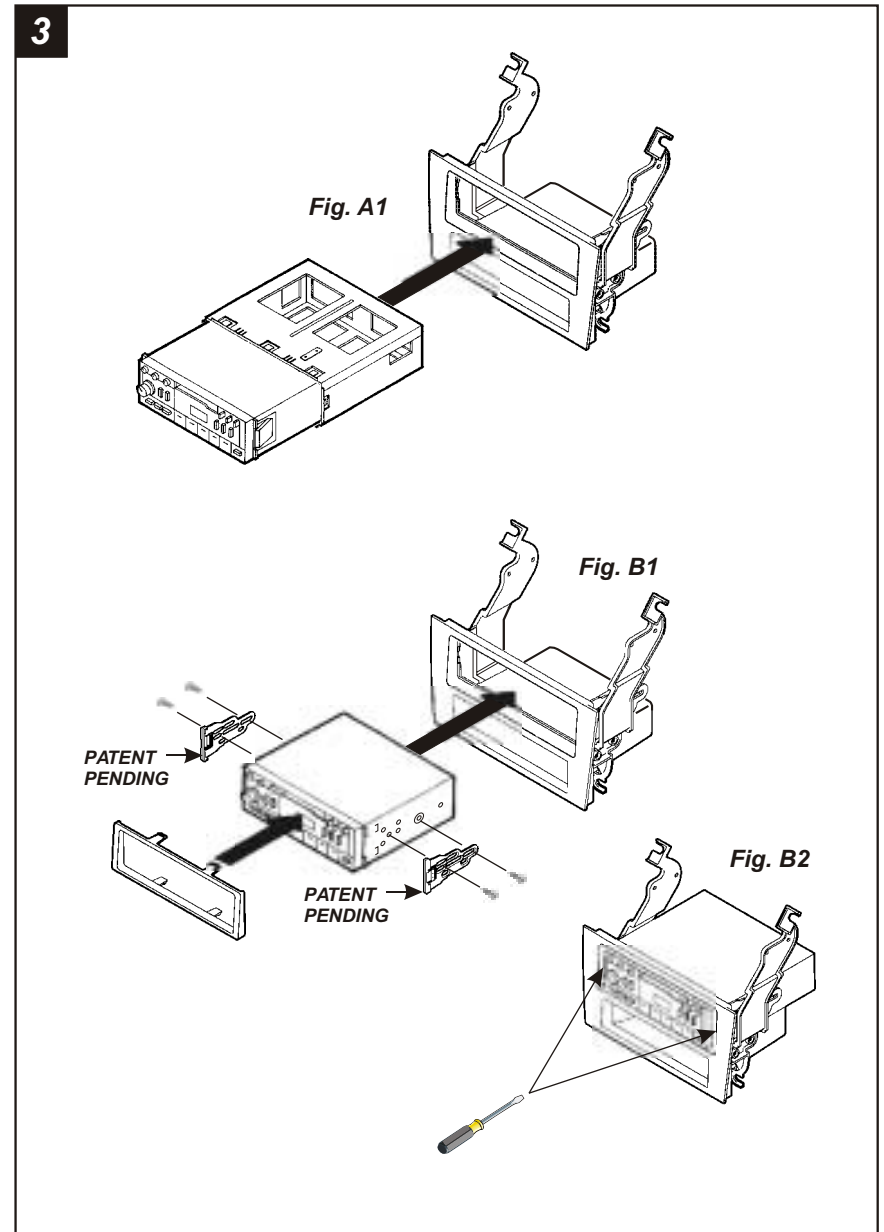

DIN HEAD UNITS: Slide the DIN cage into the **Radio Housing** and secure by bending the metal locking tabs down. Slide the aftermarket head unit into the cage and secure. (see Fig. A1)

ISO HEAD UNITS: Align the holes in the **ISO Brackets** with the holes in the head unit and mount the Brackets to the head unit with the screws supplied with the unit. Slide the head unit/bracket assembly into the radio opening until the side clips engage and snap the **ISO Trimplate** over the unit (see Fig. B1). **NOTE:** To remove the mounted head unit, unclip and remove the ISO Trimplate. Using a small flat-blad screwdriver, disengage the side clips securing the ISO Brackets to the Radio Housing (see Fig. B2).

2