

ALL VEHICLES

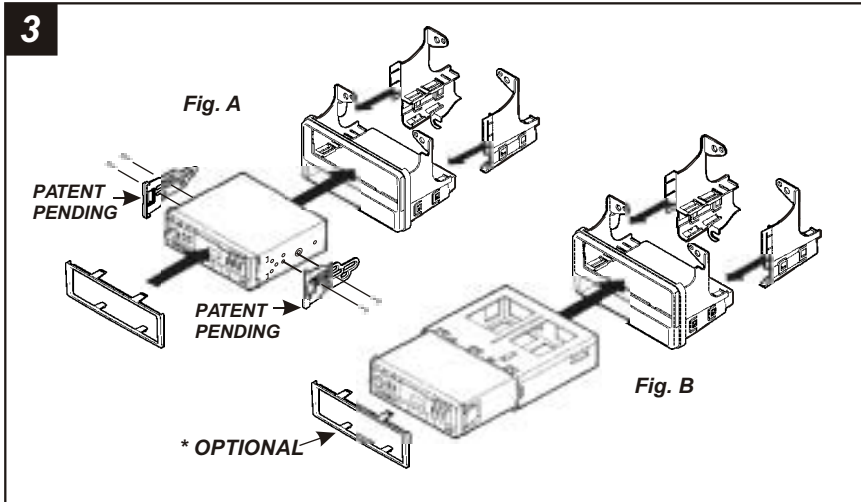

ISO HEAD UNITS: Slide the **Mounting Brackets** onto the sides of the **Radio Housing** until the side clips engage. Mount the **ISO Brackets** to the head unit with the screws supplied with the unit. Slide the head unit into the radio opening until the side clips engage. Snap the **Trimplate** into the Radio Housing. (see Fig. A).

DIN HEAD UNITS: Slide the **Mounting Brackets** onto the sides of the **Radio Housing** until the side clips engage. Slide the DIN cage into the Housing and secure by bending the metal locking tabs down. Slide the aftermarket head unit into the cage and secure. Snap the ***Trimplate** into the Radio Housing. (see Fig. B)

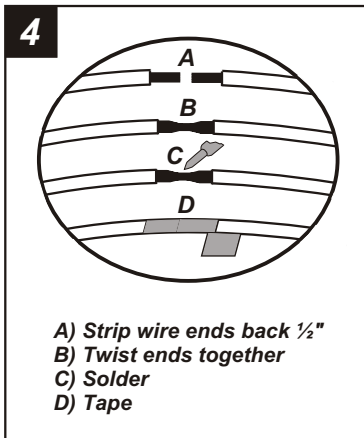

Locate the factory wiring harness in the dash. Metra recommends using the proper mating adaptor and making connections as shown. (Isolate and individually tape off the ends of any unused wires to prevent electrical short circuit).

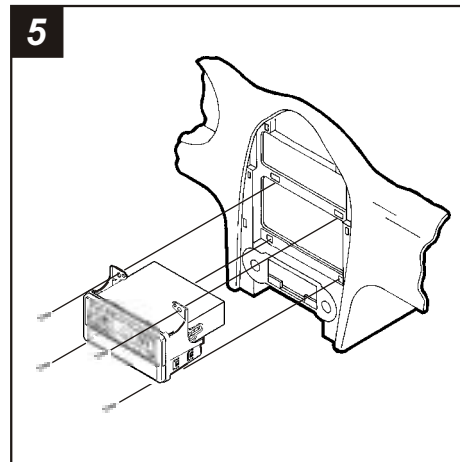

Re-connect the battery terminal and test the unit for proper operation. Mount the head unit/kit assembly to the sub-dash with (4) screws previously removed in step #1.

KIT FEATURES

- ▶ ISO and DIN head unit provisions
- ▶ Pocket provisions

KIT COMPONENTS

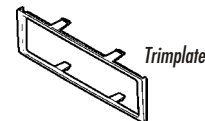
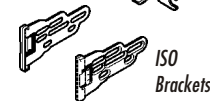
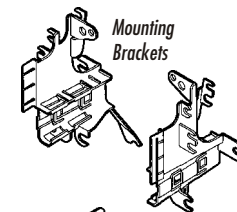
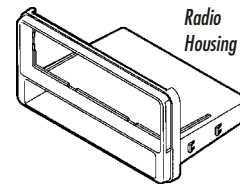

TOOLS REQUIRED



Phillips screwdriver



Cutting tool



Socket wrench



99-8202 INSTALLATION INSTRUCTIONS

APPLICATIONS

CAR	PAGE
TOYOTA	
Celica 2000-02.....	1
Echo 2000-02.....	1
MR2 Spyder 2000-02.....	2
RAV-4 2001-02.....	2



TOYOTA Celica 2000-02

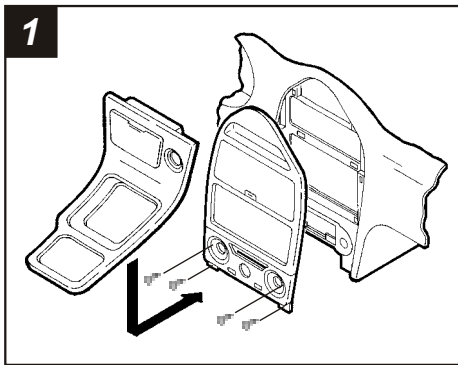

Disconnect the negative battery terminal to prevent an accidental short circuit. Unclip and remove the gear shifter trim bezel and remove (2) Phillips screws exposed below the climate controls. Pull off climate control knobs and remove (2) Phillips screws exposed. Unclip the climate control/factory radio trim bezel and remove. Remove (4) 10mm screws securing the factory head unit and disconnect the wiring.

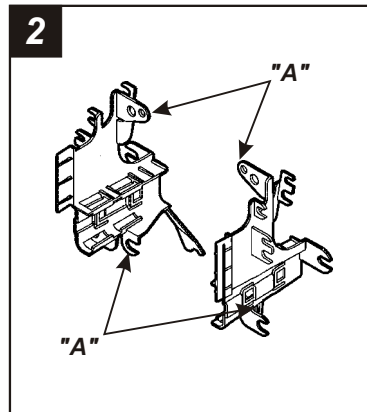

Cut and remove all tabs on the **Mounting Brackets** EXCEPT tabs "A". (The tabs can be identified by the stamped letter by each tab). Skip to the *Installation Instructions for ALL VEHICLES on Page #3*.

TOYOTA MR2 Spyder 2000-02

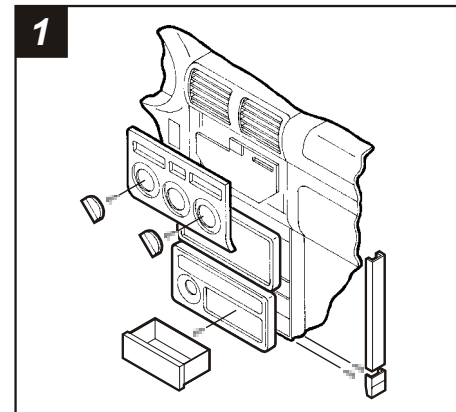

Disconnect the negative battery terminal to prevent an accidental short circuit. Unsnap the lower trim piece from each side of the dash console and remove (2) Phillips screws exposed in each cavity. Remove the upper trim piece from each side of the console. Remove the climate control knobs and (2) Phillips screws exposed. Remove the climate control trim bezel. Remove the ashtray and (1) 10mm bolt exposed. Unclip the ashtray trim bezel and remove. Unclip the radio trim bezel, remove (4) Phillips screws securing the unit and disconnect the wiring.

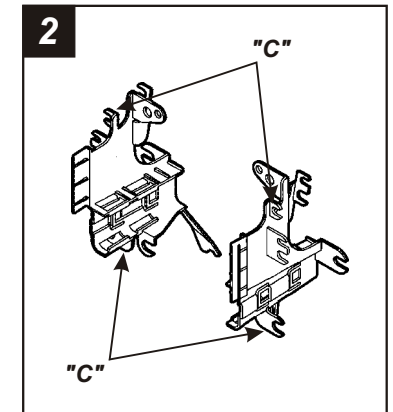

Cut and remove all tabs on the **Mounting Brackets** EXCEPT tabs "C". (The tabs can be identified by the stamped letter by each tab). Skip to the *Installation Instructions for ALL VEHICLES on Page #3*.

TOYOTA Echo 2000-02

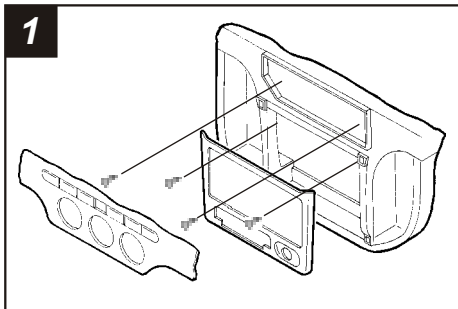

Disconnect the negative battery terminal to prevent an accidental short circuit. Remove the climate control knobs and (2) Phillips screws exposed. Unclip and remove the climate control trim bezel. Depress the side clips securing the climate control panel and move the panel to access (2) Phillips screws from the top of the factory radio brackets. Remove the ashtray. Unclip and remove the radio trim bezel. Remove (2) Phillips screws from the bottom of the radio brackets and disconnect the wiring.

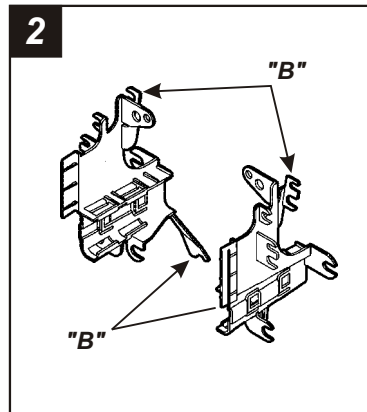

Cut and remove all tabs on the **Mounting Brackets** EXCEPT tabs "B". (The tabs can be identified by the stamped letter by each tab). Skip to the *Installation Instructions for ALL VEHICLES on Page #3*.

TOYOTA RAV-4 2001-02

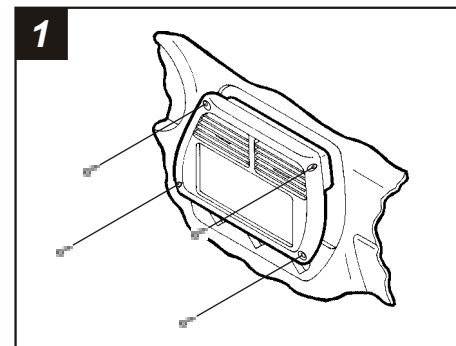

Disconnect the negative battery terminal to prevent an accidental short circuit. Remove (4) 3/16" Allen Screws from the radio trim bezel and remove the bezel. Remove (4) 10mm bolts securing the factory head unit and disconnect the wiring.

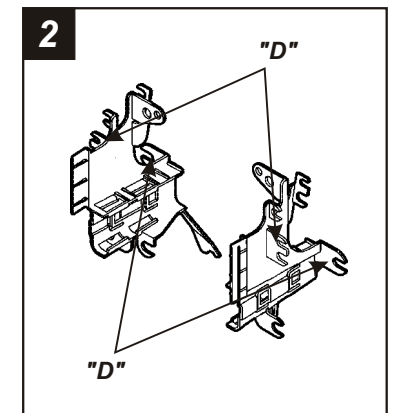

Cut and remove all tabs on the **Mounting Brackets** EXCEPT tabs "D". (The tabs can be identified by the stamped letter by each tab). Skip to the *Installation Instructions for ALL VEHICLES on Page #3*.