

KIT FEATURES

- ▶ ISO and DIN head unit provisions
- ▶ Pocket
- ▶ Rear Support

KIT COMPONENTS

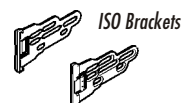
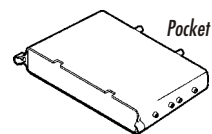
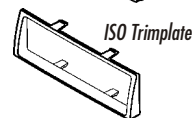
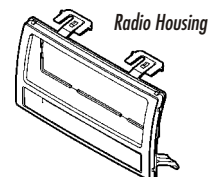

TOOLS REQUIRED



Phillips screwdriver

99-8203

INSTALLATION INSTRUCTIONS

APPLICATIONS

CAR	PAGE
TOYOTA	
Camry 2002-03.....	1-2



ALL VEHICLES

1

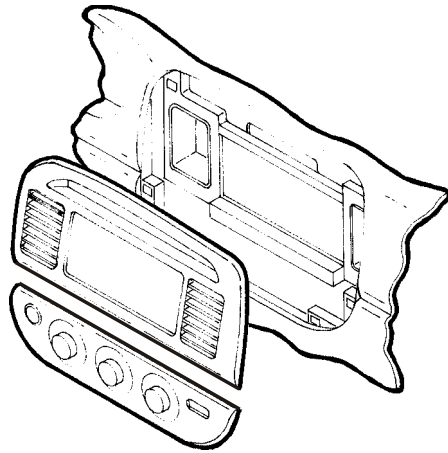

Disconnect the negative battery terminal to prevent an accidental short circuit. Unclip the climate control trim bezel and remove. Unclip the radio trim bezel and remove. Remove (4) 10mm hex-head screws securing the factory head unit and disconnect the wiring.

2

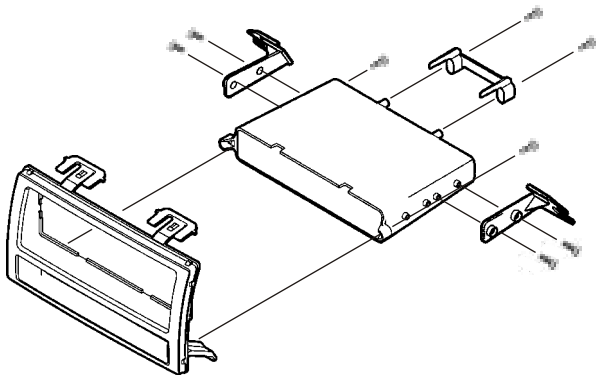

Secure the **Mounting Brackets** to the **Pocket** with (4) #6 x 1/4" Phillip Flat-head Screws supplied. Mount the **Pocket** to the back of the **Radio Housing** with (2) #8 x 3/8" Phillips Pan-head Screws supplied. Mount the **Rear Support Bracket** to the back of the Pocket with (2) #8 x 3/8" Phillips Pan-head Screws supplied.

1

3

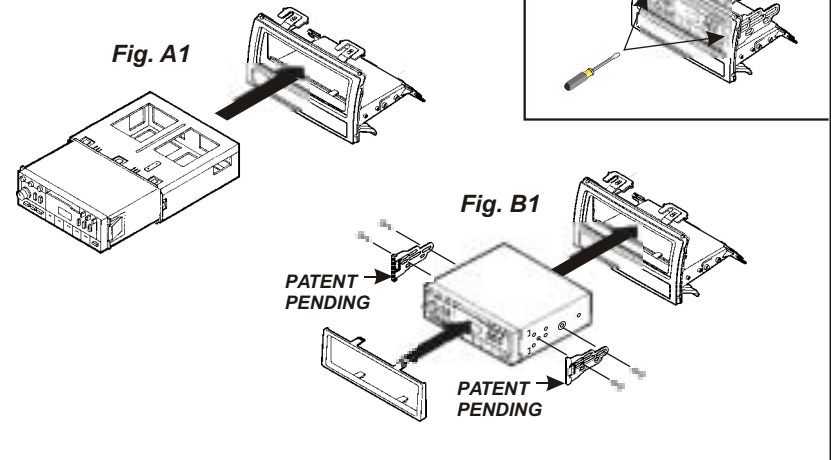

DIN HEAD UNITS: Slide the DIN cage into the **Radio Housing** and secure by bending the metal locking tabs down. Slide the aftermarket head unit into the cage and secure. (see Fig. A1)

ISO HEAD UNITS: Align the holes in the **ISO Brackets** with the holes in the head unit and mount the Brackets to the head unit with the screws supplied with the unit. Slide the head unit/bracket assembly into the radio opening until the side clips engage and snap the **ISO Trimplate** over the unit (see Fig. B1). **NOTE:** To remove the mounted head unit, unclip and remove the ISO Trimplate. Using a small flat-blade screwdriver, disengage the side clips securing the ISO Brackets to the Radio Housing (see Fig. B2).

4

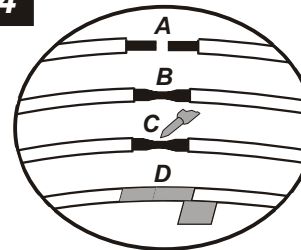

- A) Strip wire ends back 1/2"
- B) Twist ends together
- C) Solder
- D) Tape

Locate the factory wiring harness in the dash. Metra recommends using the proper mating adaptor and making connections as shown. (Isolate and individually tape off the ends of any unused wires to prevent electrical short circuit).

5

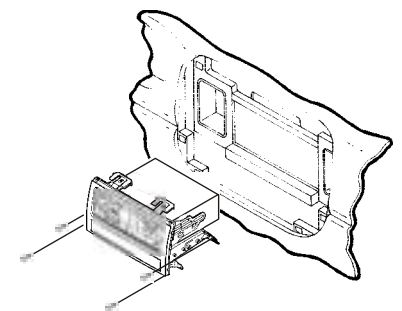

Re-connect the battery terminal and test the unit for proper operation. Mount the head unit/kit assembly to the sub-dash with (4) Phillips screws previously removed in step #1.

2