

**KIT COMPONENTS**

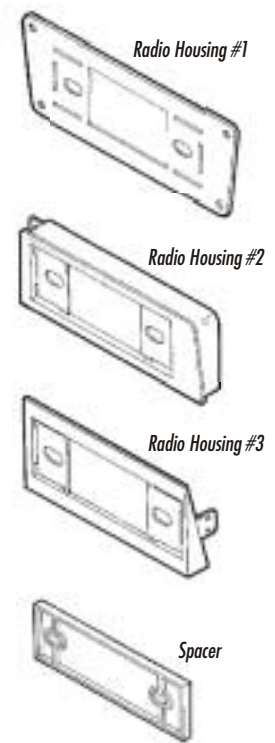

# 99-9222 INSTALLATION INSTRUCTIONS

**APPLICATIONS**

<b>CAR</b>	<b>PAGE</b>
<b>VOLVO</b>	
100 Series 1973-75.....	1
200 Series (lower dash) 1975-93.....	1
200 Series (upper dash) 1980-93.....	1
740 Series 1985-92.....	2
760 Series 1983-88.....	2

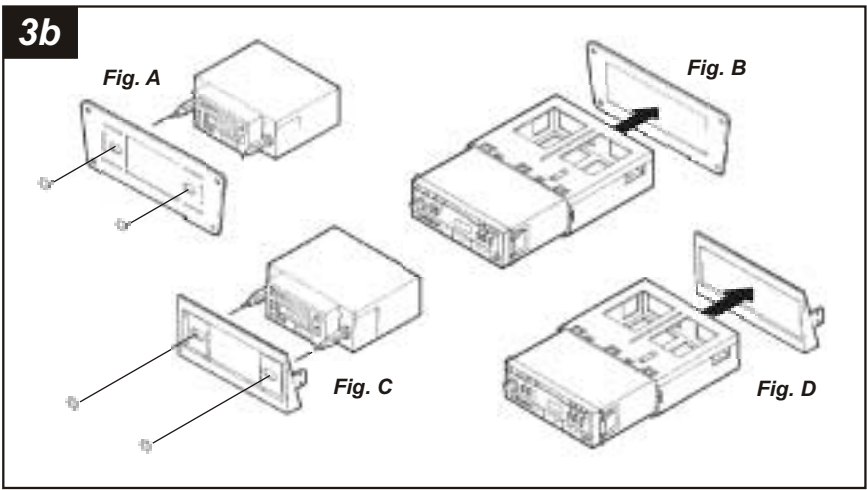

**200 SERIES (LOWER DASH), 100 SERIES:** For 2-Shaft head units, slide the aftermarket head unit into the **Radio Housing** and secure with shaft nuts. (see Fig. A). For DIN head units, cut and remove the shaft supports from the kit. Slide the DIN cage into the kit and secure by bending the metal locking tabs down. Slide the aftermarket head unit into the cage until secure. (see Fig. B)

**740 SERIES, 760 SERIES:** For 2-Shaft head units, slide the aftermarket head unit into the kit and secure with shaft nuts. (see Fig. C). For DIN head units, cut and remove the shaft supports from the **Radio Housing**. Slide the DIN cage into the kit and secure by bending the metal locking tabs down. Slide the aftermarket head unit into the cage until secure. (see Fig. D)

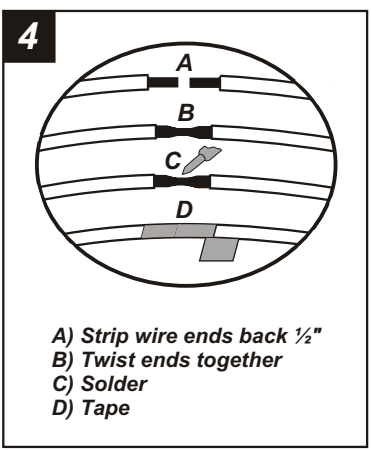

Locate the factory wiring harness in the dash. Metra recommends using the proper mating adaptor and making connections as shown. (Isolate and individually tape off the ends of any unused wires to prevent electrical short circuit).

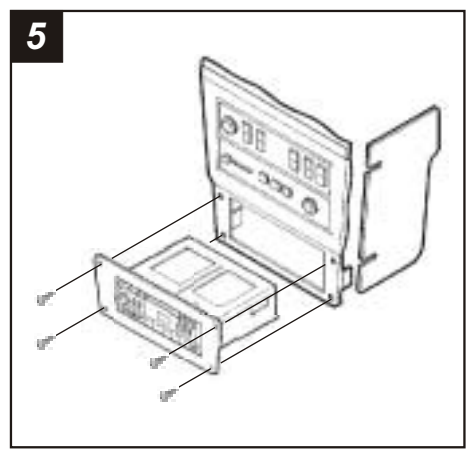

Re-connect the battery terminal and test the unit for proper operation. Mount the head unit/kit assembly to the sub-dash with those screws previously removed in step #1.

**TOOLS REQUIRED**



## VOLVO 100 Series 1973-75 200 Series (lower dash) 1975-93

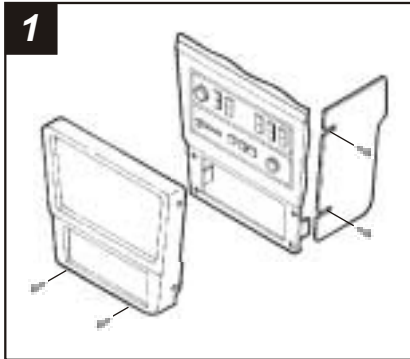

Disconnect the negative battery terminal to prevent an accidental short circuit. Remove (1) Phillips screw and (1) plastic twist-lock screw securing each side panel to the lower dash console. Remove (2) Phillips screws from the base of the radio trim bezel and remove the bezel. Remove (4) screws securing the factory pocket to the sub-dash and remove the pocket.

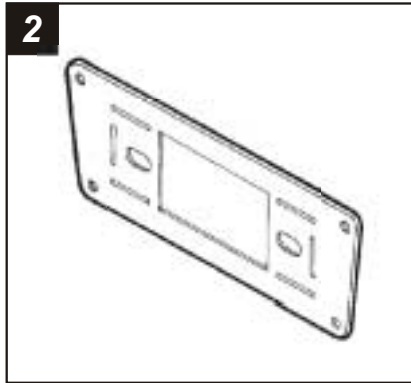

Locate **Radio Housing #1**. Skip to the *Installation Instructions for ALL VEHICLES on Page #3*.

## VOLVO 200 Series (upper dash) 1980-93

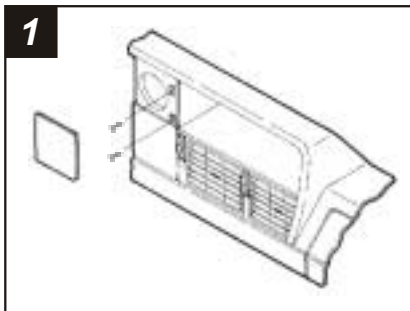

Disconnect the negative battery terminal to prevent an accidental short circuit. Unclip the square trim piece located to the left of the factory radio opening and remove (2) screws exposed. Open the glove box and remove (7) screws exposed in the glove box cavity. Remove the glove box assembly. Remove (1) screw securing the rear support to the factory head unit. Slide the head unit out and disconnect the wiring.

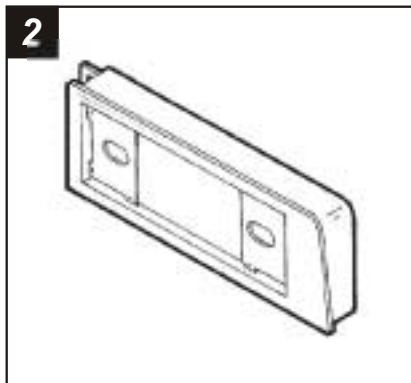

Locate **Radio Housing #2**. Skip to the *Installation Instructions for ALL VEHICLES on Page #2*.

## VOLVO 740 Series 1985-92 760 Series 1983-88

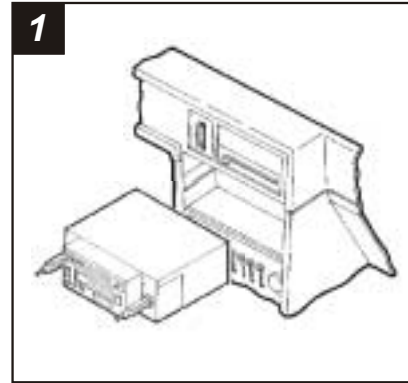

Disconnect the negative battery terminal to prevent an accidental short circuit. Remove (3) screws from the steering column inspection panel and lower the panel. Remove the factory radio knobs and shaft nuts. Insert a flat-blade screwdriver into the shaft wells and push in on the side springs. Pull the factory radio out and disconnect the wiring.

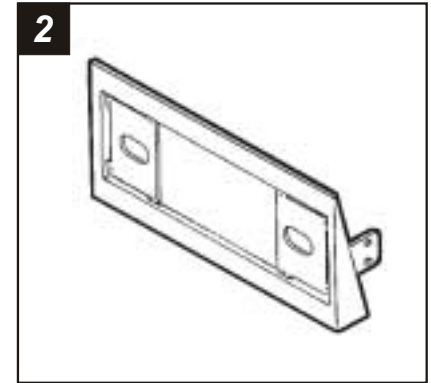

Locate **Radio Housing #3**. Skip to the *Installation Instructions for ALL VEHICLES on Page #3*.

## ALL VEHICLES

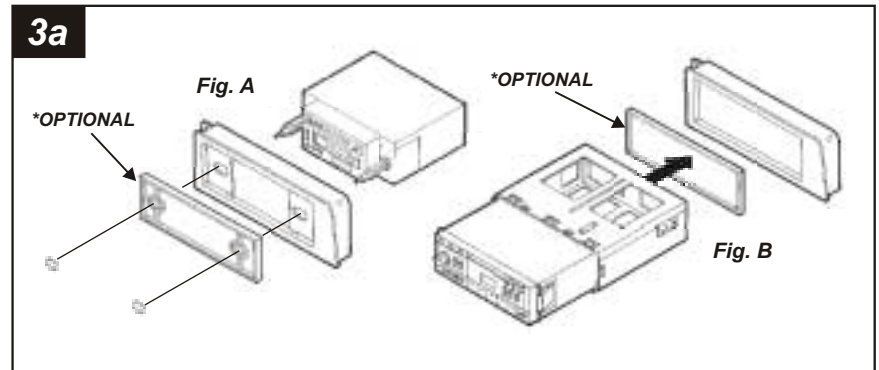

**200 SERIES (UPPER DASH):** For 2-Shaft head units, attach the **Spacer\*** to the **Radio Housing**. Slide the aftermarket head unit into the kit and secure with shaft nuts. (see Fig. A). For DIN head units, cut and remove the shaft supports from the **Spacer\*** and **Radio Housing**. Slide the DIN cage into the kit and secure by bending the metal locking tabs down. Slide the aftermarket head unit into the cage until secure. (see Fig. B)