

## KIT FEATURES

- ▶ Shaft and DIN unit provisions
- ▶ Equalizer provisions

## KIT COMPONENTS

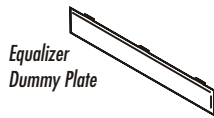

## TOOLS REQUIRED



# 99-3410 AW-341GO DW-3410 INSTALLATION INSTRUCTIONS

## APPLICATIONS

### CAR

#### CHEVROLET

Tracker 1998-02..... 1

#### GEO

Metro 1992-94..... 1

Tracker 1992-97..... 1

#### SUZUKI

Aerio 2003..... 2

Esteem 1995-02..... 2

Sidekick 1992-98..... 1

Swift 1992-94..... 1

Vitara series 1999-02..... 1

### PAGE

## CHEVROLET Tracker 1998-00 • GEO Tracker 1992-97 SUZUKI Sidekick 1992-98 / Vitara series 1999-02

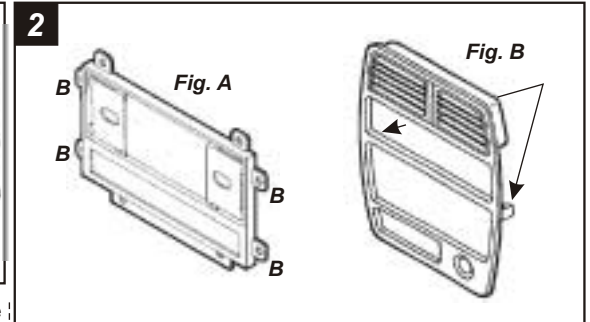
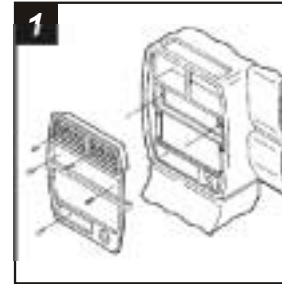

Disconnect the negative battery terminal to prevent an accidental short circuit. Remove the cigarette lighter and climate control knobs. Remove the ashtray and (1) screw exposed. Pull out on the climate control cluster and remove (2) screws exposed. Unclip the radio trim bezel. Remove (4) screws from the factory head unit, slide the unit out and disconnect the wiring.

Cut and remove all mounting tabs on the **Radio Housing** EXCEPT tabs "B". (The mounting tabs can be identified by the stamped letter on the back of each tab). (see Fig. A). Cut and remove the (2) side clips on the back side of the radio trim bezel. (This will provide proper clearance when re-attaching the bezel after the aftermarket head unit has been installed). (see Fig. B). Skip to the Installation Instructions for ALL VEHICLES on Page #3.

## GEO Metro / SUZUKI Swift 1992-94

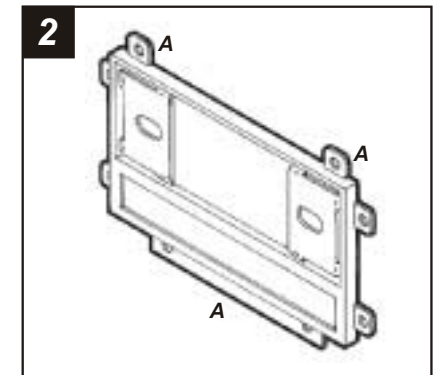
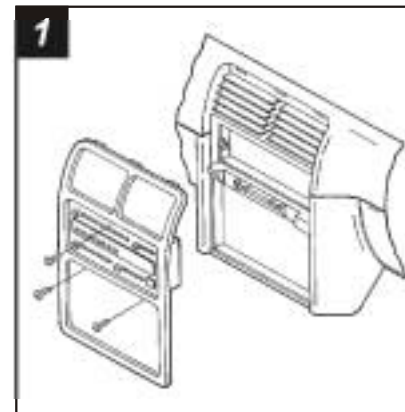

Disconnect the negative battery terminal to prevent an accidental short circuit. Remove the climate control knobs. Remove (1) Phillips screw above and (2) Phillips screws below the climate controls. Unclip the radio trim bezel. Remove (4) screws from the factory head unit, slide the unit out and disconnect the wiring.

Cut and remove all mounting tabs on the **Radio Housing** EXCEPT tabs "A". The mounting tabs can be identified by the stamped letter on the back of each tab. Skip to the Installation Instructions for ALL VEHICLES on Page #3.

## SUZUKI Aerio 2003

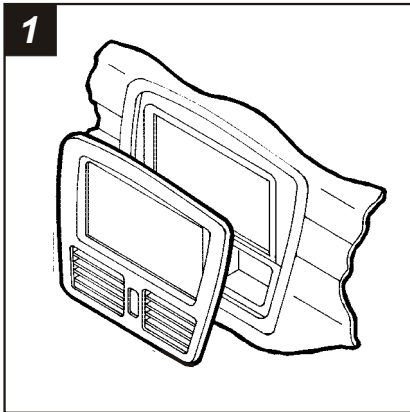

Disconnect the negative battery terminal to prevent an accidental short circuit. Unclip the dash trim bezel and remove. Remove (4) Phillips screws securing the factory head unit and disconnect the wiring.

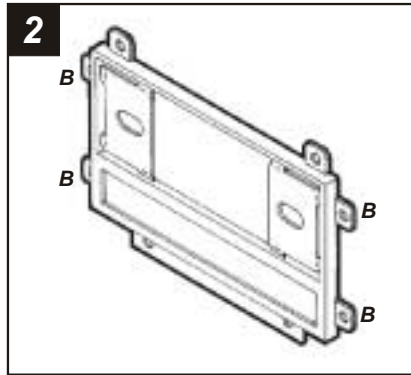

Cut and remove all mounting tabs on the **Radio Housing** EXCEPT tabs "B". The mounting tabs can be identified by the stamped letter on the back of each tab. Skip to the *Installation Instructions for ALL VEHICLES on Page #3*.

## SUZUKI Esteem 1995-02

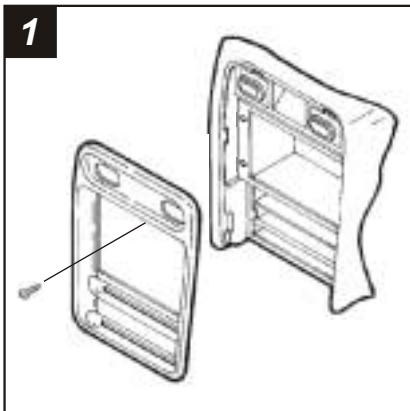

Disconnect the negative battery terminal to prevent an accidental short circuit. Remove the climate control knobs. Remove (1) Phillips screw located above the radio opening. Unclip the radio trim bezel. Remove (4) screws from the factory head unit, slide the unit out and disconnect the wiring.

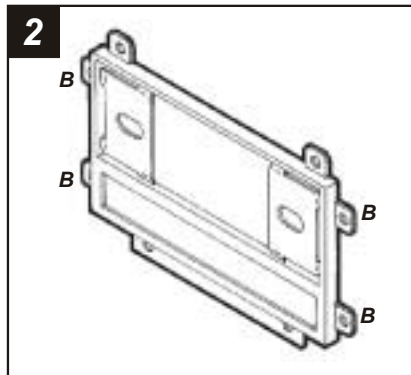

Cut and remove all mounting tabs on the **Radio Housing** EXCEPT tabs "B". The mounting tabs can be identified by the stamped letter on the back of each tab. Skip to the *Installation Instructions for ALL VEHICLES on Page #3*.

## ALL VEHICLES

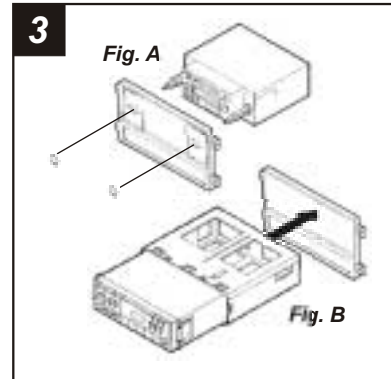

**2-SHAFT HEAD UNITS:** Slide the aftermarket head unit into the kit and secure with shaft nuts. (see Fig. A)

**DIN HEAD UNITS:** Cut and remove the shaft supports. Slide the DIN cage into the **Radio Housing** and secure by bending the metal locking tabs down. Slide the aftermarket head unit into the cage until secure. (see Fig. B)

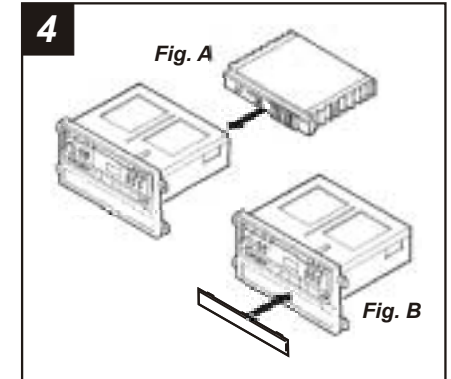

**IF AN EQUALIZER WILL BE INCLUDED :** Slide the aftermarket equalizer into the back of the **Radio Housing**. Using the hardware included with the equalizer, mount the unit to the kit. (see Fig. A)

**IF AN EQUALIZER WILL NOT BE INCLUDED:** Snap the **Equalizer Dummy Plate** into the **Radio Housing**. (see Fig. B)

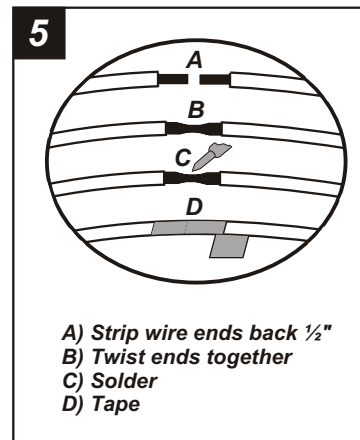

A) Strip wire ends back 1/2"  
B) Twist ends together  
C) Solder  
D) Tape

Locate the factory wiring harness in the dash. Metra recommends using the proper mating adaptor and making connections as shown. (Isolate and individually tape off the ends of any unused wires to prevent electrical short circuit).

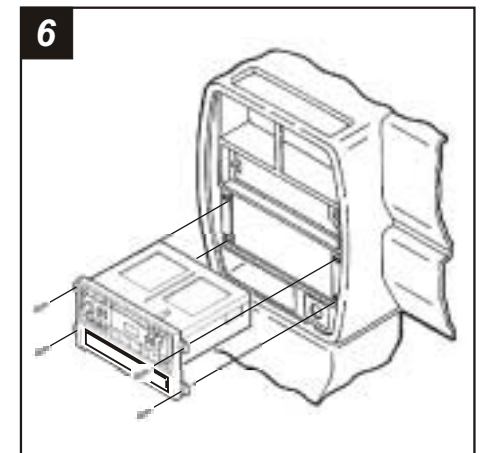

Re-connect the battery terminal and test the unit for proper operation. Slide (4) **Speed Clips** over the holes in the sub-dash mounting brackets and mount the head unit/kit assembly with (4) **Phillips Pan-Head Screws** supplied.