

ALL VEHICLES

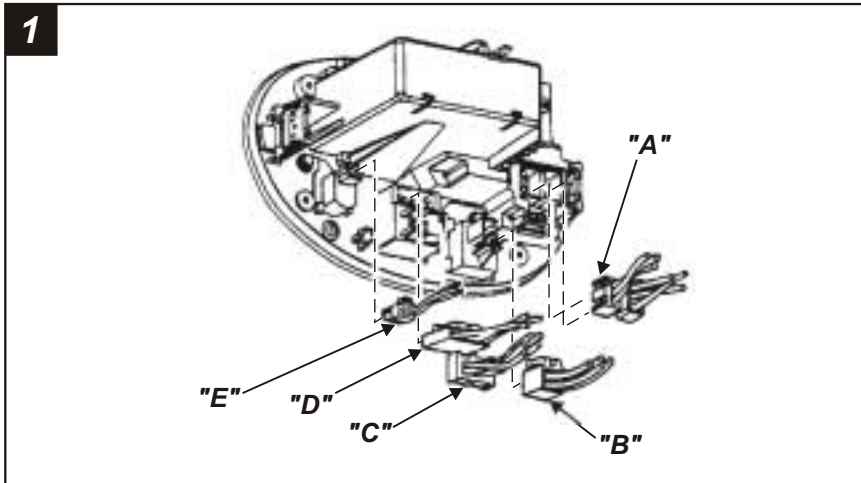

1 Disconnect the negative battery terminal to prevent an accidental short circuit. Using Metra's **86-5618**, pull the factory radio/climate control panel from the dash. Disconnect the audio system connectors ("A"), blower motor switch connector ("B"), vacuum hose harness ("C"), a/c damper door switch connector ("D"), and potentiometer connector ("E"). Remove the panel.

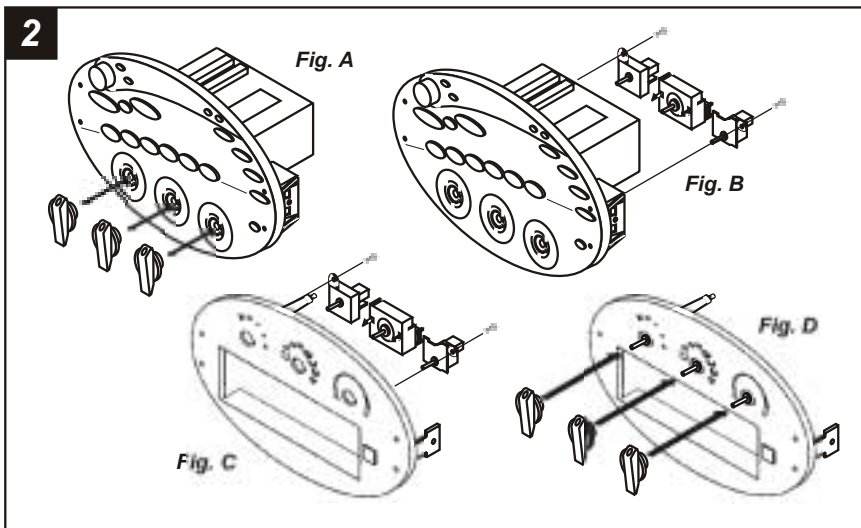

2 Turn the factory climate control dials into a vertical position and pull the dials off. (see Fig. A). Remove (2) hex-head screws securing the outer climate control switches and remove the switches. Unclip the center climate control switch and remove the switch. (see Fig. B). Mount the switches to the back of the **Integrated Mounting Kit** using the same hex-head screws. (see Fig. C). Holding the climate control dials in a vertical position, insert the dials onto the posts of the mounted switches and secure. (see Fig. D)

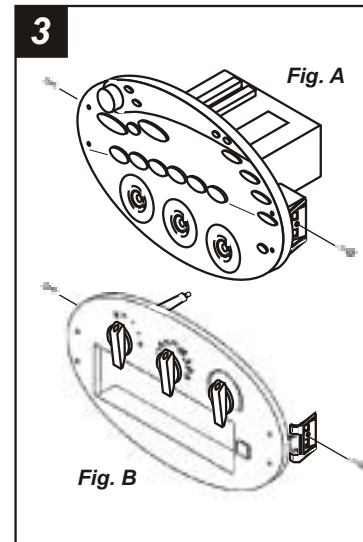

3 Remove (2) torx-head screws securing the mounting clips to the sides of the factory radio/climate control panel and remove the clips. (see Fig. A). Mount the clips to the **Integrated Mounting Kit** with the same torx-head screws. (see Fig. B)

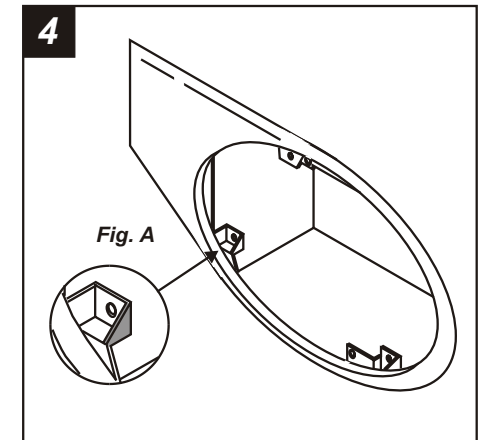

4 **FOR MODELS WITH BENCH SEATS:** Cut and remove the shaded portion of the support rib located in the bottom-left corner of the sub-dash. (see Fig. A).

FOR MODELS WITH BUCKET SEATS: Relocate the module in the sub-dash. Cut and remove 1/4" from the top of each bottom mounting tab in the sub-dash.

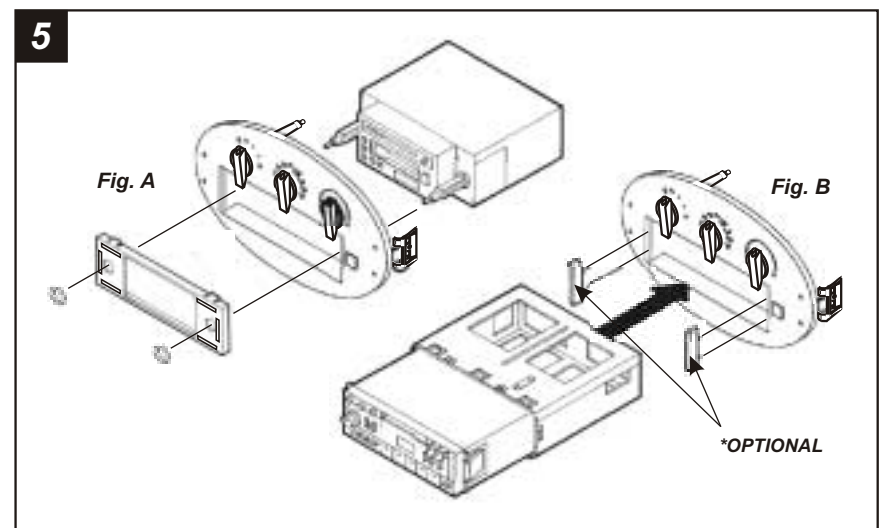

5 **2-SHAFT HEAD UNITS:** Snap the **Faceplate** into the **Integrated Mounting Kit**. Slide the aftermarket head unit into the kit and secure with shaft nuts. (see Fig. A)

DIN HEAD UNITS: Attach the **Snap Spacers*** to the outer walls of the radio opening. Slide the DIN cage into the **Integrated Mounting Kit** and secure by bending the metal locking tabs down. Slide the aftermarket head unit into the cage until secure. (see Fig. B)

99-5715C INSTALLATION INSTRUCTIONS

APPLICATIONS

CAR	PAGE
FORD	
Taurus 1996-99.....	1-3
MERCURY	
Sable 1996-99.....	1-3

NOTE: Metra's 70-5715 must be used with 1996-97 models
Metra's 70-5715 and 70-5716 must be used with 1998-99 models



KIT FEATURES

- ▶ Shaft and DIN unit provisions
- ▶ Various mounting depth alternatives
- ▶ Incorporates factory climate controls into installation

KIT COMPONENTS

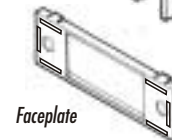
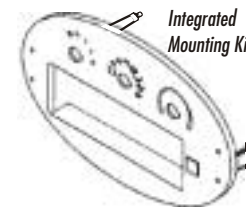

TOOLS REQUIRED



86-5618 - Head unit removal keys



Torx-head screwdriver



Dremel tool

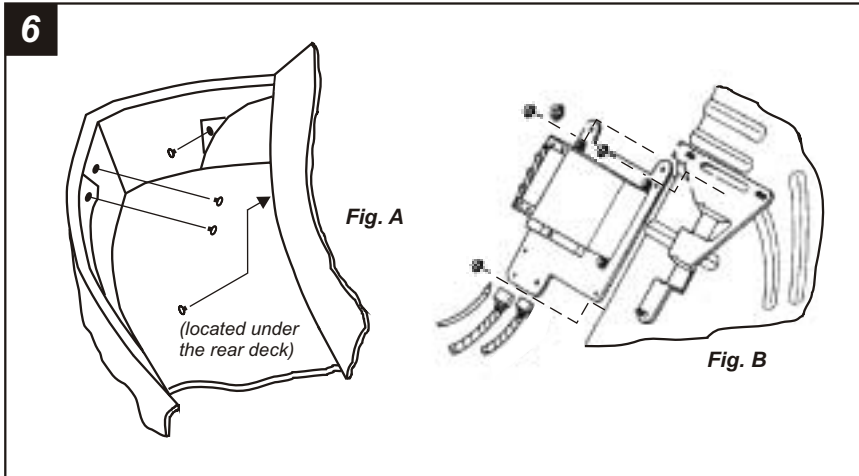

Open the trunk, remove (4) pop-clips from the driver's side trunk liner and remove the liner. (see Fig. A). Locate the factory tuner on the wall of the trunk and disconnect the speaker and antenna plugs (it is NOT necessary to remove the tuner). (see Fig. B). Plug the speaker extension lead into the unit speaker plug and the antenna extension lead into the unit antenna plug. Slide the extension harness through the space in the back seat between the seat back and seat bottom. Unclip the rocker trim, tuck the extension harness under the carpet and stretch the harness to the back of the dash. (Replace the rocker trim when completed). Splice the speaker leads on the extension harness into the rear of the aftermarket head unit. Plug the factory wiring harnesses into the switch connectors (previously mounted in step #2) and audio connectors on the back of the **Integrated Mounting Kit**.

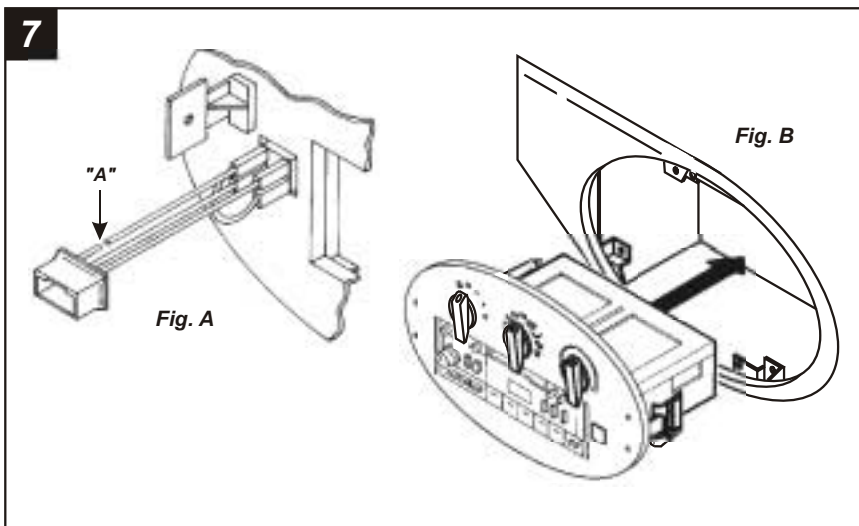

Re-connect the battery terminal and test the unit, climate controls and rear defroster for proper operation. (If the rear defroster does not work, cut the black wire on the switch plug at position "A" and connect the wire extending from the rear defroster switch to ground. (see Fig. A). Snap the **Integrated Mounting Kit** assembly into the sub-dash. (see Fig. B)

ALL VEHICLES

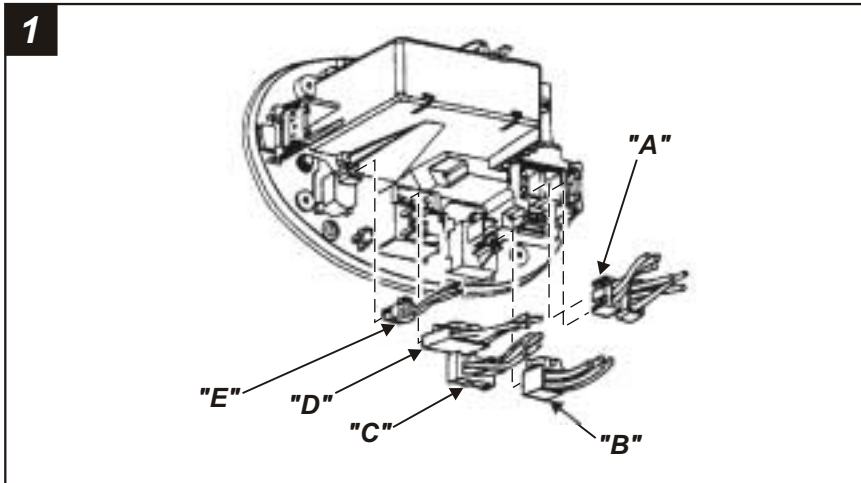

1 Disconnect the negative battery terminal to prevent an accidental short circuit. Using Metra's **86-5618**, pull the factory radio/climate control panel from the dash. Disconnect the audio system connectors ("A"), blower motor switch connector ("B"), vacuum hose harness ("C"), a/c damper door switch connector ("D"), and potentiometer connector ("E"). Remove the panel.

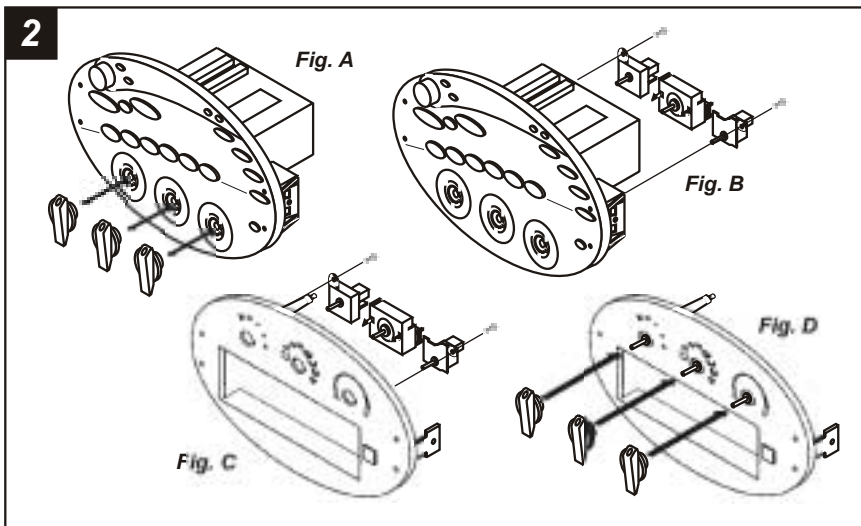

2 Turn the factory climate control dials into a vertical position and pull the dials off. (see Fig. A). Remove (2) hex-head screws securing the outer climate control switches and remove the switches. Unclip the center climate control switch and remove the switch. (see Fig. B). Mount the switches to the back of the **Integrated Mounting Kit** using the same hex-head screws. (see Fig. C). Holding the climate control dials in a vertical position, insert the dials onto the posts of the mounted switches and secure. (see Fig. D)

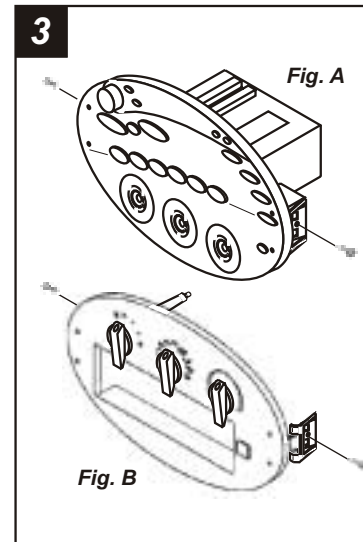

3 Remove (2) torx-head screws securing the mounting clips to the sides of the factory radio/climate control panel and remove the clips. (see Fig. A). Mount the clips to the **Integrated Mounting Kit** with the same torx-head screws. (see Fig. B)

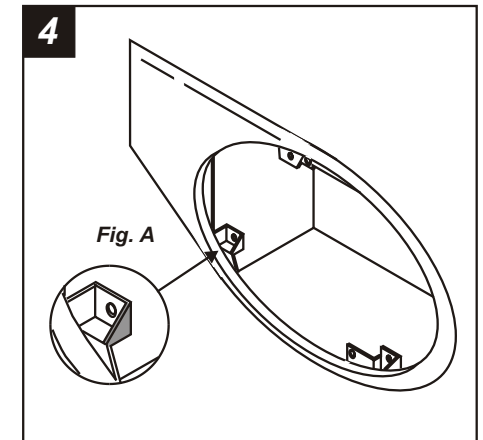

4 **FOR MODELS WITH BENCH SEATS:** Cut and remove the shaded portion of the support rib located in the bottom-left corner of the sub-dash. (see Fig. A).

FOR MODELS WITH BUCKET SEATS: Relocate the module in the sub-dash. Cut and remove 1/4" from the top of each bottom mounting tab in the sub-dash.

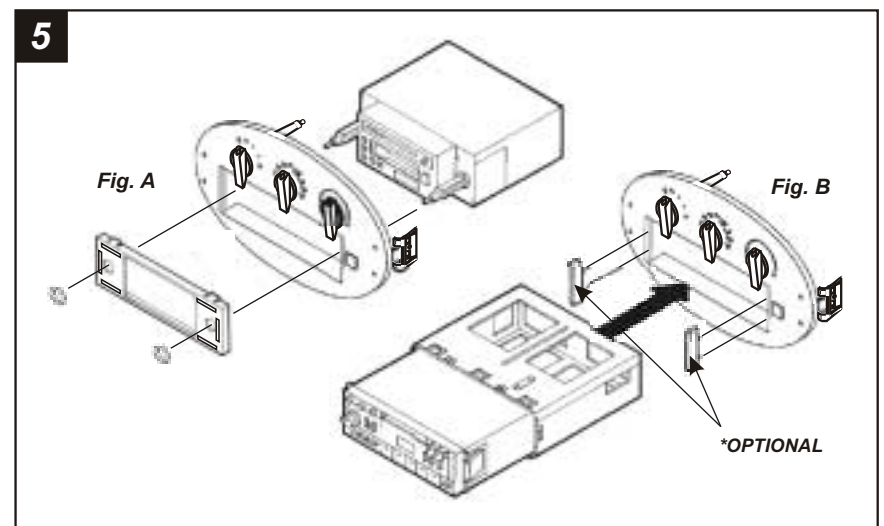

5 **2-SHAFT HEAD UNITS:** Snap the **Faceplate** into the **Integrated Mounting Kit**. Slide the aftermarket head unit into the kit and secure with shaft nuts. (see Fig. A)

DIN HEAD UNITS: Attach the **Snap Spacers*** to the outer walls of the radio opening. Slide the DIN cage into the **Integrated Mounting Kit** and secure by bending the metal locking tabs down. Slide the aftermarket head unit into the cage until secure. (see Fig. B)

6

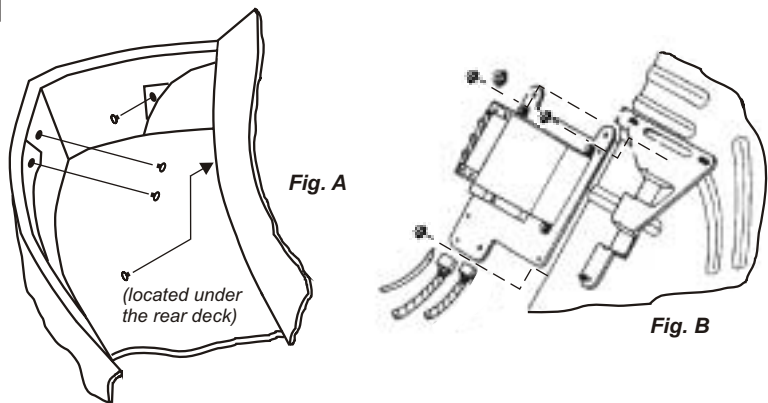

Open the trunk, remove (4) pop-clips from the driver's side trunk liner and remove the liner. (see Fig. A). Locate the factory tuner on the wall of the trunk and disconnect the speaker and antenna plugs (it is NOT necessary to remove the tuner). (see Fig. B). Plug the speaker extension lead into the unit speaker plug and the antenna extension lead into the unit antenna plug. Slide the extension harness through the space in the back seat between the seat back and seat bottom. Unclip the rocker trim, tuck the extension harness under the carpet and stretch the harness to the back of the dash. (Replace the rocker trim when completed). Splice the speaker leads on the extension harness into the rear of the aftermarket head unit. Plug the factory wiring harnesses into the switch connectors (previously mounted in step #2) and audio connectors on the back of the **Integrated Mounting Kit**.

7

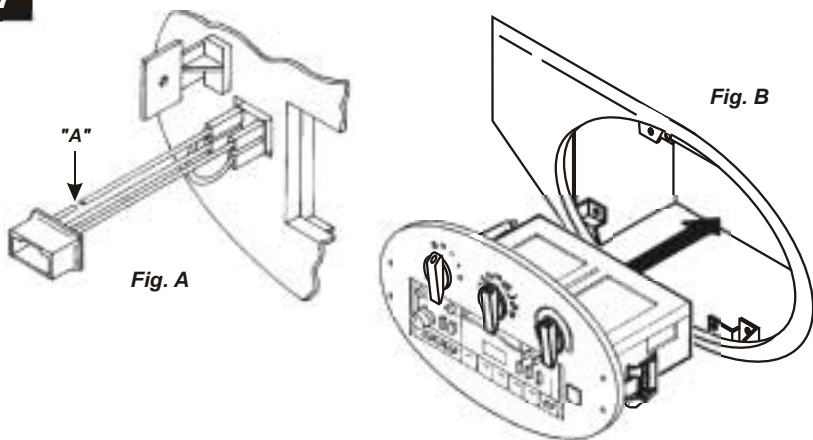

Re-connect the battery terminal and test the unit, climate controls and rear defroster for proper operation. (If the rear defroster does not work, cut the black wire on the switch plug at position "A" and connect the wire extending from the rear defroster switch to ground. (see Fig. A). Snap the **Integrated Mounting Kit** assembly into the sub-dash. (see Fig. B)

KIT FEATURES

- ▶ Shaft and DIN unit provisions
- ▶ Various mounting depth alternatives
- ▶ Incorporates factory climate controls into installation

KIT COMPONENTS

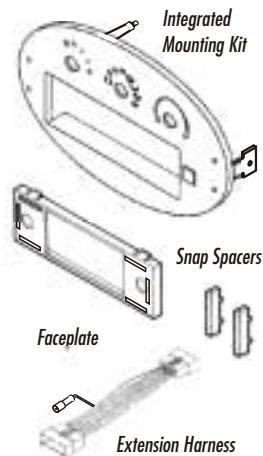

TOOLS REQUIRED



99-5715LD

INSTALLATION INSTRUCTIONS

APPLICATIONS

CAR	PAGE
FORD	
Taurus 1996-97.....	1-3
MERCURY	
Sable 1996-97.....	1-3

NOTE: Metra's 70-5715 must be used with 1996-97 models
Metra's 70-5716 must be used with 1998-99 models

METRA/EIA Wiring Color Code

12 Volt.....	Red
Memory.....	Yellow
Ground.....	Black *
Power Antenna.....	Blue
Amp remote.....	Blue / White
Illumination.....	Orange
Dimmer.....	Orange / White
Grounding Dimmer.....	Orange / Black
Right Front (+).....	Gray
Right Front (-).....	Gray / Black
Left Front (+).....	White
Left Front (-).....	White / Black
Right Rear (+).....	Violet
Right Rear (-).....	Violet / Black
Left Rear (+).....	Green
Left Rear (-).....	Green / Black

* NOTE: Ground head unit to vehicle chassis when Black wire is not present.

KIT FEATURES

- ▶ Shaft and DIN unit provisions
- ▶ Incorporates factory climate controls into installation

KIT COMPONENTS

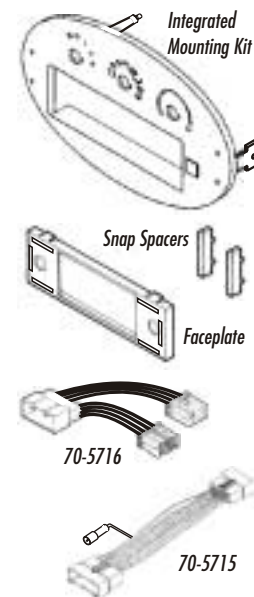

TOOLS REQUIRED

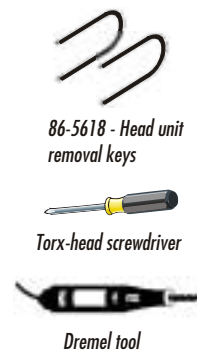

99-5715LDS

INSTALLATION INSTRUCTIONS

APPLICATIONS

CAR	PAGE
FORD	
Taurus 1998-99.....	1-6
MERCURY	
Sable 1998-99.....	1-6

METRA/EIA Wiring Color Code

12 Volt.....	Red
Memory.....	Yellow
Ground.....	Black *
Power Antenna.....	Blue
Amp remote.....	Blue / White
Illumination.....	Orange
Dimmer.....	Orange / White
Grounding Dimmer.....	Orange / Black
Right Front (+).....	Gray
Right Front (-).....	Gray / Black
Left Front (+).....	White
Left Front (-).....	White / Black
Right Rear (+).....	Violet
Right Rear (-).....	Violet / Black
Left Rear (+).....	Green
Left Rear (-).....	Green / Black

* NOTE: Ground head unit to vehicle chassis when Black wire is not present.

ALL VEHICLES

NOTES: _____

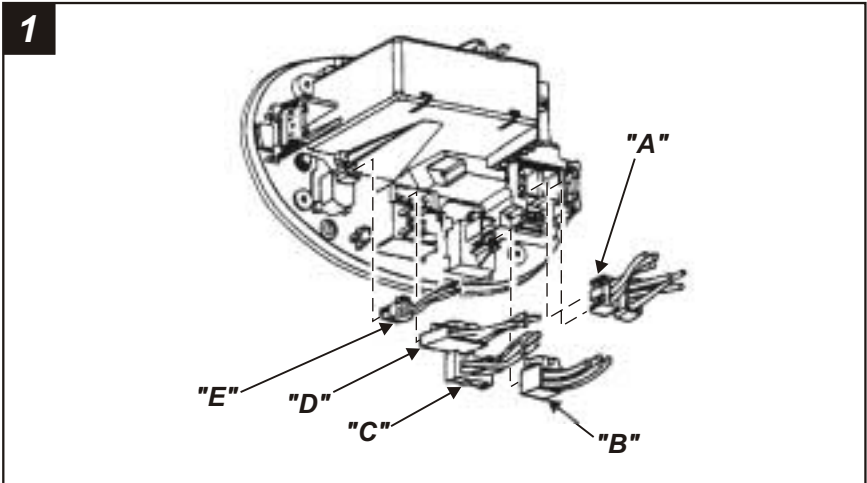

Disconnect the negative battery terminal to prevent an accidental short circuit. Using Metra's **86-5618**, pull the factory radio/climate control panel from the dash. Disconnect the audio system connectors (**"A"**), blower motor switch connector (**"B"**), vacuum hose harness (**"C"**), a/c damper door switch connector (**"D"**), and potentiometer connector (**"E"**). Remove the panel.

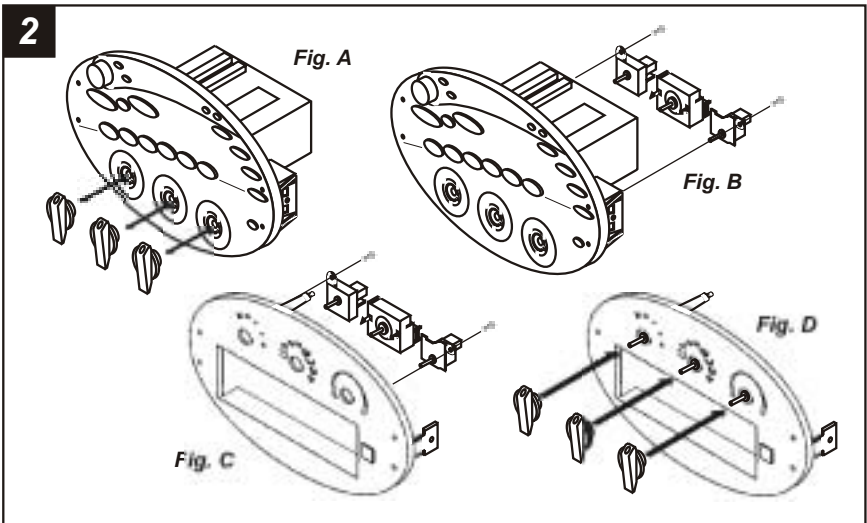

Turn the factory climate control dials into a vertical position and pull the dials off. (see Fig. A). Remove (2) hex-head screws securing the outer climate control switches and remove the switches. Unclip the center climate control switch and remove the switch. (see Fig. B). Mount the switches to the back of the **Integrated Mounting Kit** using the same hex-head screws. (see Fig. C). Holding the climate control dials in a vertical position, insert the dials onto the posts of the mounted switches and secure. (see Fig. D)

8

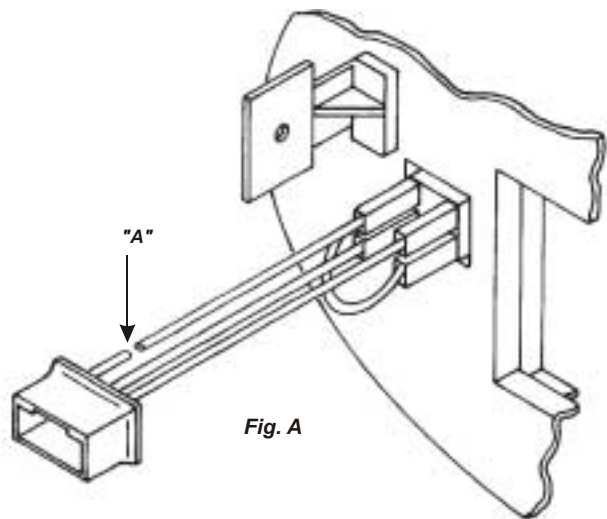

Fig. A

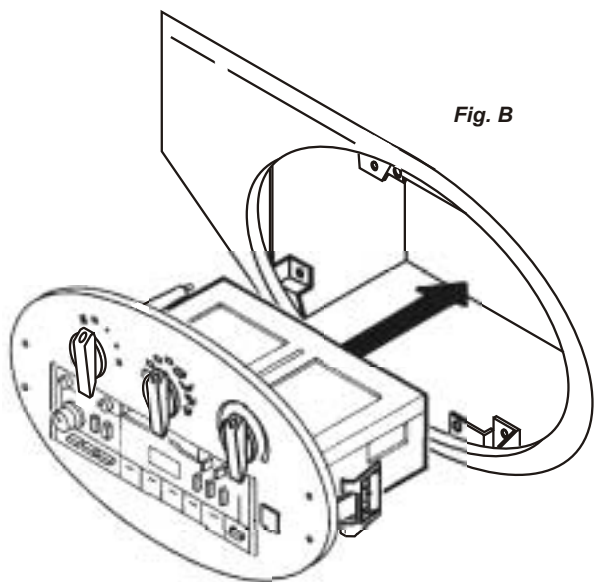

Fig. B

Re-connect the battery terminal and test the unit, climate controls and rear defroster for proper operation. (If the rear defroster does not work, cut the black wire on the switch plug at position "A" and connect the wire extending from the rear defroster switch to ground. (see Fig. A). Snap the **Integrated Mounting Kit** assembly into the sub-dash. (see Fig. B)

5

3

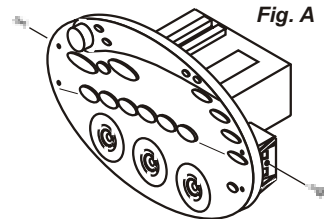

Fig. A

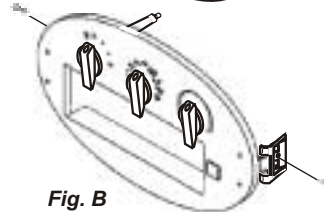

Fig. B

Remove (2) torx-head screws securing the mounting clips to the sides of the factory radio/climate control panel and remove the clips. (see Fig. A). Mount the clips to the **Integrated Mounting Kit** with the same torx-head screws. (see Fig. B)

4

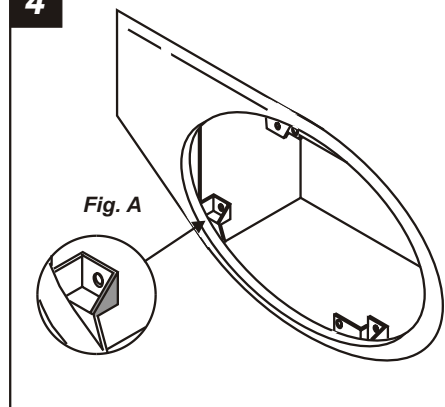

Fig. A

FOR MODELS WITH BENCH SEATS: Cut and remove the shaded portion of the support rib located in the bottom-left corner of the sub-dash. (see Fig. A).

FOR MODELS WITH BUCKET SEATS: Relocate the module in the sub-dash. Cut and remove 1/4" from the top of each bottom mounting tab in the sub-dash.

5

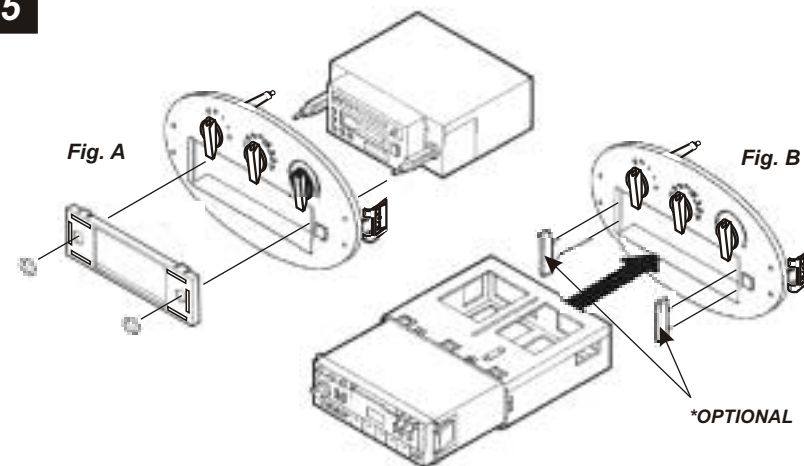

Fig. A

Fig. B

*OPTIONAL

2-SHAFT HEAD UNITS: Snap the **Faceplate** into the **Integrated Mounting Kit**. Slide the aftermarket head unit into the kit and secure with shaft nuts. (see Fig. A)

DIN HEAD UNITS: Attach the **Snap Spacers*** to the outer walls of the radio opening. Slide the DIN cage into the **Integrated Mounting Kit** and secure by bending the metal locking tabs down. Slide the aftermarket head unit into the cage until secure. (see Fig. B)

2

6

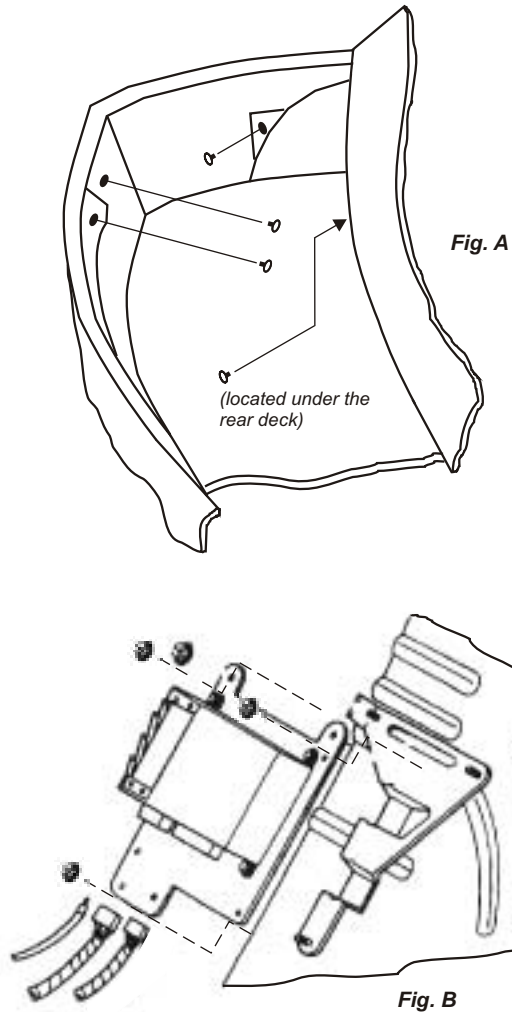

Open the trunk, remove (4) pop-clips from the driver's side trunk liner and remove the liner. (see Fig. A). Locate the factory tuner on the wall of the trunk and disconnect the speaker and antenna plugs (it is NOT necessary to remove the tuner). (see Fig. B). Plug the speaker extension lead into the unit speaker plug and the antenna extension lead into the unit antenna plug. Slide the extension harness through the space in the back seat between the seat back and seat bottom. Unclip the rocker trim, tuck the extension harness under the carpet and stretch the harness to the back of the dash. (Replace the rocker trim when completed). Splice the speaker leads on the extension harness into the rear of the aftermarket head unit. Plug the factory wiring harnesses into the switch connectors (previously mounted in step #2) and audio connectors on the back of the **Integrated Mounting Kit**.

3

7

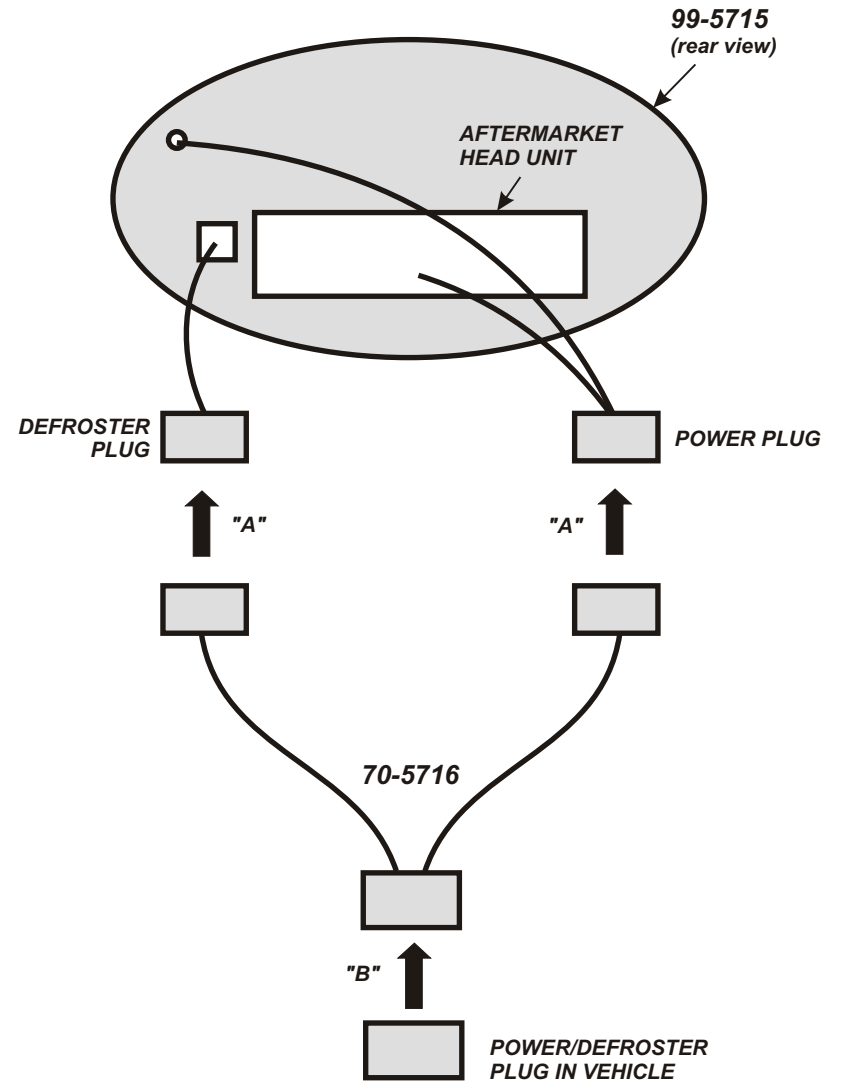

1998-99 MODELS: Attach the **Defroster Plug** and **Power Plug** on the back of the 99-5715 to the corresponding plugs on the 70-5716 ("A"). Attach the **Power/Defroster Plug** in the vehicle to the corresponding plug on the 70-5716 ("B").

1996-97 MODELS: Skip to step #8 on Page 5.

4

ALL VEHICLES

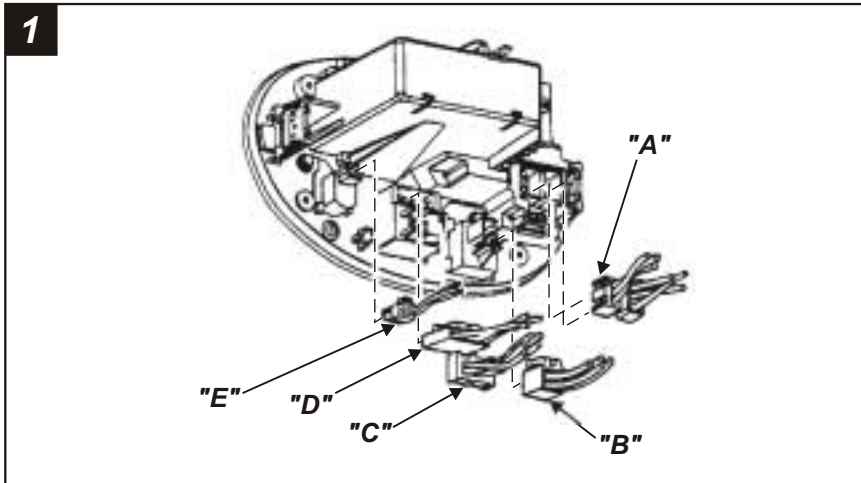

1 Disconnect the negative battery terminal to prevent an accidental short circuit. Using Metra's **86-5618**, pull the factory radio/climate control panel from the dash. Disconnect the audio system connectors ("A"), blower motor switch connector ("B"), vacuum hose harness ("C"), a/c damper door switch connector ("D"), and potentiometer connector ("E"). Remove the panel.

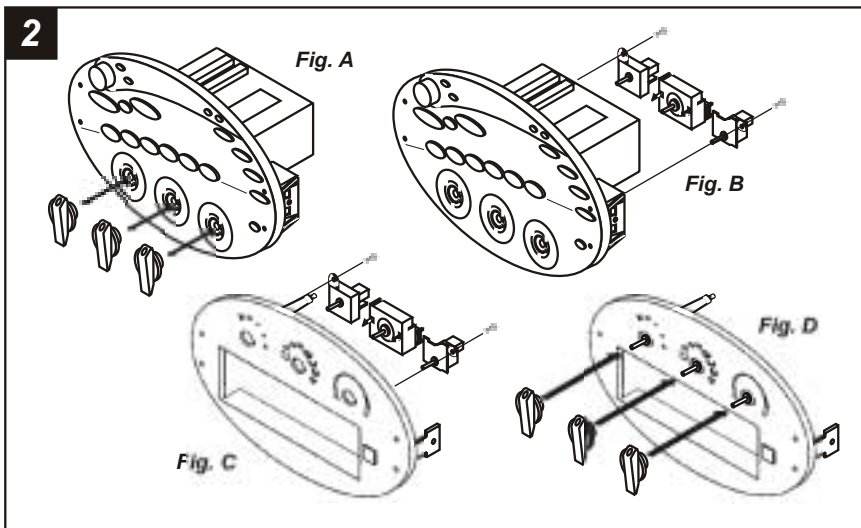

2 Turn the factory climate control dials into a vertical position and pull the dials off. (see Fig. A). Remove (2) hex-head screws securing the outer climate control switches and remove the switches. Unclip the center climate control switch and remove the switch. (see Fig. B). Mount the switches to the back of the **Integrated Mounting Kit** using the same hex-head screws. (see Fig. C). Holding the climate control dials in a vertical position, insert the dials onto the posts of the mounted switches and secure. (see Fig. D)

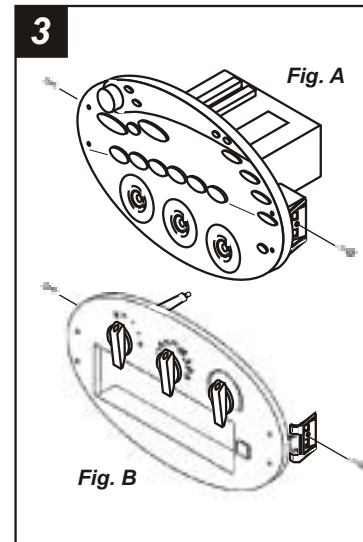

3 Remove (2) torx-head screws securing the mounting clips to the sides of the factory radio/climate control panel and remove the clips. (see Fig. A). Mount the clips to the **Integrated Mounting Kit** with the same torx-head screws. (see Fig. B)

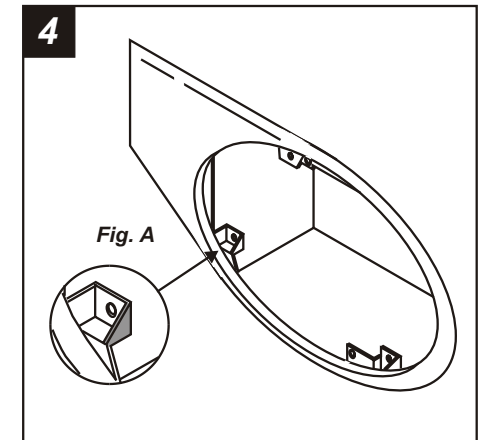

4 **FOR MODELS WITH BENCH SEATS:** Cut and remove the shaded portion of the support rib located in the bottom-left corner of the sub-dash. (see Fig. A). **FOR MODELS WITH BUCKET SEATS:** Relocate the module in the sub-dash. Cut and remove 1/4" from the top of each bottom mounting tab in the sub-dash.

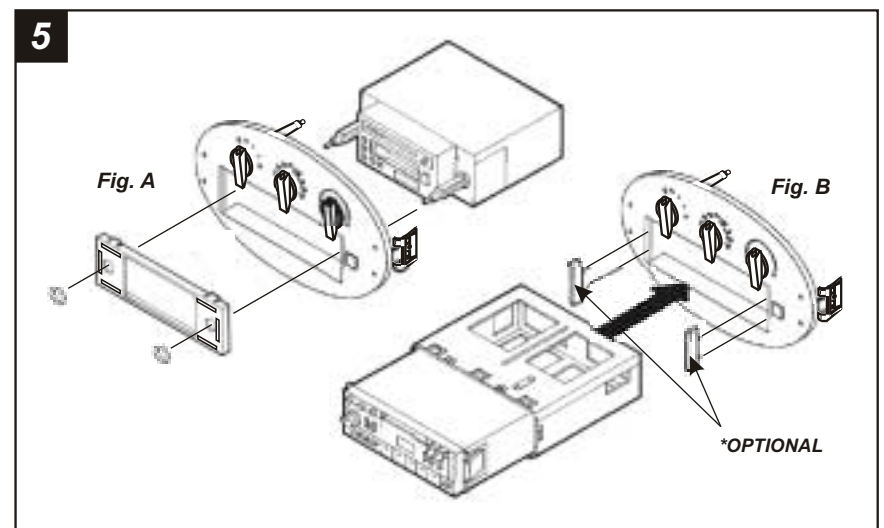

5 **2-SHAFT HEAD UNITS:** Snap the **Faceplate** into the **Integrated Mounting Kit**. Slide the aftermarket head unit into the kit and secure with shaft nuts. (see Fig. A)

DIN HEAD UNITS: Attach the **Snap Spacers*** to the outer walls of the radio opening. Slide the DIN cage into the **Integrated Mounting Kit** and secure by bending the metal locking tabs down. Slide the aftermarket head unit into the cage until secure. (see Fig. B)

6

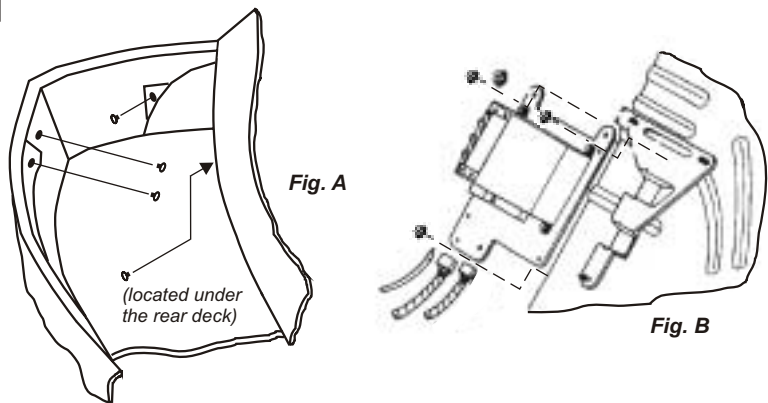

Open the trunk, remove (4) pop-clips from the driver's side trunk liner and remove the liner. (see Fig. A). Locate the factory tuner on the wall of the trunk and disconnect the speaker and antenna plugs (it is NOT necessary to remove the tuner). (see Fig. B). Plug the speaker extension lead into the unit speaker plug and the antenna extension lead into the unit antenna plug. Slide the extension harness through the space in the back seat between the seat back and seat bottom. Unclip the rocker trim, tuck the extension harness under the carpet and stretch the harness to the back of the dash. (Replace the rocker trim when completed). Splice the speaker leads on the extension harness into the rear of the aftermarket head unit. Plug the factory wiring harnesses into the switch connectors (previously mounted in step #2) and audio connectors on the back of the **Integrated Mounting Kit**.

7

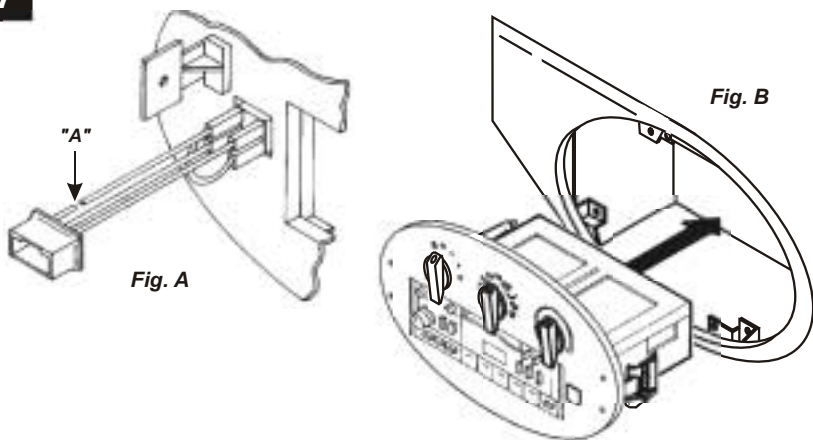

Re-connect the battery terminal and test the unit, climate controls and rear defroster for proper operation. (If the rear defroster does not work, cut the black wire on the switch plug at position "A" and connect the wire extending from the rear defroster switch to ground. (see Fig. A). Snap the **Integrated Mounting Kit** assembly into the sub-dash. (see Fig. B)

KIT FEATURES

- ▶ Shaft and DIN unit provisions
- ▶ Various mounting depth alternatives
- ▶ Incorporates factory climate controls into installation

KIT COMPONENTS

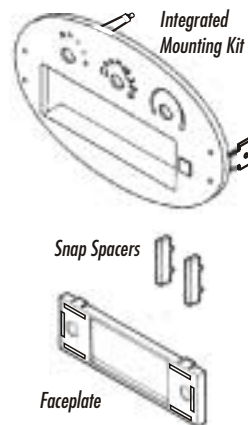

TOOLS REQUIRED

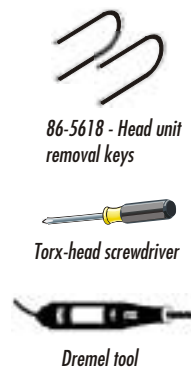

99-5715 INSTALLATION INSTRUCTIONS

APPLICATIONS

CAR	PAGE
FORD	
Taurus 1996-99.....	1-3
MERCURY	
Sable 1996-99.....	1-3

NOTE: Metra's 70-5715 must be used with 1996-97 models
Metra's 70-5715 and 70-5716 must be used with 1998-99 models

