

**FORD Explorer 1995-00 / Ranger 1995-00 / Windstar 1999-03
MAZDA B-Series Pickup 1995-00 / Mountaineer 1997-00**

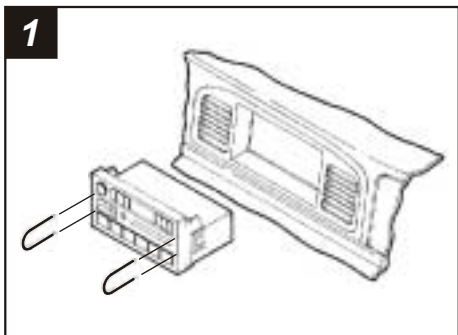

1
Disconnect the negative battery terminal to prevent an accidental short circuit. Using Metra's **86-5618**, pull the factory head unit from the dash and disconnect the wiring.

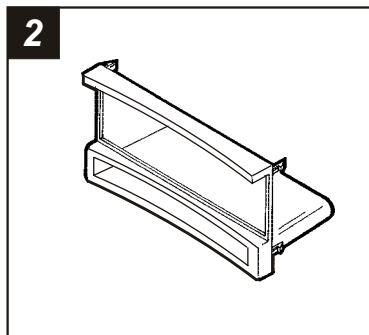

2
Locate **Radio Housing "A"**. Skip to the *Installation Instructions for ALL VEHICLES on Page #2*.

ALL VEHICLES

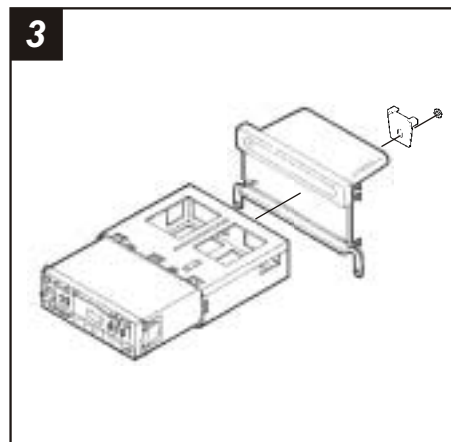

3
Slide the DIN cage into the **Radio Housing** and secure by bending the metal locking tabs down. Slide the aftermarket head unit into the cage until secure. Mount the **Rear Support** to the back of the head unit using the hardware included with the unit.

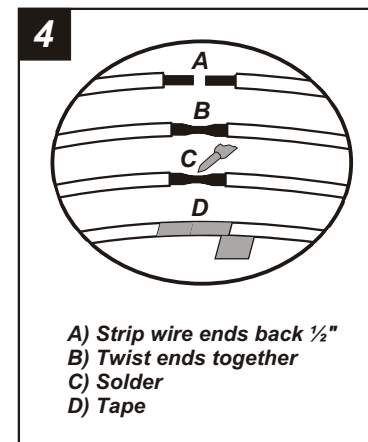

4
A) Strip wire ends back 1/2"
B) Twist ends together
C) Solder
D) Tape

Locate the factory wiring harness in the dash. Metra recommends using the proper mating adaptor and making connections as shown. (Isolate and individually tape off the ends of any unused wires to prevent electrical short circuit).

**FORD Expedition / F-150 1999-00 / FORD Excursion 2000-03
LINCOLN Navigator 1998-00 / Blackwood 2001**

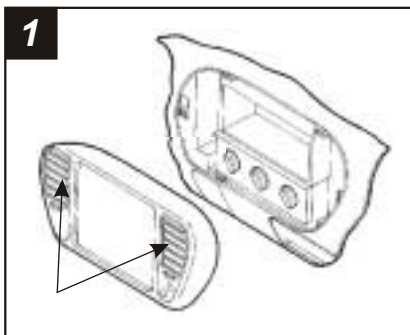

1
Disconnect the negative battery terminal to prevent an accidental short circuit. Place your index fingers on the inner edges of the a/c vents (shown above) and push inward. Grasp the exposed lip of each vent opening and pull out on the radio trim bezel. Remove the dash trim bezel. (The airbag wiring does NOT need to be disconnected). Using Metra's **86-5618**, pull the factory head unit from the dash and disconnect the wiring.

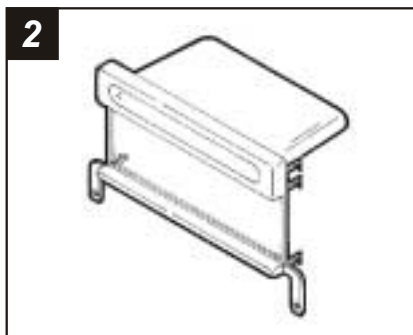

2
Locate **Radio Housing "B"**. Skip to the *Installation Instructions for ALL VEHICLES on Page #2*.

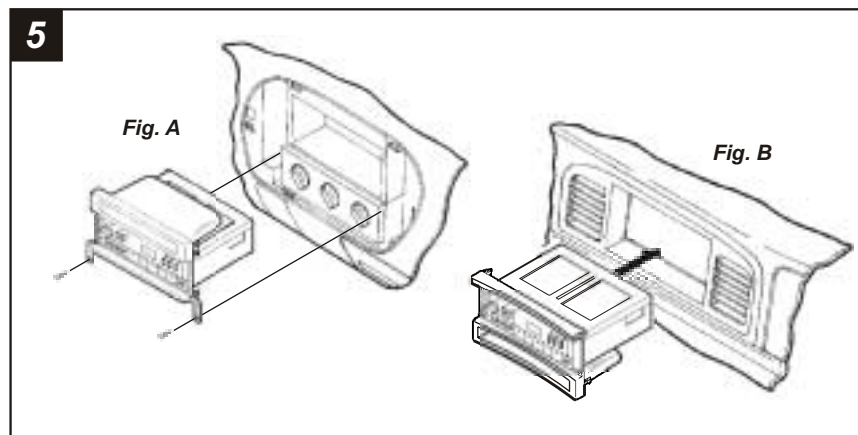

5
EXPEDITION, F-150, NAVIGATOR: Re-connect the battery terminal and test the unit for proper operation. Remove the top (2) Phillips screws securing the climate control cluster to the sub-dash. Slide the head unit/kit assembly into the dash cavity and mount the bottom legs of the kit to the same holes in the climate control cluster with the (2) Phillips screws previously removed. (see Fig. A)

B-SERIES PICKUP, EXPLORER, MOUNTAINEER, RANGER: Re-connect the battery terminal and test the unit for proper operation. Snap the head unit/kit assembly into the sub-dash. (see Fig. B)

KIT FEATURES

- ▶ Rear support provisions
- ▶ CD jewel case pocket

KIT COMPONENTS

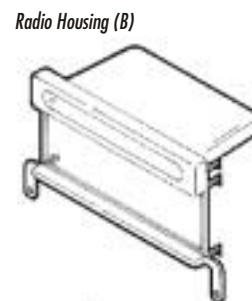
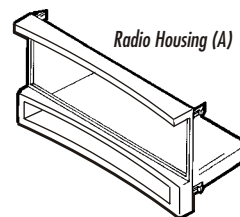

(2) Rear Supports

TOOLS REQUIRED



86-5618 - Head unit removal keys



Phillips screwdriver

99-5804 AW-586FT INSTALLATION

APPLICATIONS

CAR	PAGE
FORD	
Expedition 1999-02.....	1
Explorer 1995-01.....	1
F-150 1999-03.....	1
Ranger 1995-03.....	1
Windstar 1999-03.....	1
LINCOLN	
Blackwood 2001.....	1
Excursion 2000-03.....	1
Navigator 1998-00.....	1
MAZDA	
B-Series Pickup 1995-02.....	1
MERCURY	
Mountaineer 1997-01.....	1