

CHRYSLER 300M 1999-03 / Concorde 1998-03 / LHS 1998-03

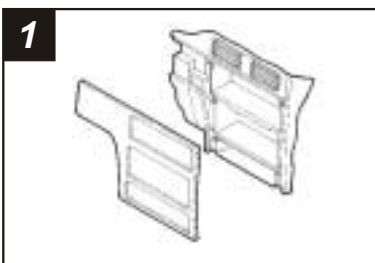

1 Disconnect the negative battery terminal to prevent an accidental short circuit. Remove the ashtray by pressing down on the inner spring (for Concorde models only). Unclip the gear shifter trim bezel and slide the bezel toward the rear of the vehicle. Unclip the dash trim bezel and disconnect the wiring. Remove (4) Phillips screws securing the factory head unit and disconnect the wiring. *Skip to the Installation Instructions for ALL VEHICLES on Page #3.*

CHRYSLER PT Cruiser 2001-03

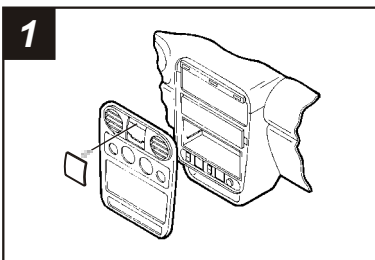

1 Disconnect the negative battery terminal to prevent an accidental short circuit. Unclip the power window control panel and remove (1) Phillips screw exposed. Pull off the climate control knobs. Unclip the dash trim bezel and remove. Remove (4) Phillips screws securing the factory head unit and disconnect the wiring. *Skip to the Installation Instructions for ALL VEHICLES on Page #3.*

CHRYSLER Sebring / DODGE Stratus 2001-03

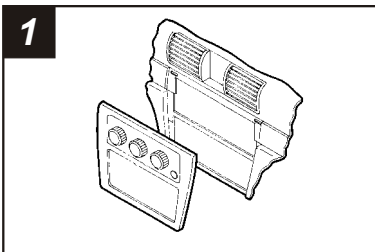

1 Disconnect the negative battery terminal to prevent an accidental short circuit. Unclip the radio trim bezel and remove. (For 2-door models, two Phillips screws must be removed from under the climate controls). Remove (4) Phillips screws securing the factory head unit and disconnect the wiring. *Skip to the Installation Instructions for ALL VEHICLES on Page #3.*

CHRYSLER Town & Country / DODGE Caravan 2001-03

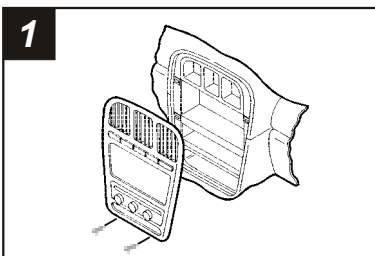

1 Disconnect the negative battery terminal to prevent an accidental short circuit. Remove the cupholder and unclip the trim piece located above the cupholder cavity. Remove (2) Phillips screws from the base of the dash trim bezel. Unclip the dash trim bezel and remove. Remove (4) Phillips screws securing the factory head unit and disconnect the wiring. *Skip to the Installation Instructions for ALL VEHICLES on Page #3.*

DODGE Intrepid 1998-03

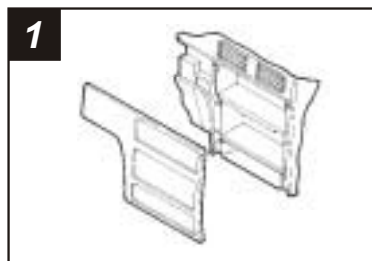

1 Disconnect the negative battery terminal to prevent an accidental short circuit. Unclip the gear shifter trim bezel and slide the bezel toward the rear of the vehicle. Unclip the dash trim bezel and disconnect the wiring. Remove (4) Phillips screws securing the factory head unit and disconnect the wiring. *Skip to the Installation Instructions for ALL VEHICLES on Page #3.*

DODGE / PLYMOUTH Neon 2000-03

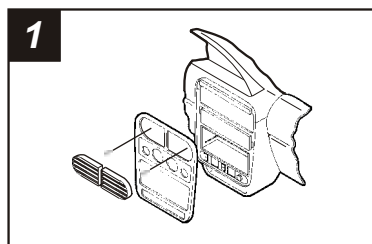

1 Disconnect the negative battery terminal to prevent an accidental short circuit. Remove the climate control knobs. Unclip and remove the a/c vents and remove (1) Phillips screw exposed in each vent cavity. Remove (4) Phillips screws securing the factory head unit and disconnect the wiring. *Skip to the Installation Instructions for ALL VEHICLES on Page #3.*

DODGE Ram 2002-03

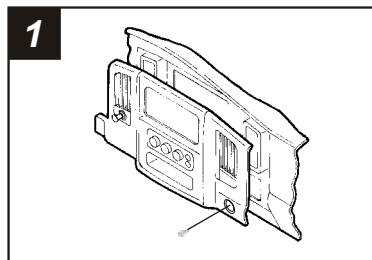

1 Disconnect the negative battery terminal to prevent an accidental short circuit. Unclip the top edge of the knee bolster panel under the steering column (it is NOT necessary to remove the panel). Remove (1) Phillips screw under the right vent. Unclip the dash trim bezel and remove. Remove (4) Phillips screws securing the factory head unit and disconnect the wiring. *Skip to the Installation Instructions for ALL VEHICLES on Page #3.*

JEEP Grand Cherokee 1999-03 / Liberty 2002-03 / Wrangler 2003

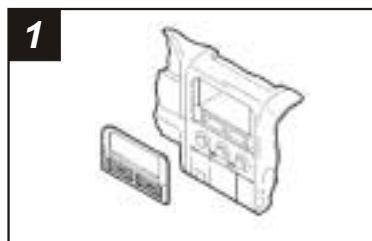

1 Disconnect the negative battery terminal to prevent an accidental short circuit. Unclip the radio trim bezel and remove. Remove (4) Phillips screws securing the factory head unit and disconnect the wiring. *Skip to the Installation Instructions for ALL VEHICLES on Page #3.*

ALL VEHICLES

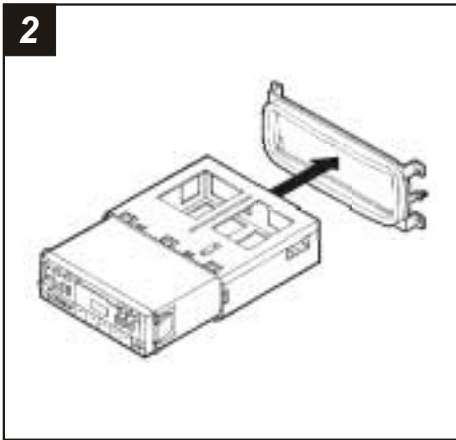

DIN HEAD UNITS: Cut and remove the shaft supports from the **Radio Housing**. Slide the DIN cage into the kit and secure by bending the metal locking tabs down. Slide the aftermarket head unit into the cage until secure.

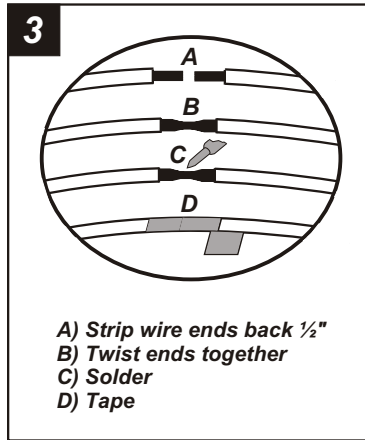

Locate the factory wiring harness in the dash. Metra recommends using the proper mating adaptor and making connections as shown. (Isolate and individually tape off the ends of any unused wires to prevent electrical short circuit).

- A) Strip wire ends back 1/2"
- B) Twist ends together
- C) Solder
- D) Tape

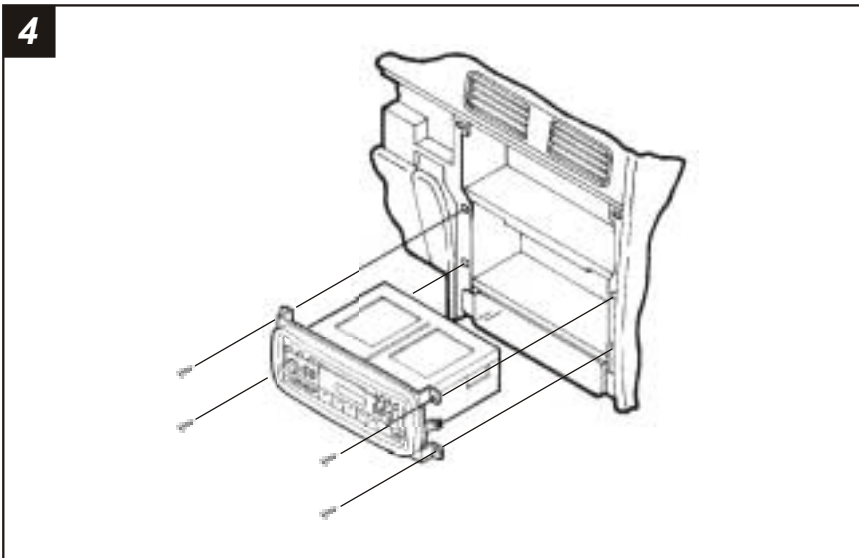

Re-connect the battery terminal and test the unit for proper operation. Mount the head unit/kit assembly to the sub-dash with (4) Phillips screws previously removed in step #1.

KIT FEATURES

- DIN head unit provisions

KIT COMPONENTS

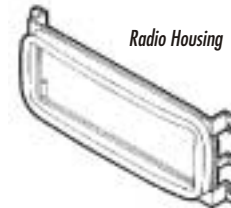

Radio Housing

TOOLS REQUIRED



Phillips screwdriver



99-6503 INSTALLATION INSTRUCTIONS

APPLICATIONS

CAR	PAGE
CHRYSLER	
300M 1999-03.....	1
Concorde 1998-03.....	1
LHS 1998-03.....	1
PT Cruiser 2001-03.....	1
Sebring 2001-03.....	1
Town & Country 2001-03.....	1
DODGE	
Caravan 2001-03.....	1
Dakota 2001-03.....	3
Durango 2001-03.....	3
Intrepid 1998-03.....	2
Neon 2000-03.....	2
Ram 2002-03.....	2
Stratus 2001-03.....	1
JEEP	
Grand Cherokee 1999-03.....	2
Liberty 2002-03.....	2
Wrangler 2003.....	2
PLYMOUTH	
Neon 2000-01.....	2

* Call Metra's Technical Support line for dash disassembly

☎ 1-800-221-0932 🌐 www.metraonline.com

© COPYRIGHT 2001 METRA ELECTRONICS CORPORATION