

2-SHAFT HEAD UNITS: Attach the **Faceplate** to the **Radio Housing**. Slide the aftermarket head unit into the kit and secure with shaft nuts. (see Fig. A)

DIN HEAD UNITS: Cut and remove the shaft supports. Slide the DIN cage into the **Radio Housing** and secure by bending the metal locking tabs down. Slide the aftermarket head unit into the cage until secure. (see Fig. B)

(If an equalizer will be included, slide the unit into the back of the **Radio Housing** and secure. If an equalizer will NOT be included, snap the **Equalizer Dummy Plate** into the opening).

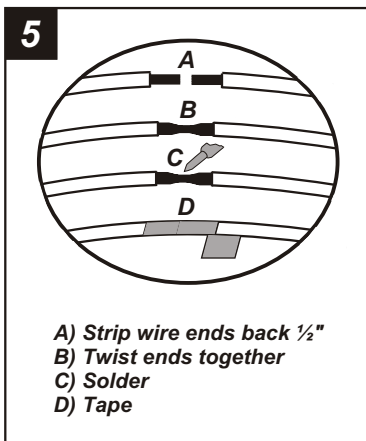

Locate the factory wiring harness in the dash. Metra recommends using the proper mating adaptor and making connections as shown. (Isolate and individually tape off the ends of any unused wires to prevent electrical short circuit).

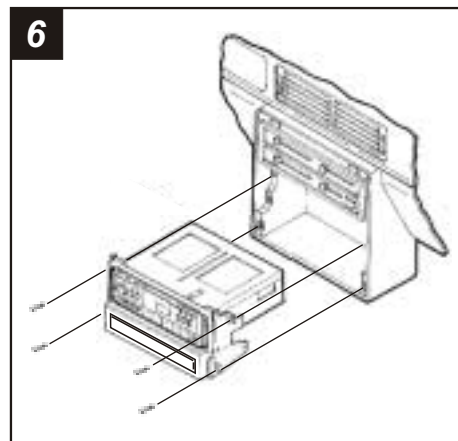

Re-connect the battery terminal and test the unit for proper operation. Mount the head unit/kit assembly to the sub-dash with those screws previously removed.

KIT COMPONENTS

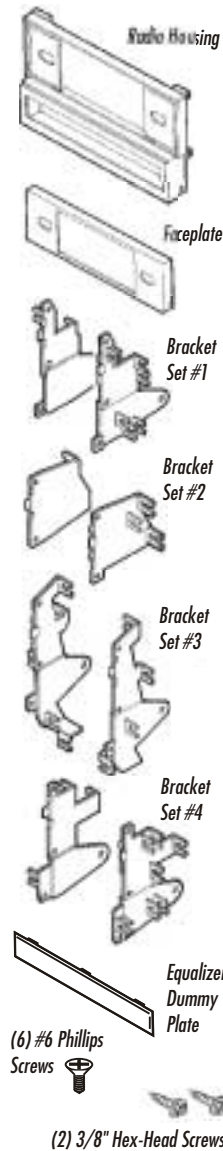

TOOLS REQUIRED



99-8101 AW-952TY DW-8101 INSTALLATION INSTRUCTIONS

APPLICATIONS

CAR	PAGE
TOYOTA	
4Runner 1984-88.....	1
4Runner 1989-95.....	1
4Runner 1996-2002.....	2
Camry 1987-91.....	2
Celica (GT/GTS) 1986-89.....	3
Celica 1990-93.....	3
Corolla (GTS/SR5) 1984-87.....	4
Corolla (sedan/wagon-lower dash) 1988-92.....	4
Corolla (sedan/wagon-upper dash) 1988-92.....	5
Corolla (coupe-lower dash) 1993-97.....	5
Corolla (coupe-upper dash) 1993-97.....	6
MR2 1991-95.....	6
Pickup 1984-88.....	7
Pickup 1989-91.....	7
Pickup 1992-2002.....	8
Supra 1986.5-92.....	8
T100 1993-98.....	9
Tacoma 1995-2002.....	9

TOYOTA 4Runner 1984-88

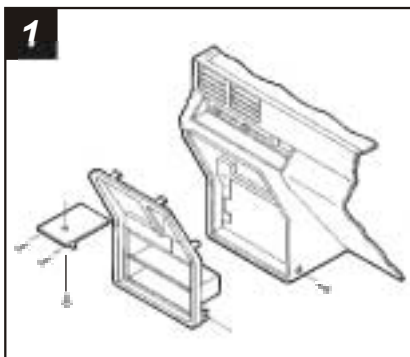

Disconnect the negative battery terminal to prevent an accidental short circuit. Remove the ashtray and (3) screws from the ashtray bracket. Remove (1) screw from each side of the dash console and unsnap the trim bezel.

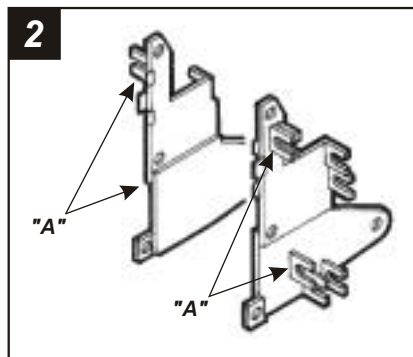

Cut and remove all mounting tabs on **Bracket Set #1** EXCEPT tabs "A". The mounting tabs can be identified by the stamped letter on the back of each tab. Skip to the *Installation Instructions* for ALL VEHICLES on Page #10.

TOYOTA 4Runner 1989-95

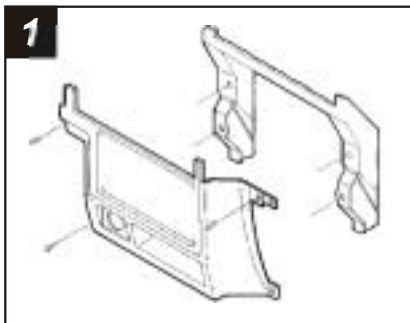

Disconnect the negative battery terminal to prevent an accidental short circuit. Remove the driver's side speaker panel by removing (3) screws and (1) 10mm bolt. Remove (1) screw from the left side of the housing and unsnap the ignition cover. Remove the glove compartment assembly by removing (1) 10mm bolt from the bottom of the speaker panel and (3) screws from the right side of the housing. Remove the remaining (3) screws securing the radio trim bezel.

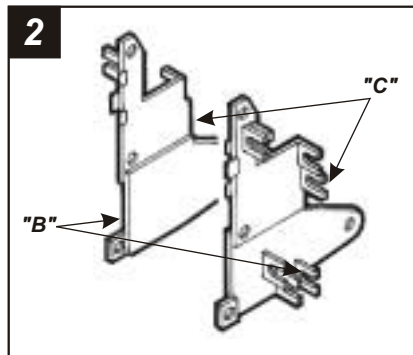

Cut and remove all mounting tabs on **Bracket Set #1** EXCEPT top tabs "C" and bottom tabs "B". The mounting tabs can be identified by the stamped letter on the back of each tab. Skip to the *Installation Instructions* for ALL VEHICLES on Page #10.

ALL VEHICLES

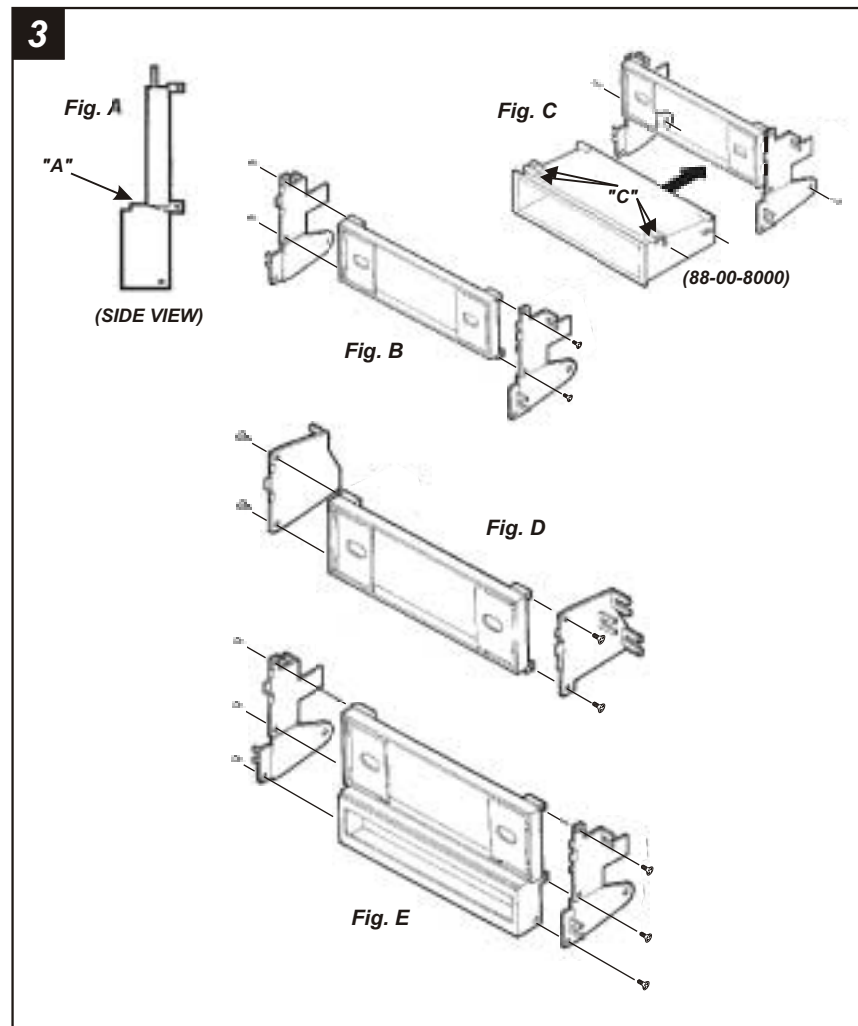

POCKET RETENTION: Cut a diagonal score line on each side of the **Radio Housing** ("A"), break away the bottom portion of the Housing and discard. (see Fig. A) Mount the Brackets to the converted Radio Housing with (4) #6 Phillips Screws. (see Fig. B) Order Metra's 88-00-8000, cut and remove sockets "C" and mount the pocket to the Brackets with (2) 3/8" Hex-Head Screws and (2) locator pins. (see Fig. C)

UPPER DASH COROLLA APPLICATIONS: Cut a diagonal score line on each side of the **Radio Housing**, break away the bottom portion of the Housing and discard. (see Fig. A) Mount the Brackets to the converted Radio Housing with (4) #6 Phillips Screws. (see Fig. D)

ALL OTHER APPLICATIONS: Mount the Brackets to the **Radio Housing** with (6) #6 Phillips Screws. (see Fig. E)

TOYOTA T100 1993-98

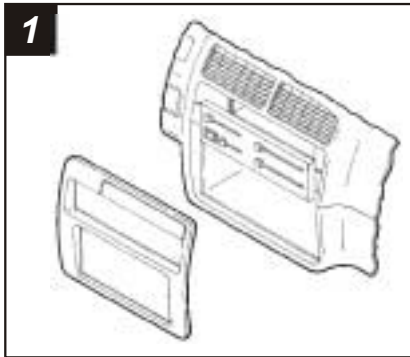

1
Disconnect the negative battery terminal to prevent an accidental short circuit. Pull the cupholder out and unsnap the trim bezel from the dash. Remove (4) screws securing the factory head unit and disconnect the wiring.

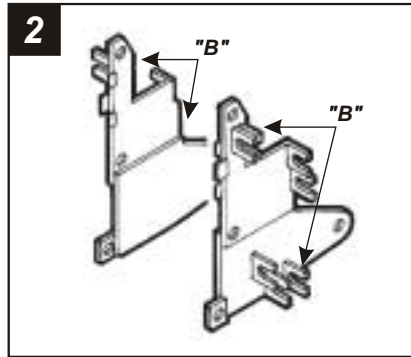

2
Cut and remove all mounting tabs on **Bracket Set #1** EXCEPT tabs "B". The mounting tabs can be identified by the stamped letter on the back of each tab. Skip to the *Installation Instructions for ALL VEHICLES on Page #10*.

TOYOTA 4Runner 1996-2002

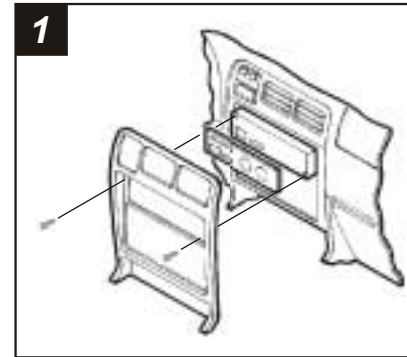

1
Disconnect the negative battery terminal to prevent an accidental short circuit. Open the center armrest door. Unsnap the parking brake trim panel to access the gear shifter trim panel. Unsnap the gear shifter trim panel and remove. Remove the climate control knobs. Remove the climate control trim plate and (2) Phillips screws exposed. Unclip the radio trim bezel and remove. Remove (4) Phillips screws securing the factory head unit and disconnect the wiring.

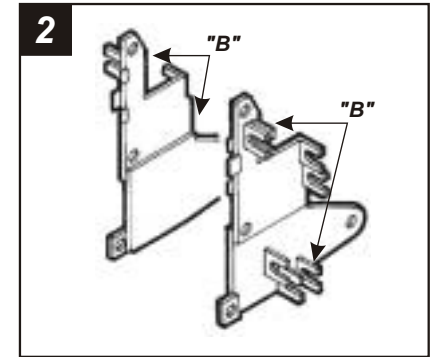

2
Cut and remove all mounting tabs on **Bracket Set #1** EXCEPT tabs "B". The mounting tabs can be identified by the stamped letter on the back of each tab. Skip to the *Installation Instructions for ALL VEHICLES on Page #10*.

TOYOTA Tacoma 1995-2002

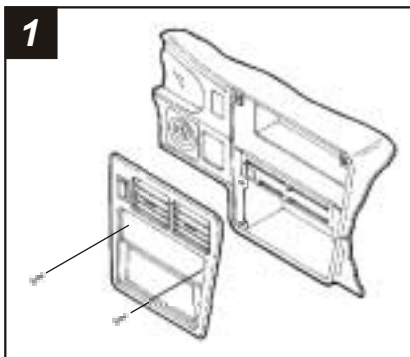

1
Disconnect the negative battery terminal to prevent an accidental short circuit. Remove the climate control knobs. Unsnap the climate control trim panel and remove (2) screws exposed. Gently unclip the dash trim bezel, lift up on the panel and remove.

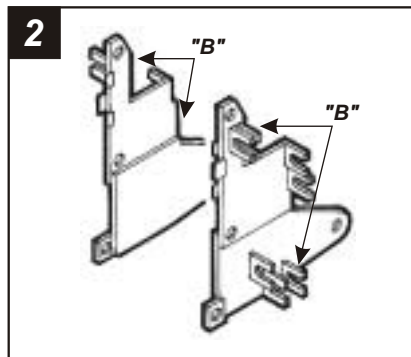

2
Cut and remove all mounting tabs on **Bracket Set #1** EXCEPT top tabs "B". The mounting tabs can be identified by the stamped letter on the back of each tab. Skip to the *Installation Instructions for ALL VEHICLES on Page #10*.

TOYOTA Camry 1987-91

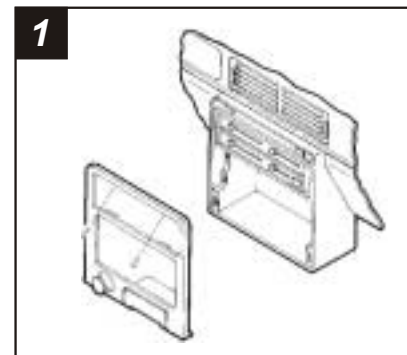

1
Disconnect the negative battery terminal to prevent an accidental short circuit. Remove (2) screws above the climate controls and gently unsnap the dash trim bezel. Remove (4) screws securing the factory head unit and disconnect the wiring.

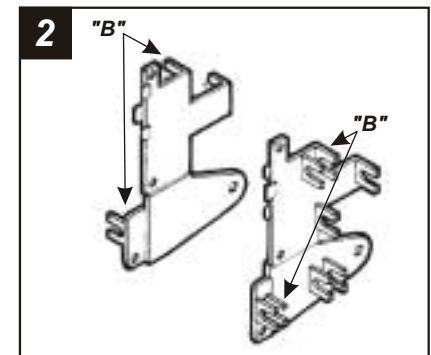

2
Cut and remove all mounting tabs on **Bracket Set #4** EXCEPT tabs "B". The mounting tabs can be identified by the stamped letter on the back of each tab. Skip to the *Installation Instructions for ALL VEHICLES on Page #10*.

TOYOTA Celica (GT/GTS) 1986-89

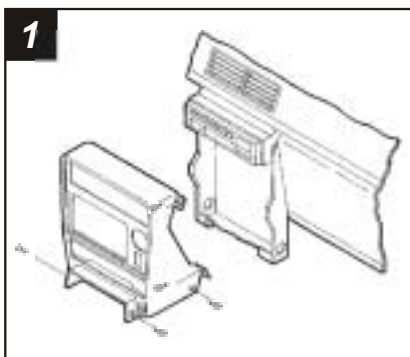

1
Disconnect the negative battery terminal to prevent an accidental short circuit. Remove (2) screws from the lower steering column panel and remove. Remove the (2) screws exposed on the radio trim bezel. Open the glove box and remove (1) screw and (1) bolt exposed. Remove (2) screws from the ashtray cavity and (2) screws from the bracket. Remove (2) screws from each lower side of the trim bezel and unsnap the bezel.

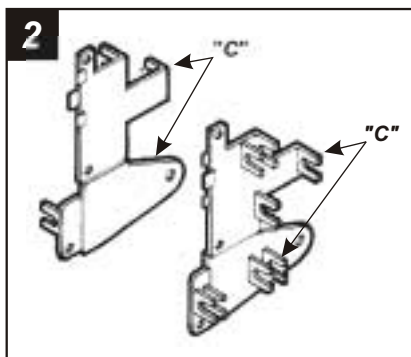

2
Cut and remove all mounting tabs on **Bracket Set #4** EXCEPT tabs "C". The mounting tabs can be identified by the stamped letter on the back of each tab. Skip to the *Installation Instructions for ALL VEHICLES* on Page #10.

TOYOTA Pickup 1992-2002

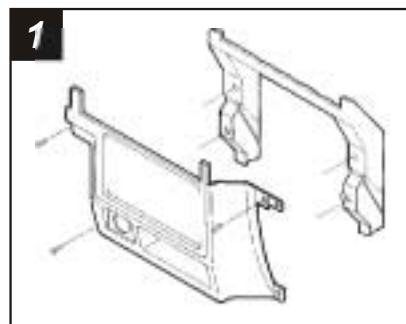

1
Disconnect the negative battery terminal to prevent an accidental short circuit. Remove the driver's side speaker panel by removing (3) screws and (1) 10mm bolt. Remove (1) screw from the left side of the housing and unsnap the ignition cover. Remove the glove compartment assembly by removing (1) 10mm bolt from the bottom of the speaker panel and (3) screws from the right side of the housing. Remove the remaining (3) screws securing the radio trim bezel.

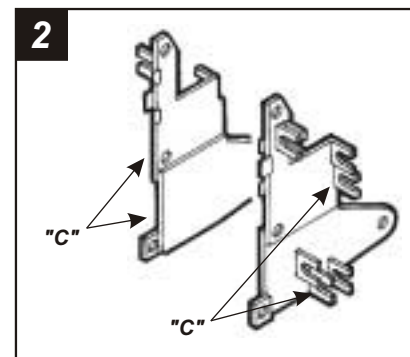

2
Cut and remove all mounting tabs on **Bracket Set #1** EXCEPT tabs "C". The mounting tabs can be identified by the stamped letter on the back of each tab. Skip to the *Installation Instructions for ALL VEHICLES* on Page #10.

TOYOTA Celica 1990-93

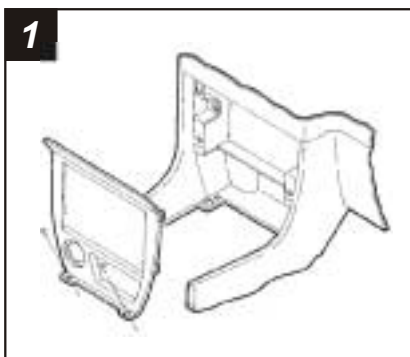

1
Disconnect the negative battery terminal to prevent an accidental short circuit. Carefully pry up on the gear shifter trim panel and remove. Remove (2) screws exposed on the bottom edge of the radio trim panel. Unsnap the panel and disconnect the ashtray and cigarette lighter wiring.

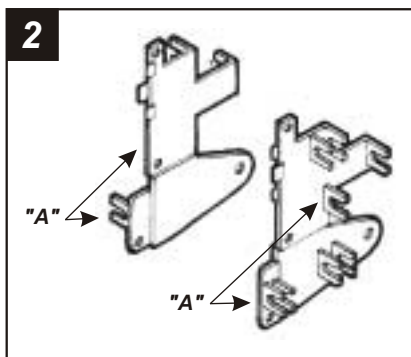

2
Cut and remove all mounting tabs on **Bracket Set #4** EXCEPT tabs "A". The mounting tabs can be identified by the stamped letter on the back of each tab. Skip to the *Installation Instructions for ALL VEHICLES* on Page #10.

TOYOTA Supra 1986.5-92

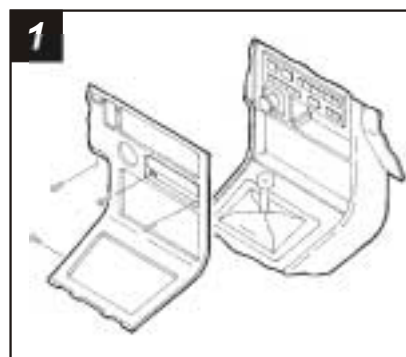

1
Disconnect the negative battery terminal to prevent an accidental short circuit. Remove the ashtray and (2) screws from the ashtray cavity. Remove (1) screw located to the right of the steering column, and (1) screw located to the left of the gear shifter.

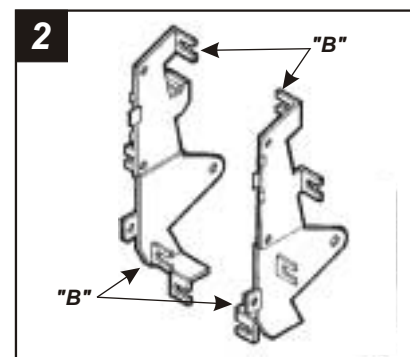

2
Cut and remove all mounting tabs on **Bracket Set #3** EXCEPT tabs "B". The mounting tabs can be identified by the stamped letter on the back of each tab. Skip to the *Installation Instructions for ALL VEHICLES* on Page #10.

TOYOTA Pickup 1984-88

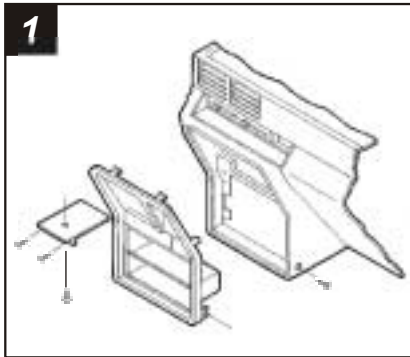

Disconnect the negative battery terminal to prevent an accidental short circuit. Remove the ashtray and (3) screws from the ashtray bracket. Remove (1) screw from each side of the dash console and unsnap the trim bezel.

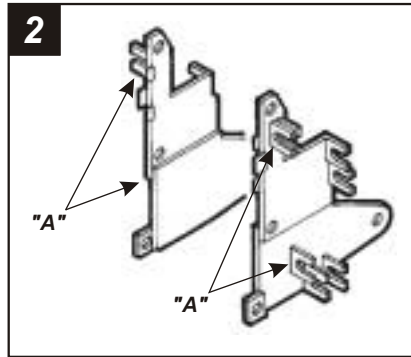

Cut and remove all mounting tabs on **Bracket Set #1** EXCEPT tabs "A". The mounting tabs can be identified by the stamped letter on the back of each tab. Skip to the *Installation Instructions for ALL VEHICLES on Page #10*.

TOYOTA Corolla (GTS/SR5) 1984-87

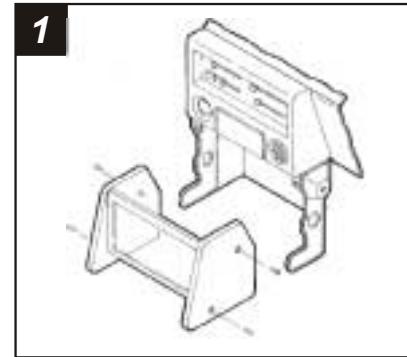

Disconnect the negative battery terminal to prevent an accidental short circuit. Remove (2) Phillips screws from each side of the console trim bezel. Remove (4) screws securing the factory head unit and disconnect the wiring.

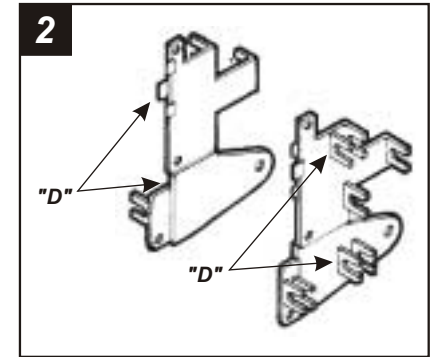

Cut and remove all mounting tabs on **Bracket Set #4** EXCEPT tabs "D". The mounting tabs can be identified by the stamped letter on the back of each tab. Skip to the *Installation Instructions for ALL VEHICLES on Page #10*.

TOYOTA Pickup 1989-91

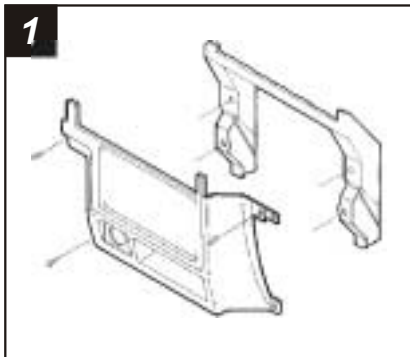

Disconnect the negative battery terminal to prevent an accidental short circuit. Remove the driver's side speaker panel by removing (3) screws and (1) 10mm bolt. Remove (1) screw from the left side of the housing and unsnap the ignition cover. Remove the glove compartment assembly by removing (1) 10mm bolt from the bottom of the speaker panel and (3) screws from the right side of the housing. Remove the remaining (3) screws securing the radio trim bezel.

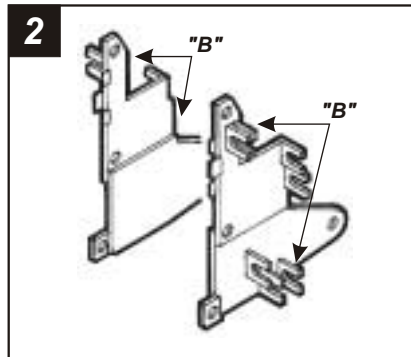

Cut and remove all mounting tabs on **Bracket Set #1** EXCEPT tabs "B". The mounting tabs can be identified by the stamped letter on the back of each tab. Skip to the *Installation Instructions for ALL VEHICLES on Page #10*.

TOYOTA Corolla (sed/wag-lower dash) 1988-92

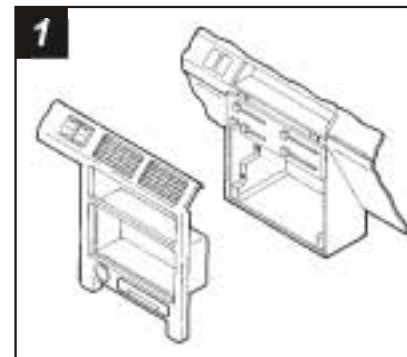

Disconnect the negative battery terminal to prevent an accidental short circuit. Remove (1) screw located to the right of the ignition switch. Remove (1) screw located above the driver's side speaker. Carefully unsnap the dash trim bezel (some force may be required).

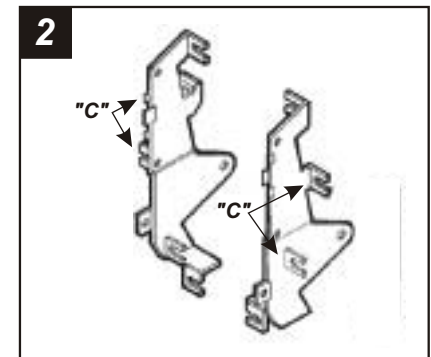

Cut and remove all mounting tabs on **Bracket Set #3** EXCEPT tabs "C". The mounting tabs can be identified by the stamped letter on the back of each tab. Skip to the *Installation Instructions for ALL VEHICLES on Page #10*.

TOYOTA Corolla (sed/wag-upper dash) 1988-92

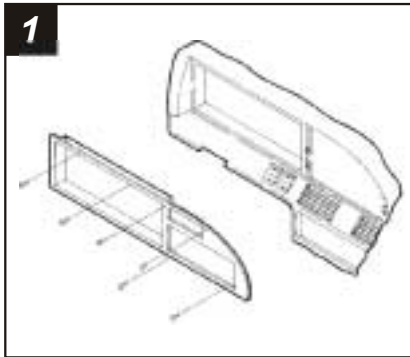

Disconnect the negative battery terminal to prevent an accidental short circuit. Remove (4) screws from the top edge of the instrument trim bezel and (2) screws below the radio opening. Remove (1) screw from the lower-left tab of the bezel (to the right of the a/c vent) and unsnap the bezel.

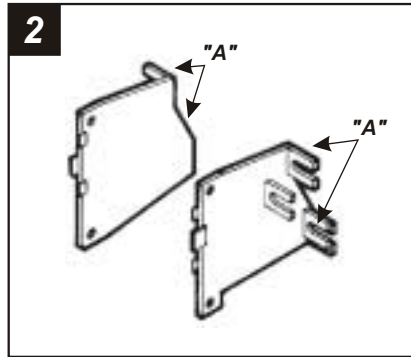

Cut and remove all mounting tabs on **Bracket Set #2** EXCEPT tabs "A". The mounting tabs can be identified by the stamped letter on the back of each tab. Skip to the *Installation Instructions for ALL VEHICLES* on Page #10.

TOYOTA Corolla (coupe-upper dash) 1993-97

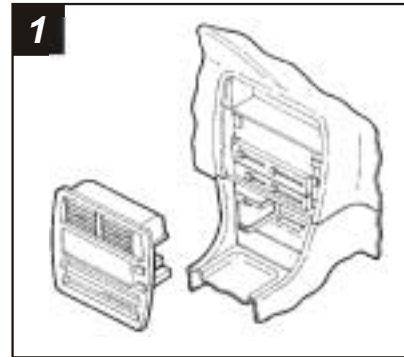

Disconnect the negative battery terminal to prevent an accidental short circuit. Remove the climate control knobs and unsnap the dash trim bezel. Disconnect the clock and hazard leads.

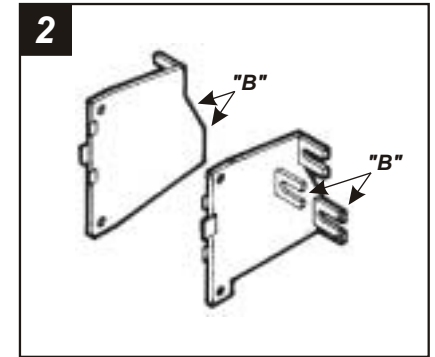

Cut and remove all mounting tabs on **Bracket Set #2** EXCEPT tabs "B". The mounting tabs can be identified by the stamped letter on the back of each tab. Skip to the *Installation Instructions for ALL VEHICLES* on Page #10.

TOYOTA Corolla (coupe-lower dash) 1993-97

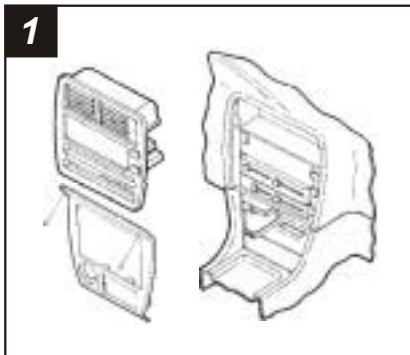

Disconnect the negative battery terminal to prevent an accidental short circuit. Remove the climate control knobs, unsnap the upper trim bezel and disconnect the hazard and clock leads. Remove (2) screws from the lower trim bezel and remove.

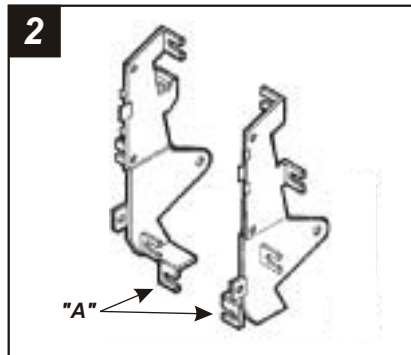

Cut and remove all mounting tabs on **Bracket Set #3** EXCEPT tabs "A". The mounting tabs can be identified by the stamped letter on the back of each tab. Skip to the *Installation Instructions for ALL VEHICLES* on Page #10.

TOYOTA MR2 1991-95

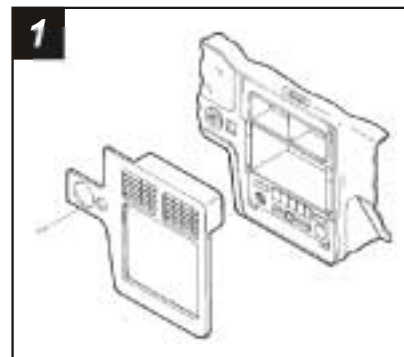

Disconnect the negative battery terminal to prevent an accidental short circuit. Remove the ashtray and (2) screws from the ashtray cavity. Unsnap and remove the shifter console bezel. Remove (1) screw below the ignition switch and remove the dash trim bezel.

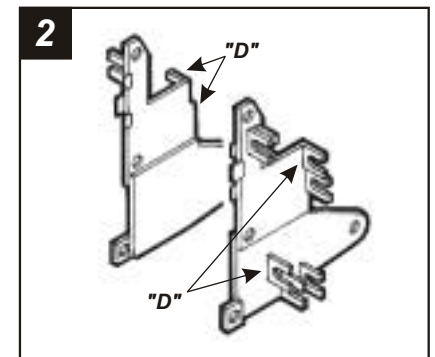

Cut and remove all mounting tabs on **Bracket Set #1** EXCEPT tabs "D". The mounting tabs can be identified by the stamped letter on the back of each tab. Skip to the *Installation Instructions for ALL VEHICLES* on Page #10.